

OptimaGSM – alarm system with GSM communication and building automation.

Installation Guide (DTR).



Ropam Elektronik

Tel. +48 12 272 39 71
Faks +48 12 379 34 10

Polanka 301
32-400 Myślenice, Polska

<https://www.ropam.com.pl/en>
biuro@ropam.com.pl

Document version : 1.0
2017-10-06

WARNINGS

For safety reasons, this equipment should be installed only by qualified personnel.

Before proceeding with the installation, refer to the above instruction, the connection must be performed without the power supply.

Do not power on the unit without connecting an external antenna (starting the device without the antenna connected may damage the phone transmissions and void the warranty!).

Do not interfere with construction or carry out repairs yourself.

Protect your electronics against electrostatic discharges.

In order to meet LVD and EMC requirements, the following must be observed: power, installation, shielding - according to application. The device is a source of electromagnetic waves, so it may interfere with other radio devices in specific configurations.

Ropam Elektronik is not responsible for any malfunction of the GSM network and any possible technical problems.

WEEE LABELING

Waste electrical and electronic equipment must not be disposed of with household waste. According to the WEEE directive (EU Directive 2002/96 / EC), electrical and electronic equipment used should be used separately. In Poland, it is prohibited to place together with other wastes of worn equipment marked with a crossed-out wheeled bin symbol in accordance with the regulations on waste electrical and electronic equipment. The user who intends to dispose of this product is obliged to give the above mentioned to the point of collection of used equipment. Collection points are conducted, among others, by the wholesale and retail sellers of this equipment and the municipal organizational units engaged in waste collection activities. The correct implementation of these obligations is particularly important in the case of hazardous equipment that has a negative impact on the environment and human health.

The power supply unit is compatible with a 12V DC lead acid battery (SLA, VRL). It should not be discarded after use, but must be disposed of in accordance with the applicable regulations.

(European Union Directives 91/157 / EEC and 93/86 / EEC).



Table of Contents

1. General description.....	1
Properties.....	1
Appliance.....	2
Warnings.....	3
Requirements for SMS and RopamDroid, DTMF control.....	3
2. System description.....	4
Description of the device.....	4
Device versions.....	4
Description of connectors and elements.....	5
Optical signaling of the state.....	7
Additional modules and extensions.....	9
AP-IP.....	10
General description.....	10
Properties.....	10
Warnings.....	11
Description of the module.....	11
Construction and description.....	11
Assembly and installation.....	13
Basic requirements.....	13
Connection and start-up of the AP-IP module.....	13
Configuration.....	15
Configuration: OptimaGSM Manager.....	16
Configuration and status control: SMS.....	18
System configuration: TCP / IP AP-IP module.....	19
Advanced configuration of the router.....	21
Providing a fixed IP address.....	22
System maintenance.....	24
Technical parameters.....	24
Version history.....	25
EXP-I8-RN.....	25
General description.....	25
Properties.....	25
Destiny.....	26

Warnings.....	26
Description of the module	26
Module versions.....	26
Construction and description.....	26
Optical signaling of the state.....	27
Requirements, installation.....	27
Basic requirements.....	27
Installation and connection of the module.....	28
Technical parameters.....	29
Version history.....	29
EXP-O8T-RN.....	30
General description.....	30
Properties.....	30
Destiny.....	30
Warnings.....	30
Description of the module.....	30
Module versions.....	30
Construction and description.....	31
Optical signaling of the state.....	32
Requirements, installation.....	32
Basic requirements.....	32
Installation and connection of the module.....	32
System maintenance.....	33
Technical parameters.....	33
Version history.....	33
EXP-O8R-RN	34
General description.....	34
Properties.....	34
Destiny.....	34
Warnings.....	34
Description of the module	34
Module versions.....	34
Construction and description.....	35
Optical signaling of the state.....	36
Requirements, installation.....	36

Basic requirements.	36
Installation and connection of the module.....	36
System maintenance.	37
Technical parameters.	37
Version history.	38
APm-AERO	38
General description.....	38
Properties.....	38
Destiny.	38
Warnings.	39
Controller description.....	39
Controller versions.	39
Construction and description.	39
Assembly and installation.	39
Basic requirements.	39
Installing the controller.	40
Configuration.	40
Configuration: Partner GSM / OptimaGSM Manager.	40
OptimaGSM Manager: AP-Aero	40
Technical parameters.	44
Version history.	45
Keyfob-AERO	45
General description.....	45
Properties.....	45
Destiny.	45
Warnings.	45
Pilot description.	46
Remote control versions.	46
Construction and description.	46
Requirements, installation.	47
Basic requirements.	47
Installing the controller.	47
Configuration.	47
Preparing the system for work.	47
Configuration: Partner GSM / OptimaGSM Manager._6	49

OptimaGSM Manager: AP-Aero	49
Flags for the pilot in Logic Processor.	51
Technical parameters.	52
Version history.	52
IO-AERO	52
General description.....	52
Properties.....	52
Destiny.	53
Warnings.	53
Description of the module.....	53
Versions of the IO-Aero module.....	53
Construction and description.	54
Assembly and installation.	54
Basic requirements.	54
Description and operation of the IO-Aero module.	55
Installation and programming of the IO module.	55
Reset procedure for lips factory.	56
Configuration.	56
Configuration: Partner GSM / OptimaGSM Manager.	56
OptimaGSM Manager: AP-Aero	56
System maintenance.	58
Technical parameters.	59
Version history.	59
TPR-4	59
General description.....	59
Properties.....	59
Destiny	60
Warnings	60
Description of the touch panel.	60
Construction of the TPR-4 touch panel.....	61
Description of connectors and elements.	61
View and dimensioning of the panel.....	62
Installation and commissioning.....	62
Basic requirements.	62
System cabling.....	63
Panel connection.....	64

Installation and start-up procedure TPR-4	64
Configuration of TPR-4 touch panels.	65
TPR-4 configuration: user menu	66
Set the clock	66
Relay time	66
Turn on Gong.....	67
Reading an SMS.....	67
Brightness of the screensaver	67
Service access.....	67
Thermostats.....	67
Room thermostats	68
Timers 1-4.....	72
USSD codes, test SMS.....	74
Entering the USSD code	74
Send the USSD code to the GSM network	74
Send a test SMS	74
Internet module.....	74
Show network status	75
SSID:.....	75
WPA:.....	75
Module restart	75
Remote programming.....	75
TPR-4 configuration: service menu.....	76
Settings 1.....	77
TPR-4 configuration: OptimaGSM Manager.....	77
Tab: touch panel / settings.	79
Tab: touch panel / display options.	80
Tab: Editing screens.	81
Icon descriptions and functions	82
Firmware update.....	86
TPR-4 software update procedure	87
TPR-4 panel maintenance	87
Technical parameters. TPR-4.....	88
Version history.	89
RHT-AERO.....	89
General description.....	89
Properties	89
Destiny	89
Warnings	89

Description of the module.....	90
Module versions.....	90
Construction and description.....	90
Assembly and installation.....	91
Basic requirements.....	91
Description and operation of the RHT-Aero module.....	91
Installation and programming of the RHT-Aero module. 8.....	91
RHT-Aero flags in Logic Processor.....	92
Configuration.....	93
Preparing the system for work.....	93
Power connection / ext. sensor for the module.....	93
Configuration: OptimaGSM Manager.....	93
OptimaGSM Manager: APx-Aero - temperature / humidity detectors. 5.....	94
Value display settings on the TPR-4 panel. 5.....	94
System maintenance.....	95
Technical parameters.....	95
Version history.....	96
VAR-1U.....	96
General description.....	96
Properties.....	96
Destiny.....	96
Warnings.....	96
Description of the module.....	97
Construction and description.....	97
Module versions.....	98
Requirements, installation.....	98
Basic requirements.....	98
Installation.....	98
Preparing the system for work.....	98
Connecting the module to the control panel.....	99
List of devices cooperating with the module.....	99
Connection of the entry phone to VAR-1U.....	100
Configuration.....	100
OptimaGSM Manager: VAR-1U.....	100
Changing the parameters of the module.....	101
Custom settings.....	102

Downloading a photo from the video door phone.....	102
Bolt control using DTMF.....	103
Switching bolt.....	104
SMS command for control of bolt.....	104
System maintenance.....	104
Technical parameters.....	104
Version history.....	105
3. Installation and commissioning.....	106
Basic requirements.....	106
Wiring the system.....	106
Connection of the RopamNET bus.....	107
Connecting devices to inputs.....	109
Connecting devices to the outputs.....	110
Connecting the signal to the AI input.....	113
Connection of temperature sensors.....	113
Connection of a speech synthesizer, audio module.....	113
Connecting the IQPLC system.....	114
Connection of the AP-IP communication module.....	115
Connecting the power supply to control panel.....	117
Installation and start-up procedure.....	117
The procedure for a reset to factory settings.....	119
4. System configuration.....	120
System configuration: OptimaGSM Manager.....	120
Description of the program toolbar.....	120
Local configuration via COM port.....	120
Remote configuration: TCP / IP (GPRS).....	121
System configuration: TCP / IP AP-IP module.....	122
Firmware upgrade.....	123
Functional description.....	123
Tab: SIM card settings.....	123
Tab: Zones, phone numbers, e-mail address.....	124
Tab: Modules, TPR panels.....	124
Touchpad.....	124
EXP-I8 expander.....	125
APx-Aero.....	125
PSR-ECO-xx.....	127

Hub-IQPLC-D4M.....	127
FGR-4 MMS.....	131
RF-4.....	132
EXP-I8-RN.....	133
EXP-O8x-RN (EXP-O8R-RN or EXP-O8T-RN).....	133
AP-IP.....	134
Tab: Inputs.....	134
Tab: Inputs - notification.....	136
Tab: Inputs - options.....	136
Tab: Outputs.....	137
Tab: Outputs - notifications.....	139
Tab: LogicProcessor.....	139
Logic functions.....	141
Time relays.....	152
Starting values.....	156
Preview of the script.....	158
Simulator.....	158
Application notes.....	159
Tab: Timers.....	159
Tab: Communication, tests, counters.....	159
Tab: System options.....	160
Tab: Analog input.....	161
Tab: Temperature.....	162
Tab: Room thermostats.....	163
Tab: online.....	163
Netmonitor GSM (BTS).....	165
Tab: events.....	167
5. System operation.....	168
Basic SMS commands.....	168
Basic DTMF commands.....	170
RopamDroid application.....	171
RopamOptima application.....	171
Launching.....	172
Configuration.....	173
System demo.....	175

6. SMTP settings for GPRS and IP.	177
Sample e-mail accounts.....	177
Set up an e-mail account, OptimaGSM Manager.	178
Prioritizing sending messages.	179
Email notifications about events.	179
Errors - sending an e-mail.....	181
7. System maintenance.....	183
8. Technical parameters.....	184
9. Version history.....	186
10. Information.....	189

1. General description.

Thank you for choosing Ropam Elektronik products and solutions. We hope that our equipment will meet your requirements and will serve you reliably for years to come. Ropam Elektronik continues to innovate its products and solutions. With the update function products can be enriched with new features and keep up with the modern requirements for the protection of property systems and home automation. We invite you to visit our website www.ropam.com.pl for information on current versions. If you have any additional questions, please contact us by phone or email.

Properties.

The OptimaGSM alarm control panel with peripheral devices is a solution that integrates the electronic burglary signaling system and building automation using the SmartPLC technology. Built-in GSM communicator allows to remote monitoring and controlling of the system. Thanks to the modular design, the system can be expanded and adapted to changing needs of the user.

The control panel has unique functions compared to competing products and is the most functional system on the market in its class, including:

- building automation functions using communication on the electric network, unique SmartPLC technology,
- the ability to control using the RopamDroid application for Android smartphones,
- flexible control of the armed mode: touch panels, SMS, system input, radio remote controls (RF-4), in accordance with the requirements of current installations: 'from the shell to the residence',
- support of touch panels; surface-mounted version TRP-1-O, TPR-2W-O, TPR-2B-O and concealed TPR-1F-O, TPR-4W, TPR-4B
- visual verification of the object's status: FGR-4 module for sending MMS / E-MAIL messages with photos from industrial cameras,
- VSR-2 speech synthesizer, allowing you to send 16 voice messages containing unique information about the event (VOICE) or VSR-1, allowing you to send a voice message (VOICE),
- AMR-1 audio module (microphone), allowing for eavesdropping of the object and audio verification,
- VAR-1 gateway and FGR-4 module for integration with a video intercom, integration allows for a telephone conversation between a door station and a mobile phone as well as sending pictures in the MMS format,
- integration of audio intercoms and intercoms,
- temperature sensors for controlling and recording temperature and thermostat function,
- RF-4 radio controller for controlling the armed mode and outputs (4) through radio remote controls,
- PSR-ECO power supply system for large systems and in case of working in variable temperatures in order to properly service the battery,
- analog input AI 0-10V for checking physical parameters, eg battery voltage, humidity [% RH], temperature, etc.



SmartPLC technology integrates the OptimaGSM system with distributed "smart connectors". Communication between the control panel and the concentrator is based on the RopamNET bus. SmartPLC while the communication between the concentrator and intelligent connector is carried out after the power supply lines of low-voltage buildings installations. SmartPLC is a unique and innovative approach to communication, transforming electrical installations of building into a communication bus for control and monitoring. SmartPLC technology from Ropam Elektronik opens a new chapter in building automation and gives so far unavailable options for designers and integrators.

Appliance.

The alarm system built on the basis of the OptimaGSM series alarm panels, TPR-xx touch panels and other additional devices is an ideal solution for residential buildings and small commercial facilities. Modern design, proven technology of the touch panel with a spectacular color LCD display is ideal for composing in most interiors and rooms. The intuitive and clear interface makes the control of the alarm system has never been as easy as with TPR-xx. The touch panel in combination with the control panel allows you to build a fully functional alarm system.

The OptimaGSM system also allows you to create simple home automation applications with remote control via SMS / CLIP and Wifi / Ethernet.

Flexible functions also allow use in systems that use binary signal control, temperature, visual verification is required and information transfer is based on SMS, VOICE, MMS, e-mail.

- building automation systems integrated with the OptimaGSM system,
- smart home, home automation,
- electronic intrusion detection systems,
- Remote control and monitoring of electrical equipment,
- intelligent lighting,

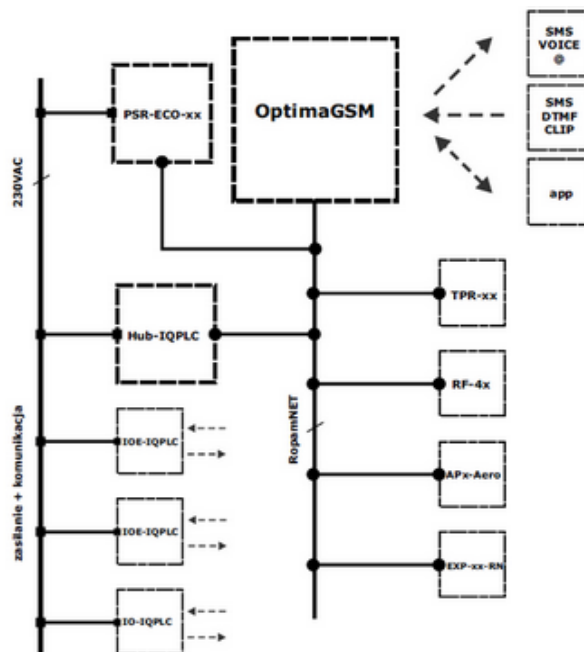

Warnings.

Ropam Elektronik devices are part of a full alarm system, whose working effectiveness depends on the quality and technical condition of all devices (detectors, signaling devices), cabling, etc. included in the system. The user is obliged to periodically test the operation of the alarm system. It is necessary to check whether the control panel reacts to the violation of individual detectors (PIR, reed switches, etc.) or signaling devices (external and internal) and notifications. The detailed method of system control is determined by the installer that the system has designed. Periodic system maintenance is recommended (with device status check, back-up power supply, system operation, messaging, etc.).

Ropam Elektronik is not responsible for the correct operation of operators and GSM network infrastructure used for alarm and remote control messages. It is advisable to use a GSM operator that guarantees min. Two BTSs of the given system location with GSM communication. In addition, we recommend using such services and subscriptions available on the market that guarantee correct operation (human factor minimization, eg blocked outgoing calls due to lack of funds in the account, allow for full configuration of the GSM track (for example, disable advertising services).

We do not recommend using national roaming operators!

In addition, it should be noted that the **services guaranteed by GSM operators are voice services (VOICE)** rather than SMS, so important information should be transmitted via voice calls and the exact identification of the event takes place in the SMS (eg VOICE + SMS, CLIP + SMS).

For service like **e-mail transmission** it is recommended to create a independent e-mail account (eg. Alarm@domena.pl) in a proven provider e-mail accounts. Sharing of data to an SMTP server from a private account can result in unauthorized access to these accounts.

Requirements for SMS and RopamDroid, DTMF control.

To service via SMS and RopamDroid mobile phone, the smartphone must encode SMS: GSM or UNICODE alphabet, other formats are not supported!

For the RopamDroid application, the smartphone must have compatible SMS support with the Android API and not have overlays, other SMS interception apps that have priority for the inbox or outbox.

For proper setup and operation of RopamBasic it is required to have adequate knowledge of system configuration and data (service):

- knowledge of the phone number of the SIM card installed in the system,
- knowledge of "SMS password / application login password" and active option: "Possible remote programming via GPRS",
- knowledge of the encryption key TCP / IP.
- control via the RopamBasic requires the setting triggered by the "Mobile Application" for the output,
- for controlling the GSM thermostat, it is necessary to start the function of temperature measurement and thermostat.

To control the DTMF phone, the smartphone must be able to generate DTMF tones during a phone call.

A single DTMF code (pressing the sign) should last for a minimum of 0.5s.

2. System description.

Description of the device.

Device versions.

Code	Description
OptimaGSM	Alarm control panel with GSM communication and building automation functions: SMS / VOICE / CLIP / GPRS / MMS / E-MAIL, 12VDC *, PSR-ECO x1, TELx8, Blx8-48, BOx8-32, AI, TEMPx4, Aero x16, IQPLC x8, PCB, GPRS monitoring, ThermostatGSM, KeyGSM, LoggerTemp. LogicProcessor. (* to power required supervised, intelligent, system power supply: PSR-ECO-5012-RS)
OptimaGSM-D9M	Alarm control panel with GSM communication and building automation functions: SMS / VOICE / CLIP / GPRS / MMS / E-MAIL, 12VDC *, PSR-ECO x1, TELx8, Blx8-48, BOx8-32, AI, TEMPx4, Aero x16, IQPLC x8, housing DIN 9M GPRS monitoring, ThermostatGSM, KeyGSM, LoggerTemp. LogicProcessor. (* to power required supervised, intelligent, system power supply: PSR-ECO-5012-RS)
OptimaGSM-PS	Alarm control panel with GSM communication and building automation functions: SMS / VOICE / CLIP / GPRS / MMS / E-MAIL, 17VAC / 24VDC, buffer power supply 12V / 2A, TELx8, Blx8-48, BOx8-32, AI, TEMPx4, Aero x16, IQPLC x8, PCB GPRS monitoring, ThermostatGSM, KeyGSM, LoggerTemp. LogicProcessor
OptimaGSM-PS-D9M	Alarm control panel with GSM communication and building automation functions: SMS / VOICE / CLIP / GPRS / MMS / E-MAIL, 17VAC / 24VDC, power supply buf. 12V / 2A, TELx8, Blx8-48, BOx8-32, AI, TEMPx4, Aero x16, IQPLC x8, DIN 9M housing GPRS monitoring, ThermostatGSM, KeyGSM, LoggerTemp. LogicProcessor

Description of connectors and elements.

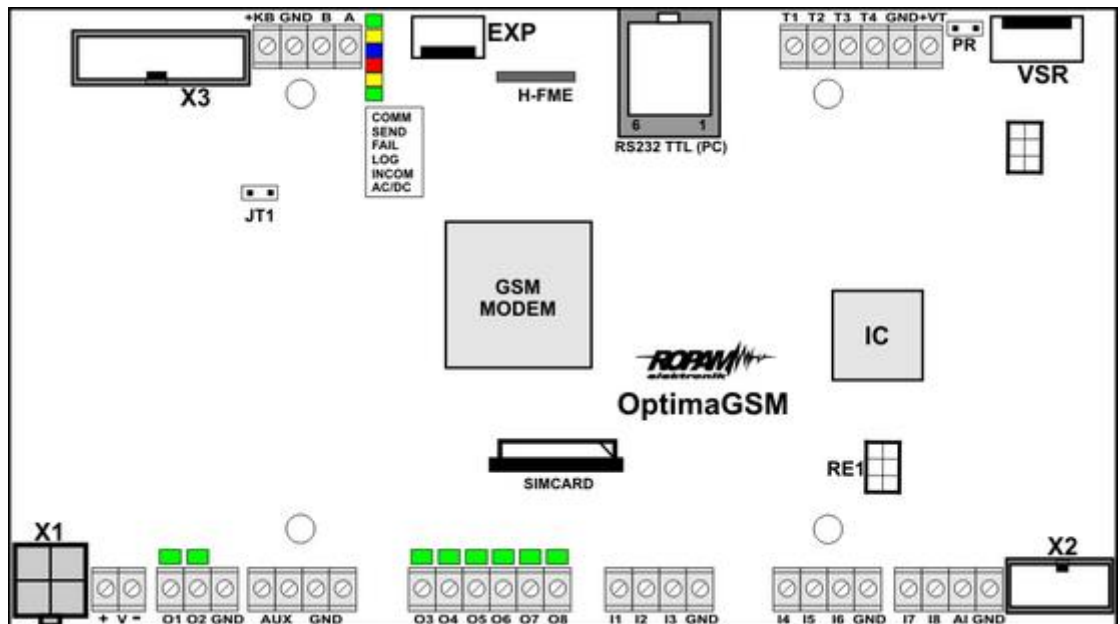
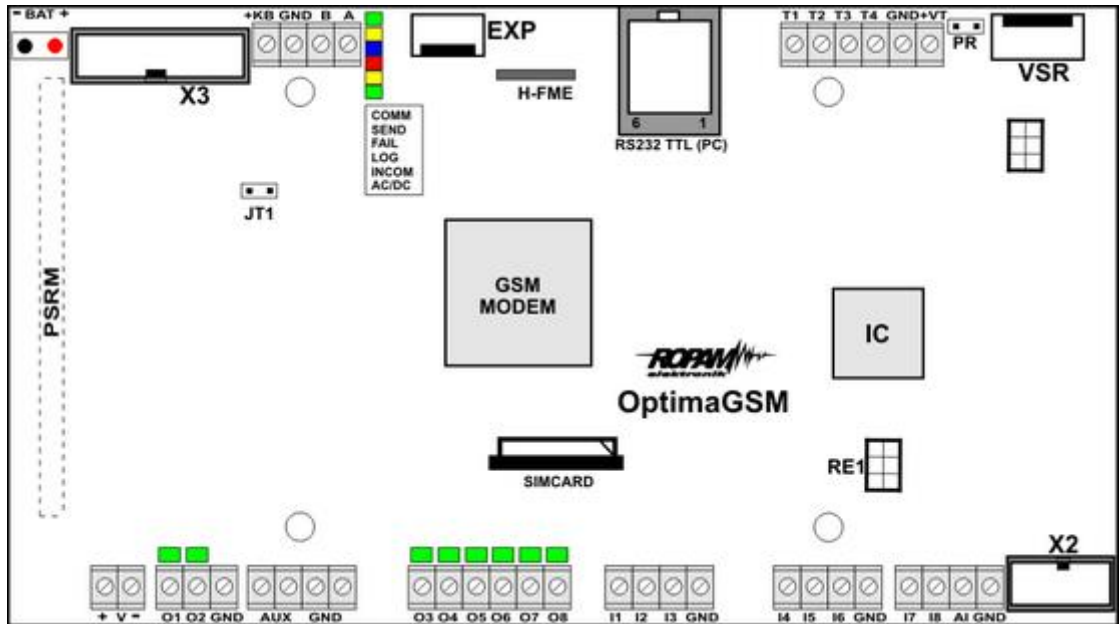

View: OptimaGSM PCB.

Connector / element	Description / Function
+ V -	power terminals OptimaGSM = 9÷14V/DC OptimaGSM-PS = 16÷20V/AC or 20÷30V/DC *
X1	connector for connecting the PSR-ECO-5012-RS power supply; power supply and RopamNET (only OptimaGSM)
O1÷O2	controlled transistor outputs, high-current 12V / 1A, second load terminal: GND, (control of the continuity of the circuit, connection of the signaling device)
O3÷O8	controlled transistor outputs, OpenCollector (OC, GND / 0.1A) second load terminal: AUX (+ 12V)
I1÷I8	control panel inputs, programmed configuration: NO, NC, EOL, DEOL / NC, DEOL / NO, second GND input terminal
AI	analog control panel input, 0-10V, software scaling to any physical value (eg temp = ° C, RH =%)
GND (x8)	the "ground" terminal of the control panel, common for power supply, bus and inputs
AUX (x2)	power output for 12V / DC devices (12VDC / 1A) eg motion detectors, second GND power terminal
O3÷O8	controlled outputs OpenCollector (OC, GND / 0,1A) second terminal load AUX / + KB (+ 12V)
+KB	power output for 12V / DC devices, dedicated to power touch panels (12VDC / 1A)
A B	RopamNET system bus connector (EIA-485), connection principle A-A, B-B, GND-GND
DO1÷DO8	LED diodes indicating the status of O1 ÷ O8 outputs
JT1	jumper for terminating the RopamNET bus (EIA 485) jumper on = terminating resistor on (120 Ohm) jumper removed = terminating terminating resistor (HiZ)
PR	jumper for running software updates via RS232TTL
SIMCARD	connector (slot) for mounting the SIM card (vertical)
+ BAT -	12V battery connection connector (emergency power supply): + BAT (red) = '+' battery - BAT (black) = '-' battery (only OptimaGSM-PS)
X3	connector for connecting the LCD panel (local display),
MODEM GSM	modem, industrial phone GSM / DCS / EGSM

H-FME	antenna connector in the holder, FME-M output, for connecting the GSM antenna
RS232TTL	RJ12 socket for connecting a service computer, used for programming local or firmware updates (RS232-MGSM or USB-MGSM cable required)
VSR	connector for connecting: VSR-2, VSR-1 voice synthesizer or AMR-1 audio module or VAR-1 gateway
EXP	communication interface for additional (local) modules FGR-4 - video processing module for MMS
T1-T4 GND +VT	connector for connecting temperature sensors of the TSR-1-xx series (T1-T4 connector addresses the number of the sensor / thermostat in the system), the supply of temperature sensors must be connected to the connectors: + VT-GND
X2	connector for connecting the EXP-I8 zone expander (local)
COMM	GREEN LED indicates communication with the GSM modem
SEND	YELLOW LED signaling SMS sending or voice connection (in communication mode with computer)
LOG	BLUE LED indicates the GSM network level
FAIL	The RED LED indicates a fault (exchange of firmware in programming mode)
INCOM	YELLOW LED indicates reception of a call or text message
AC/DC	GREEN LED indicates the primary and emergency power supply

Optical signaling of the state.

The control panel is equipped with optical signaling of states. There are LEDs on the PCD board that determine the operating status: messaging, communication with the PC, software version upgrade.

LED	COLOR	SIGNALING STATE NORMAL	SIGNALING THE PROGRAMMING STATE
COMM	GREEN	<ul style="list-style-type: none"> short flashes every 1s = correct communication with the GSM modem 	<ul style="list-style-type: none"> alternating blinking (wave); COMM-SEND-LOG-FAIL = change of firmware in the control panel (active communication)
SEND	Yellow	<ul style="list-style-type: none"> sending SMS and voice notification, notification action is carried out in accordance with the scheme: NOTIFICATION by SMS -1 flash = sending SMS to NUMBER 1, ... 8 flashes = sending SMS to NUMBER 8, 	<ul style="list-style-type: none"> it blinks every 1s. = connection to a service computer blinking alternately SEND and INCOM = restoring copies of settings from

		VOICE NOTIFICATION - 1 flash = connection to NUMBER 1, ... 8 flashes = connection to NUMBER 8,	EEPROM (configuration error checksum) <ul style="list-style-type: none"> alternating blinking (wave); COMM-SEND-LOG-FAIL = change of firmware in the control panel (active communication)
LOG	BLUE	<ul style="list-style-type: none"> a series of short flashes from 1 to 5 every approx. 2s = GSM network level status (1-min 5-max) no flashing = phone not logged in to the GSM network 	<ul style="list-style-type: none"> alternating blinking (wave); COMM-SEND-LOG-FAIL = change of firmware in the control panel (active communication)
FAIL	RED	<ul style="list-style-type: none"> status of the failure, the failure code is synonymous with the number of blinks FAIL diodes on the control panel board (series): 01 - low level network below 2 "dashes" (RSSI <15) 02 - modem not logged in to the GSM network 03 - unsuccessful sending of SMSes in the series 04 - no connection to the GPRS monitoring station (ARC) 05 - no GPRS 06 - no communication with the GSM modem 07 - PIN code error (PUK lock) 08 - SIM error, no SIM 09 - required PIN card not logged in 10 - GSM jamming (jamming) 11 - no AC 12 - overload / short circuit of O1 output 13 - O2 overload / short circuit 14 - no load on the O1 output 15 - no load of the O2 output 16 - overloading / shorting of the AUX output 17 - overload / shorting of the output + KB 18 - low DC power supply voltage (<11V) 19 - failure / lack of battery (<11V) 20 - EEPROM memory error 21 - overload / short circuit of the + VT output 22 - modem power failure 23 - FLASH memory error (serial) 24 - RTC clock chip error 25 - failure of the motherboard inputs 26 - internal error of the MCU microcontroller 27 - blocking SMS / CALL / MMS / E-MAIL, exceeding 24h counter 	<ul style="list-style-type: none"> alternating blinking (wave); COMM-SEND-LOG-FAIL = change of firmware in the control panel (active communication) blinking simultaneously with the INCOM LED every approx. 1s - service mode

		28 - loss of connection with the IQPLC device	
INCOM	YELLOW	<ul style="list-style-type: none"> no light = no incoming calls to the control panel number shines = incoming call, CSD or SMS to the control panel number 	<ul style="list-style-type: none"> shines = CSD modem connection to a remote computer blinking alternately SEND and INCOM = restoring copies of settings from EEPROM (configuration error checksum) blinking simultaneously with the FAIL diode every approx. 1s - service mode
AC/DC	GREEN	<ul style="list-style-type: none"> lit = main power present 17V / AC or 24V / DC blinks = lack of basic power supply, battery supply, 	

Additional modules and extensions.

CODE	Max. value in the system	Description
TPR-xx	4**	Touch panel TPR-xx (surface mounted), TPR-1F (concealed) is a modern element of control and monitoring of the alarm system.- TPR-1x touch panel, modern keyboard for system control in TPR-1 and TPR-1F surface-mounted version, made of INOX steel,- TPR-2x touch panel, modern keyboard for system control in a white or graphite surface version, made of ABS plastic,
FGR-4	1	The FGR-4 module is an innovative and universal device for cooperation with alarm control panels. It allows you to process four video signals into images in the 'jpg' format and send them via multimedia messages via MMS / email. The solution is based on standard services of GSM operators and does not require any special devices and software. The universal functions and design of the FGR-4 module makes it possible to use it to control the state of the object, visual verification of alarm events, eg sending a picture from the object after the burglary, fire alarm and unauthorized entry.
TSR-1-xx	4	Digital temperature sensor, with a measuring range of -20 ° C to + 70 ° C or -55 to + 125 ° C.
VSR-2	1*	The module for recording and reproduction of 16 audio messages (8x 16sec + 8x 8sec), additionally allows you to connect the audio module to listen to the object. MGSM 4.0+ allows the aggregation of independent messages from several (5) recordings in case of violation, entry tampering.
VSR-1	1*	Module for recording and playback 20 seconds of voice message.
AMR-1	1*	The audio module allows you to eavesdrop on an object's audio: during an alarm or after making a voice call.

VAR-1	1*	Gate (interface) for integration of the Ropam system with a video intercom. The system integration allows for a telephone conversation between the door station and a mobile phone as well as sending 'GUESTS' photos via MMS.
EXP-I8	1**	Local input expander connected to the mainboard (X2 connector), 8 additional zones in the system, 2EOL / NC operation configuration, 2EOL / NO, EOL, NC, NO, properties and reaction types as the main board input.
EXP-I8-RN-xx	2**	System zone expander on the system bus (-RN RopamNET), 8 additional zones in the system, 2EOL / NC operation configuration, 2EOL / NO, EOL, NC, NO, properties and reaction types as the main board input.
EXP-O8R-RN-D9MG	2	System output expander on the system bus (-RN RopamNET), 8 additional outputs in the system, 8 relays, potential-free contacts (C / NO / NC), 8A / 250V (AC1), housing for DIN rail, 9 DIN modules,
EXP-O8T-RN-xx		System output expander on the system bus (-RN RopamNET), 8 additional outputs in the system, 8 transistor outputs OpenDrain, potential outputs, 0.8A / GND, optional housing for DIN rail, 4 DIN modules,
Hub-IQPLC-D4M	1	SmartPLC system concentrator for IQPLC system, compatible with OptimaGSM system, RopamNET bus, LogicProcessor: logic + states, support for up to 8 IQPLC devices (intelligent and controlled electric connector, ie controlled electric socket / switch), SmartPLC: innovative and unique two-way communication over the NN power line (230VAC), it does not require additional installation beyond the standard electric one, it facilitates design, expansion and modernization in terms of building automation.
PSR-ECO-5012-RS	1	Intelligent, buffer and supervised PSR-ECO power supply, this solution allows real savings in electricity consumption and battery operation for a minimum design period of the manufacturer. A power supply dedicated to extended systems (current balance > 1.5A) and if the control panel (battery) operates in variable temperature.
RF-4-xx	1	System driver, radio, four-channel. In the set with the control panel, RF-4 creates a flexible alarm system controlled by radio remote controls.
* they use one system connector in the system, they can be installed: VSR-2 or VSR-2 + AMR-1 or VAR-1 or VSR-1.		
** in the system if APx-Aero is installed, the maximum number of hardwired zones is 32 (TPR-xx, EXP-I8, EXP-I8-RN).		

AP-IP

General description

Properties.

The OptimaGSM and AP-IP central set is the first control panel in the market with a built-in Web server, designed for the user to control the system. The solution is fully portable, i.e. works on any web browser, it is secure because it is based on a secure SSL connection and does not require installation of any additional software. In addition to the embedded WebServer, AP-IP supports applications for mobile devices for three operating systems: Android, IOS, Windows Mobile. OptimaGSM and AP-IP control panel is a modern and innovative IoT solution (IoT - Internet of Things), that is access to home appliances, automation control via the Internet.

- compatibility: OptimaGSM, transforms the control panel into a modern IoT solution (translated 'Internet of Things'),
- support for up to eight users simultaneously (TCP / IP clients),
- built-in WebServer based on HTML5 for managing and controlling the control panel from the level of the web browser,
- WebServer: operation on any computer, tablet or smartphone with a web browser (HTML5),
- application support for mobile devices: Android, IOS, Windows Mobile,
- wired communication: Ethernet port: 10/100 BaseT, RJ45.
- wireless WLAN communication: Wifi in 802.11 b / g / n, 2.4 GHz standard, with panel antenna,
- advanced operating modes: WLAN - AccesPoint with DHCP server or DHCP client, ETH mode of operation: DHCP client,
- encrypted TCP / IP transmission (SSL),
- encrypted WLAN transmission: WPA2-PSK,
- support for SMTP e-mail server (with SSL / TSL authorization),
- AP-IP is an independent communication channel for TCP / IP monitoring (except GPRS),
- possibility of programming using ETH or WLAN,
- PCB local module mounted on the PCB of the panel.

Warnings.

- For safety reasons, the device should only be installed by qualified installers.
- Before proceeding to the assembly, read the understanding of the above instructions, connection activities should be carried out without the power supply connected.
- Do not interfere with the construction or carry out independent repairs.
- It is necessary to maintain possible antistatic protection measures to protect electronic circuits on PCBs against electrostatic discharge ESD.
- In order to meet the requirements of LVD and EMC, the following rules must be observed: power supply, installation, shielding - according to the application.

Description of the module.

Construction and description



Connector / element	Description / Function
ETH	RJ45 socket, ETHERNET port, 10/100 BaseT,
RS232TTL	4-pin connector for connecting the communication with the OptimaGSM board using a 4-pin / RJ12 cable
Wifi antenna	Wifi panel antenna with 20 cm connector connected to the AP-IP board UFL connector.
2x3pin connectors	connectors, pins for installing the module on the OptimaGSM board

Comments:

All connections and installation should be made while the motherboard power supply is off.

Incorrect installation of the AP-IP module in the motherboard may cause damage to the devices.

AP-IP is supported from: OptimaGSM v1.9, TPR-xx_OptimaGSM v1.3, OptimaGSM Manager 1.6.

LED	Color	Description
WIFI	BLUE	<ul style="list-style-type: none"> shines with continuous light = correct operation as AccesPoint (DHCP server) blinks = correct operation as Client (DHCP client) no lights = Wifi disabled or incorrect data in Wifi settings (eg no / SSID error, no WPA2 password or it is too short (minimum 8 characters)
INTERNET	YELLOW	<ul style="list-style-type: none"> lights up = correct internet connection (ping works) no light = no internet access
FAIL	RED	<ul style="list-style-type: none"> lights up = one of the failures specified in the configuration no light = no failure
COMM	GREEN	<ul style="list-style-type: none"> blinks = correct communication with the control panel through the RJ12 / 4pin cable lit = no communication with the control panel or unconnected cable no light = lost communication with the control panel (+ possibly shines FAIL)
RJ45-Pwr	GREEN	<ul style="list-style-type: none"> lights up = wired LAN (ETH) connector works correctly
RJ45-Tx/Rx	YELLOW	<ul style="list-style-type: none"> no light = no wired LAN communication blinks = signaling of Tx / Rx transmission

Assembly and installation.

Basic requirements.

The system should be installed in closed rooms with normal air humidity (RH = 90% max. Without condensation) and temperature in the range of -10 ° C to + 55 ° C. When choosing a mounting location, the following criteria should be followed:

- access to the Ethernet network, the ability to configure the network (router),
- a permanent public IP or equivalent Dynamic DNS service is required for remote access from the Internet and the possibility of port forwarding on the router,
- WiFi coverage (attenuation of the walls of the room: wood / gypsum - about 5% -20%, brick / ceramics: by 20% -50%, concrete / reinforced concrete: by 50% -80%, metal / steel: by 100%),
- driver availability for third parties and sabotage attempts,
- maintaining a safe distance from sources of possible interference (eg 230V / AC power buses - buildings, radio transmitters, etc.).

Connection and start-up of the AP-IP module.

Connection of the AP-IP communication module.

1. The AP-IP module should be installed on the OptimaGSM mainboard in accordance with the orientation and two sets of pins should be plugged into the sockets on the motherboard (see photo below).

In the case of the version in the housing for a DIN rail (- D9M), the housing should be opened by releasing the lateral hooks. Remove the control panel PCB, install AP-IP module, assemble the whole in reverse order and lead out the RJ12 / 4pin cable and the aerial FME wire.

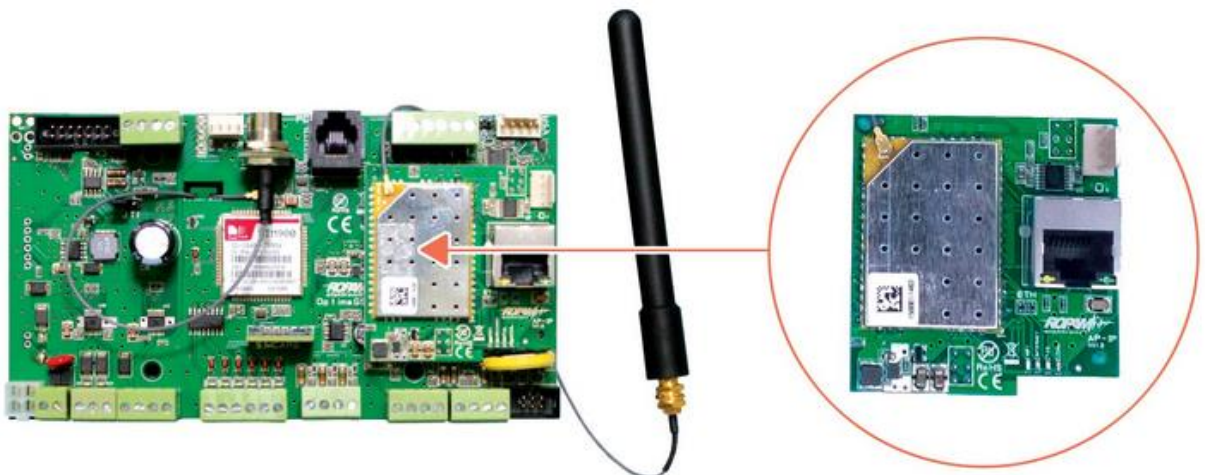

2. In case you used a Wifi connection, install a vertical Wifi antenna on the housing or cabinet,
3. If using an ETH connection, connect the UTP LAN cable to the ETH connector.
4. Connect the programming cable to the service computer: USB-MGSM or RS232-MGSM (selection depending on available ports in the service computer).
5. Start the OptimaGSM Manager program (in the version dedicated to a given control panel version), select the COM port for the communication cable, the connection will take place automatically.

6. Open the tab "Modules, TPR panels" to start "Identification" and detected modules, expanders including AP-IP to be rewritten to the control panel resources and save the settings to the control panel.

7. Configure the AP-IP module:

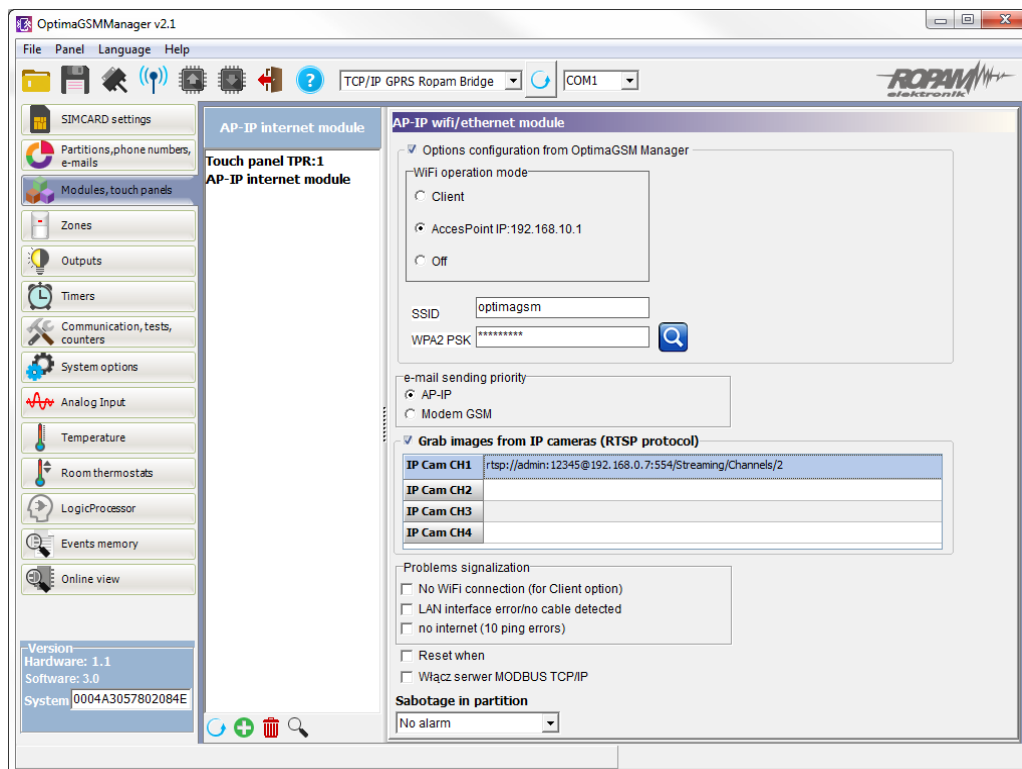

In the control panel, after upgrading from the lower version, there are no default settings for AP-IP and TCP / IP key.

For security reasons, the WPA2 password must be changed on the site unconditionally.

8. After configuring the control panel with the AP-IP module, connect the control panel and the AP-IP module with the 4pin / RJ12 cable:



Comments:

For security reasons, the WPA2 password must be changed on the site (minimum 8 characters).

When updating the system from an older version, please:

- **updating all elements to compatible versions,**
- **identification and programming of the current configuration program, dedicated to the latest versions,**
- **verification and possibly changes in functions, LogicProcessor scripts,**
- **deleting and creating new users of the system (codes) and granting them access to IP.**

Configuration.

The AP-IP module is based on a router with support for two Ethernet and WLAN networks connected by NAT (Network Address Translation).

The addressing of individual subnets must be different, e.g. 192.168.1.x and 192.168.10.x (default for WLAN).

Used ports (default):

- WebServer user: TCP port 443 (https: //),
- Router Administration Panel (LuCI): TCP port 444 (https: //),
- OptimaGSM Manager programming: TCP port 8882

Comments:

Ports to the router panel and TCP / IP programming are not recommended to be shared outside the local network.

Configuration: OptimaGSM Manager.

AP-IP module configuration options.

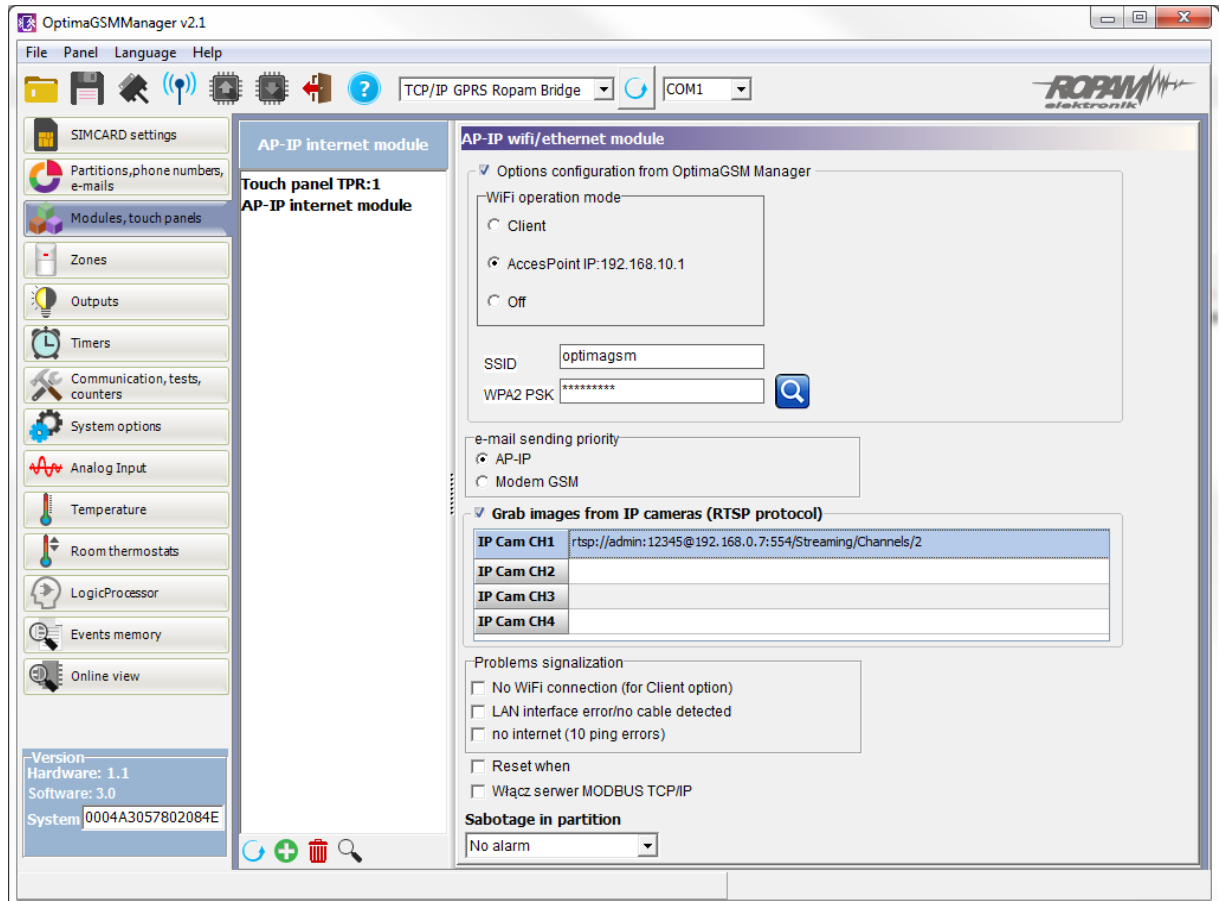

Configuration of the Wifi option with OptimaGSM Manager: Wifi router settings are possible only from the OptimaGSM Manager program (basic).

Wifi operating mode:

- **Client:** allows you to connect to another Wifi router (access point), work as a DHCP client, enter the access data to the Wifi network on the site in the SSID and WPA2-PSK fields,
- **AccessPoint:** the module works as a Wifi access point, work as a DHCP server, in the SSID and WPA2-PSK fields, enter authorization data for access devices, e.g. tablets, smartphones, PCs,
- **disabled:** disables Wifi interface, access to the web server only via ETH,
- **SSID:** field for entering the WLAN network name, in case of working as a Client of the existing network name and in the case of working as AccesPoint broadcast by AP-IP (SSID name can not contain a space character !!!).
- **WPA2-PSK:** the field for entering the Wifi password (minimum 8 characters) when working as a Client must be compatible with the password of the access point,

Priority of sending e-mail, TCP / IP:

- AP-IP

- modem GPRS

the option sets the default basic connection for TCP / IP communication.

Capture image from IP cameras (RTSP protocol)

A function that allows you to capture images from IP cameras using the RTSP protocol.

- cooperation with IP cameras and DVR recorders, capturing RTSP stream (4),
- for creating photos for MMS (GPRS) or e-mail attachments (IP, internet),

The RTSP stream should be configured from the cameras / DVR. The RTSP path can be checked using VLC. In the case of freeze frames, the frequency of images downloading can not be higher than 1 for 5s.

The AP-IP module settings window (configuration of access paths for IP cameras).

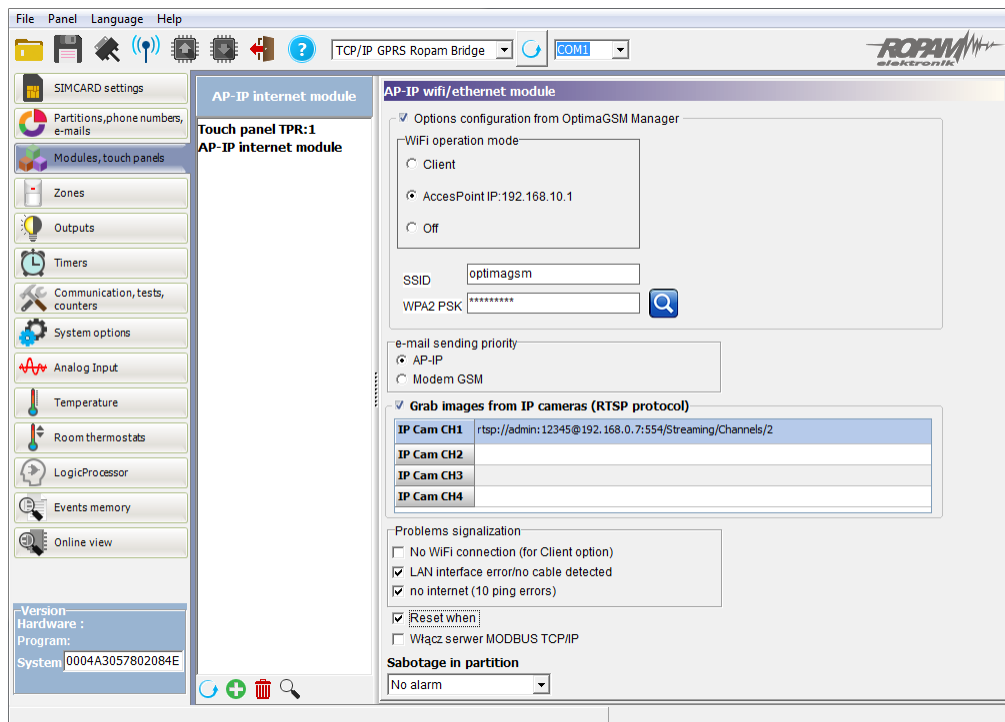

Notification settings window for outputs every 5s or simultaneously (MMS, e-mail).

Tel/e-mail	1	2	3	4	5	6	7	8
Sms to:	<input type="checkbox"/>	<input type="checkbox"/>	<input type="checkbox"/>	<input type="checkbox"/>	<input type="checkbox"/>	<input type="checkbox"/>	<input type="checkbox"/>	<input type="checkbox"/>
Call to:	<input type="checkbox"/>	<input type="checkbox"/>	<input type="checkbox"/>	<input type="checkbox"/>	<input type="checkbox"/>	<input type="checkbox"/>	<input type="checkbox"/>	<input type="checkbox"/>
MMS to:	<input checked="" type="checkbox"/>	<input type="checkbox"/>	<input type="checkbox"/>	<input type="checkbox"/>	<input type="checkbox"/>	<input type="checkbox"/>	<input type="checkbox"/>	<input type="checkbox"/>
MMS to e-mail	<input type="checkbox"/>	<input type="checkbox"/>	<input type="checkbox"/>	<input type="checkbox"/>	<input type="checkbox"/>	<input type="checkbox"/>	<input type="checkbox"/>	<input type="checkbox"/>
E-mail to:	<input type="checkbox"/>	<input type="checkbox"/>	<input type="checkbox"/>	<input type="checkbox"/>	<input type="checkbox"/>	<input type="checkbox"/>	<input type="checkbox"/>	<input type="checkbox"/>

Sms/e-mail content	
TCP/IP code	
VSR-2 messages	
Add pict. seq. to MMS/e-mail	<input checked="" type="checkbox"/>
FLASH type SMS	<input type="checkbox"/>
Add STATUS	<input checked="" type="checkbox"/>

Picture No.	1	2	3	4
Lenght[s]	0	5	10	15
Video Input	CH1	CH1	CH2	CH1

Tel/e-mail	1	2	3	4	5	6	7	8
Sms to:	<input type="checkbox"/>	<input type="checkbox"/>	<input type="checkbox"/>	<input type="checkbox"/>	<input type="checkbox"/>	<input type="checkbox"/>	<input type="checkbox"/>	<input type="checkbox"/>
Call to:	<input type="checkbox"/>	<input type="checkbox"/>	<input type="checkbox"/>	<input type="checkbox"/>	<input type="checkbox"/>	<input type="checkbox"/>	<input type="checkbox"/>	<input type="checkbox"/>
MMS to:	<input checked="" type="checkbox"/>	<input type="checkbox"/>	<input type="checkbox"/>	<input type="checkbox"/>	<input type="checkbox"/>	<input type="checkbox"/>	<input type="checkbox"/>	<input type="checkbox"/>
MMS to e-mail	<input type="checkbox"/>	<input type="checkbox"/>	<input type="checkbox"/>	<input type="checkbox"/>	<input type="checkbox"/>	<input type="checkbox"/>	<input type="checkbox"/>	<input type="checkbox"/>
E-mail to:	<input type="checkbox"/>	<input type="checkbox"/>	<input type="checkbox"/>	<input type="checkbox"/>	<input type="checkbox"/>	<input type="checkbox"/>	<input type="checkbox"/>	<input type="checkbox"/>

Sms/e-mail content	
TCP/IP code	
VSR-2 messages	
Add pict. seq. to MMS/e-mail	<input checked="" type="checkbox"/>
FLASH type SMS	<input type="checkbox"/>
Add STATUS	<input checked="" type="checkbox"/>

Picture No.	1	2	3	4
Lenght[s]	0	0	0	0
Video Input	CH1	CH2	CH3	CH4

Support for camera resolutions from:

CIF (352x288)
 2CIF: 704x288
 4CIF (704x576)
 D1: (720x576)
 HD 720P (1280x720)
 HD 1080P (1920x1080)

In the case of supporting an additional stream (auxiliary) by an IP camera, this stream should be selected as the base for downloading images.

The transmission quality for the auxiliary channel should be smaller than the main stream - it will ensure correct compression of the downloaded images.

Recommended not greater than D1.

In order for the path to the camera to be interpreted correctly, the whole address should be taken in quotation marks!

Example:

✓ Grab images from IP cameras (RTSP protocol)	
IP Cam CH1	rtsp://admin:12345@192.168.0.7:554/Streaming/Channels/2
IP Cam CH2	
IP Cam CH3	
IP Cam CH4	

Signaling problems:

- no connection to Wifi network (as Client)
- no UTP / ETH interface cable
- no internet (10 unsuccessful PING queries)

Selecting this option will signal FAIL failures if they occur.

Reset module when no internet for 5 minutes.

the option generates an automatic reset and restart of the AP-IP module with the restart of all network services.

Configuration and status control: SMS.

Checking the status and changing the **AP-IP configuration, i.e. IP, SSID, and WPA2 password**, is possible by:

1. In the touch panel, in the user menu (main password, from v1.3 panels).
2. During connection with OptimaGSM Manager, programming using AP-IP (the control panel must be in service mode, and the control panel ID must match, TCP / IP key, communication password).
3. SMS commands:

Command	Description
#### lanstat	read the IP address of the AP-IP assigned for the ETH wired connection (ETH DHCP client)
#### wifi	returns Wifi network status: IP, SSID, WPA2, RSSI, mode, internet IP - assigned IP address, SSID: the name of the Wifi network WPA2 - Wifi network password mode: set operating mode: client (0), accespoint (1), off (3) internet: there is / no
#### wifi mode ap / client / off ssid: [network_identifier] wpa: [password_path]	configuration of the Wifi network by SMS, parameters of the command should be given as command arguments, e.g. 5555 wifi mode ap ssid: apip wpa: ropam, SSID can not contain spaces!
#### apiprestart	the command restarts the AP-IP and restarts services (AP-IP run time and network services: ~ 30 sec.)
#### apipdefault	restores AP-IP default settings (ETH: DHC client, WLAN: Access Point, webserver https://192.168.10.1)

Comments:

- default WebServer for Wifi connection - AccesPoint is: https: 192.168.10.1
- SMS commands require authorization with the main code.

System configuration: TCP / IP AP-IP module.

If the AP-IP module is installed in the system and is connected to the Ethernet or Wifi network, it is possible to program the panel using TCP / IP.

Programming requires:

- access to the network with the AP-IP system and the open port 8882,
- the ability to enter the service mode in the control panel,
- the control panel can not be in armed mode (armed mode),
- knowledge: ID of the control panel, TCP / IP key, communication password with the PC (or file with the control panel configuration),

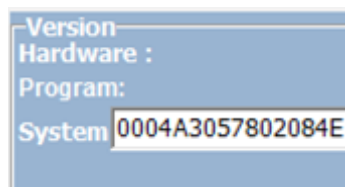

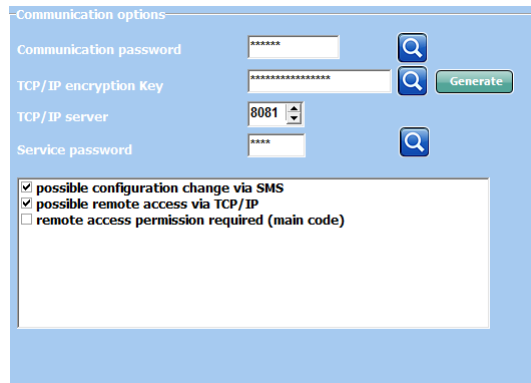

- TCP / IP remote programming option selected
 The LAN / WiFi network parameters can be read out from the touch panel - user settings -> Internet module (TPR-1x, TPR-2x, TPR-4):

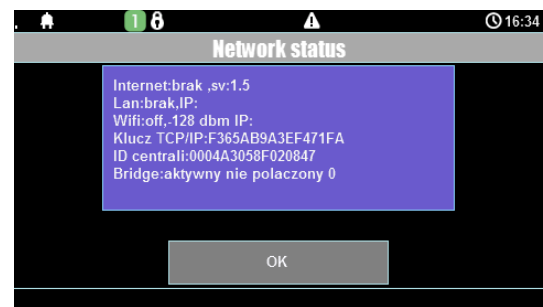
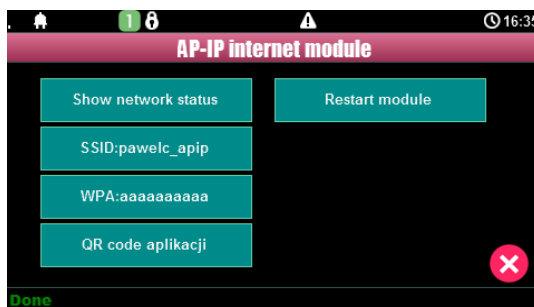

Programming TCP / IP using AP-IP:

- start OptimaGSM Manager, enter the ID of the control panel, TCP / IP key, PC communication password (or open the file with the system configuration),
- select from the connection mode: TCP / IP AP-IP module,



- press the 'antenna' remote connection button (the fourth icon from the left),
- start the control panel service mode during connection attempts (20), if the system does not have a programmed touch panel, the service mode can be started by putting a jumper on connector X3 (third vertical pair from the PCB edge), after programming the jumper must be removed!

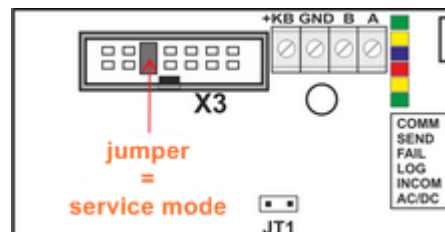

- the OptimaGSM Manager program broadcasts an incoming TCP / IP connection with the control panel ID and usually the connection is established automatically, if the control panel does not respond automatically, the window for entering the control panel IP will be displayed.

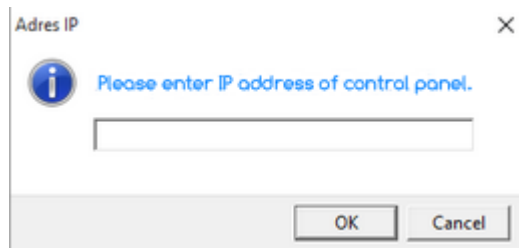

(read IP address for ETH network is possible through: touch panel - user menu, SMS command, on the OptimaGSM bottom bar during the TCP / IP connection set-up, the default IP for WLAN: 192.168.10.1).

Comments:

By default AP-IP has the following settings (in the original configuration of OptimaGSM 1.9 and higher):

- AP-IP module programmed in the control panel configuration,
- configuration of the Wifi option from the OptimaGSM Manager level,
- operating modes: Wifi- AccesPoint with DHCP server (default IP address: https://192.168.10.1)

SSID: apip

WPA2: ropam_optimagsm

- ETH mode of operation: DHCP client,
- TCP / IP key = ID of the control panel (see sticker)
- communication password with PC: 111111

The above settings allow programming through the TCP / IP of the factory OptimaGSM control panel!

Advanced configuration of the router.

The AP-IP router is based on the OpenWrt software with the LuCI graphic environment. The change of advanced functions is possible after logging into the administration panel.

In the case of configurations from the LuCI level, the configuration option must be disabled from the OptimaGSM Manager level.

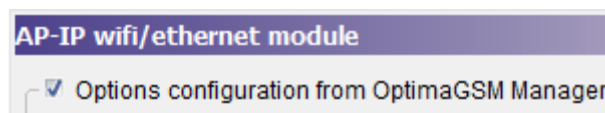

Login to the LuCI administration panel:

- port 444 of the web server's IP address, e.g. https://192.168.10.1: 444
- 'router' icon in the user's application:

Login data:

login: root
password: ID of the headquarters (OptimaGSM)
(see sticker, file with system configuration)

Ap-IP

Authorization Required

Please enter your username and password.

Username Password

Ropam Elektronik

Comments:

- advanced configuration requires knowledge of OpenWrt based network configuration and routers,
- in the installer and ftp zones with application notes there are examples of configuration changes, e.g. permanent IP for ETH, changing the addressing of the ETH network, WLAN, change of ports for WebSewrer and LuCI.

Providing a fixed IP address.

The procedure for assigning a fixed address for the ETH interface is shown below.

In some cases, it is necessary to give a fixed IP for the correct operation of the OptimaGSM system (when there are problems with the assignment of addressing via DHCP).

To give a permanent IP for the required interface:

Log in to the exchange via the browser:

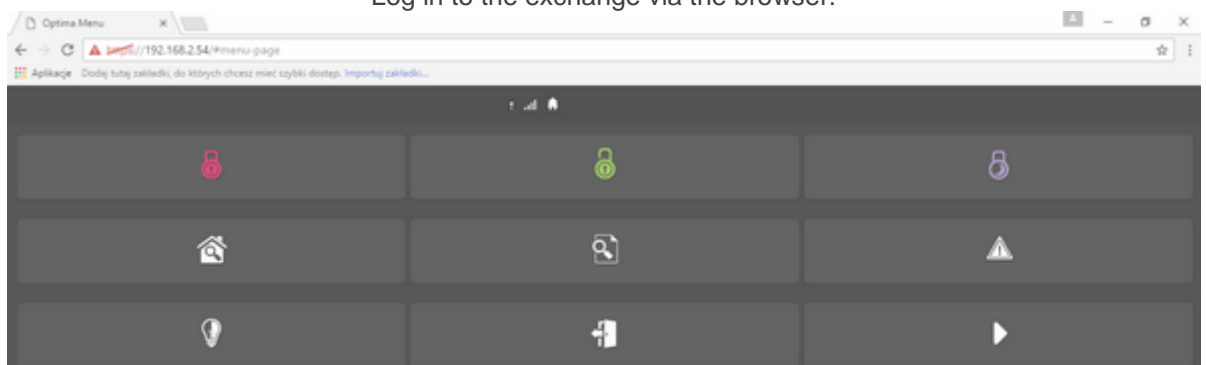

Go to the "Ustawienia (Settings)" tab:

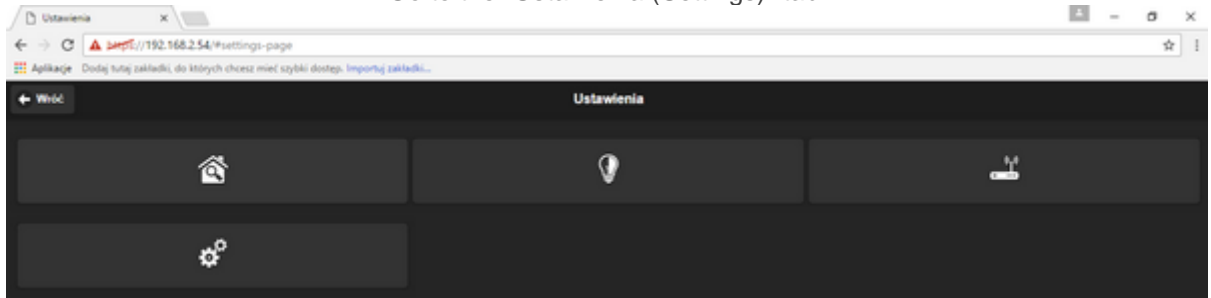

Click the router icon:



And choose interface menu to change the IP address:

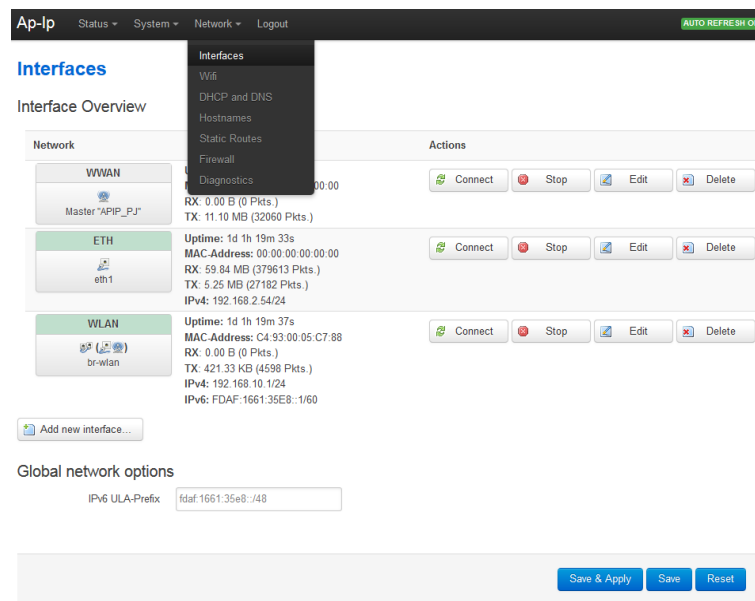

Editing a given interface launches the address change menu:

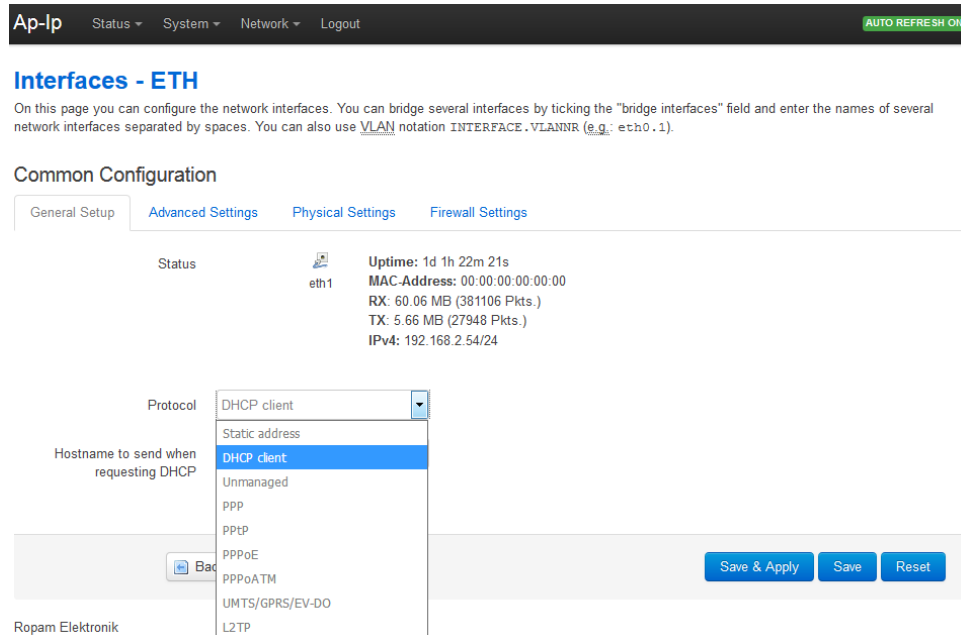

After correct configuration of addresses, you should save your swaps by clicking "Save and apply".

System maintenance.

The device does not require any special maintenance. During periodic technical inspections, it is necessary to check the condition of screw joints, emergency power supply status, clean the PCB with compressed air. The system should be periodically tested for proper operation and communication.

Technical parameters.

Parameter	Value
Power supply voltage	U= 9V÷15VDC from control panel
Power consumption, power	I= 40-80mA @12V (0,3-0,6W)
Ethernet	10/100 BaseT, RJ45
WLAN	WiFi 802.11 b / g / n, 2.4 GHz, 150 Mb, 21dB max. Transmit power, antenna modem 'to the housing' (0 dBi)
Working conditions	environmental class: II, temp.: 10 ° C ... + 55 ° C RH: 20% ... 90%, no condensation
Dimensions	54x56x30 WxHxD [mm]

Version history.

AP-IP	Date	Description
1.0	2015.09.15	- the first version of AP-IP (required versions: OptimaGSM Manager1.5, OptimaGSM v1.9, TPR-xx_OptimaGSM v1.3)
1.1	2015.11.27	* new features: - the default IP of the webserver for Wifi (WLAN) connection has been changed: https://192.168.10.1 (v1.0 had https://192.168.1.1 and addressing conflicts could have occurred if ETH was 192.168.1.x) * corrections: - the display of negative temperatures from TSR-xx sensors is improved
1.2	2015.12.07	* new features: - added service mode signaling in WebServer, orange top bar, * corrections: - improved functions of user password encryption (login was only possible for passwords with the same characters),
1.3	2016.04.01	* new features: - cooperation with IP cameras and DVR recorders, capturing RTSP stream (4) for creating photos for MMS (GPRS) or e-mail attachments (IP, internet)
1.4	2016.08.05	* new features: - support for the RopamOptima application on mobile devices
1.5	2016.10.06	* new features: - Modbus protocol support

EXP-I8-RN**General description.**

The EXP-I8-RN module is used to extend the functionality of the system by 8 configurable inputs as in the control panel.

Properties

- 8 additional entries in the system,
- 2EOL / NC operation configuration, 2EOL / NO, EOL, NC, NO,
- module on the RopamNET bus, local or elevated work - bus length up to 200mb,
- configuration, properties and types of reactions like OptimaGSM inputs,
- transmission from EXP-I8-RN inputs: SMS / MMS / VOICE / CLIP / IP.
- disconnect terminal connectors.

Destiny.

EXP-I8-RN is an input module that cooperates with the OptimaGSM / OptimaGSM-PS alarm panel. The module increases the number of entries in the system by eight.

Warnings.

- For safety reasons, the device should only be configured by qualified installers.
- Before proceeding to configuration, read the understanding with the above instructions.
- Do not interfere with the construction or carry out independent repairs.
- It is necessary to maintain possible antistatic protection measures to protect electronic circuits on PCBs against electrostatic discharge ESD.
- In order to meet the requirements of LVD and EMC, the following rules must be observed: power supply, installation, shielding - according to the application.

Description of the module

Module versions.

Code	Description
EXP-I8-RN	Zone expander module (additional 8 zones in the system), communication - RopamNET bus
EXP-I8-RN-D4M	Zone expander module (additional 8 zones in the system), communication - RopamNET bus, DIN rail housing, width 4 modules

Construction and description.

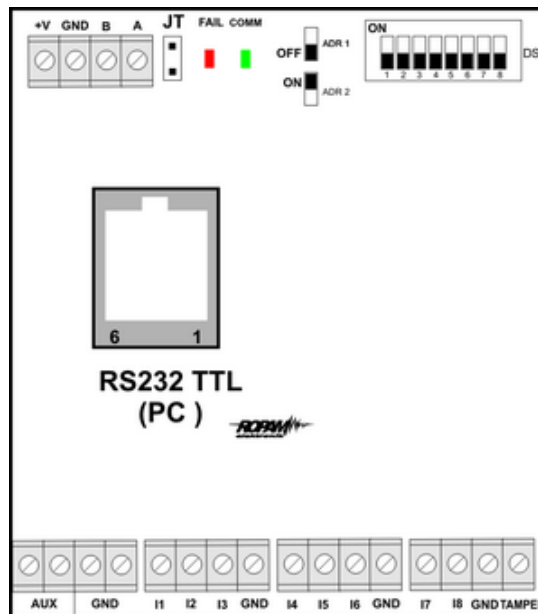

View of the EXP-I8-RN module

Description of the module.

Description	Properties
+V, GND	9-14VDC module power terminals
A,B	RopamNET communication bus (EIA 485)
JT	jumper terminating the RopamNET bus (only assumed if the module is located at the end of the communication bus).
LEDs:	<ul style="list-style-type: none"> - FAIL red - failure, no communication with the control panel or modules connected to the OptimaGSM system or simple PLC system - COMM green - communication with the control panel or modules connected to the OptimaGSM system or simple PLC system
DS1	Dip Switch to set the module address in the system - see image.
AUX GND	power output terminals protected with a 300mA polymer power supply (power supply for detectors).
I1-I8	module inputs, parameterized identically to the OptimaGSM panel inputs
Tamper	External temperature input for the module, status displayed and operated from the OptimaGSM control panel.

Optical signaling of the state.

Operating status indication - LED diodes

LED	COLOR	SIGNALING NORMAL STATUS	SIGNALING OF FAILURE
COMM	GREEN	<ul style="list-style-type: none"> • short flashes every 1s = correct communication with the module 	<ul style="list-style-type: none"> • shines - no communication with the module, module not identified by the control panel.
FAIL	RED	<ul style="list-style-type: none"> • does not light - correct operation of the module • blinks every 0.5s - entering the firmware upgrade mode (active bootloader, PR jumper installed) 	<ul style="list-style-type: none"> • shines - no communication with the module

Requirements, installation.

Basic requirements.

EXP-I8-RN zone expander module should be used in conditions with normal air humidity (RH = 90% max. Without condensation) and temperature in the range of -10 ° C to + 55 ° C. It is absolutely necessary to observe the rules of assembly of devices for low-current networks (power supply, data bus, cabling).

Installation and connection of the module.

1. Install the module in a suitable place (switchgear, external surface-mounted housing) and connect in accordance with the description of the terminals, maintaining particular obstruction when connecting the power cables.
2. Connect the RopamNET bus cables of the module to the OptimaGSM control panel or the Simple PLC system according to drawing below.
3. Configure module inputs by needs (parameters identical to those for the OptimaGSM central office).
4. Perform functional tests, check operation.
5. After completing the installation, perform user training.

Comments:

It is necessary to keep possible antistatic protection measures to protect electronic circuits on PCBs against electrostatic discharge ESD.

Module connection:

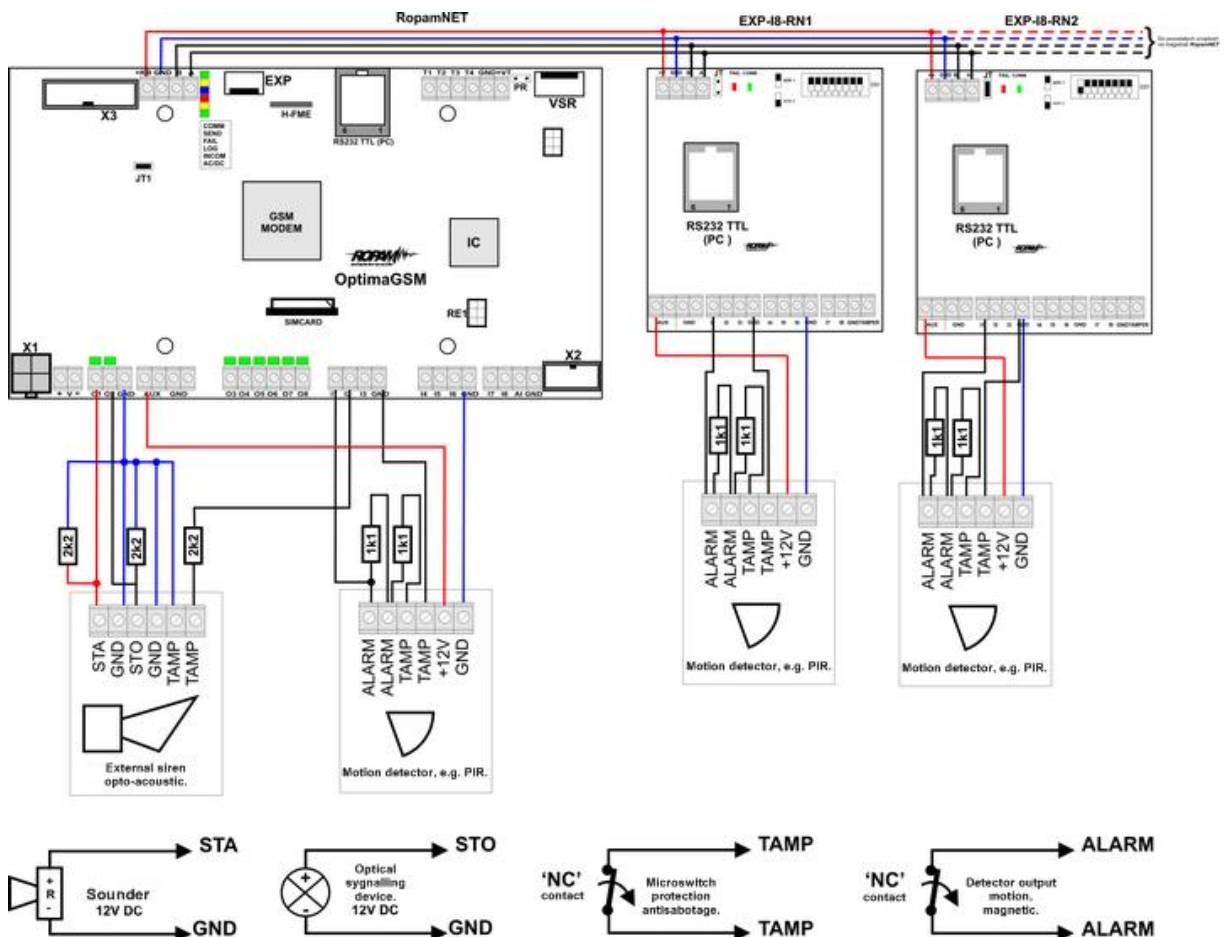

Line polarizations possible:

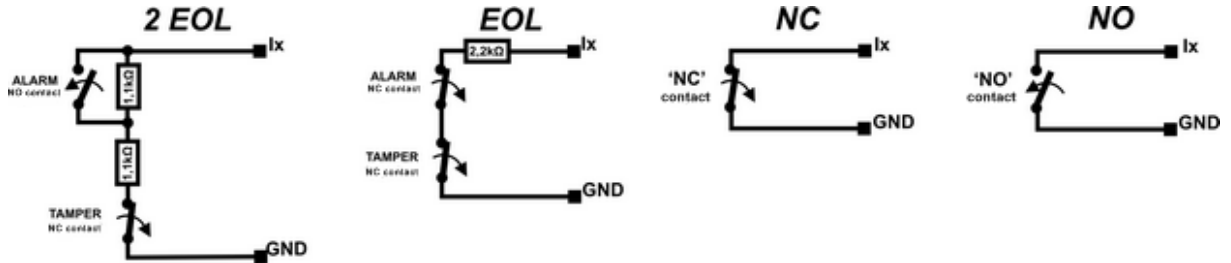

Technical parameters.

Parameter	Value
Power supply voltage	U = 9 - 14VDC from the connector + KB, GND
Power consumption	20mA/40mA min/max (Ix=2,5mA @12VDC)
Zones I1-I8	NO, NC, EOL, 2EOL/NC, 2EOL/NO = hi-Z/~30 , ~30 /hi-Z, hi-Z/2k2, 1k1/2k2, 2k2/1k1 line impedance for a given type [Ohm]: no violation / violation
Communication	EIA 485 RopamNET
Work signaling	LEDs: red - failure, green - communication, no communication
Working conditions	environmental class: II temp.:10°C ... + 55°C RH: 20% ... 90%, no condensation
Dimensions	67.5 x 25 x 87 (WxHxD, mm) without mounting studs, 67.5 x 30 x 87 (WxHxD, mm) with mounting studs 71mm x 57.5 x 90.7 (WxHxD, mm) housing for DIN rail, width 4 modules
Weight	~50g / ~100g.

Version history.

Version	Date	Description
1.0	2015.04.02	First version
1.1	2015.09.10	Improve performance
1.2	2015.11.26	Version with bootloader

EXP-O8T-RN

General description.

Properties.

- 8 additional outputs in the system,
- configuration of operation NO, NC,
- module on the RopamNET bus, local or elevated work - bus length up to 200mb,
- configuration, properties and types of reactions like OptimaGSM inputs,
- transmission from EXP-I8-RN inputs: SMS / MMS / VOICE / CLIP / IP.
- disconnect terminal connectors.
- assembly in a housing for a DIN rail (version - D4M).

Destiny.

EXP-O8T-RN is an output module cooperating with the OptimaGSM / OptimaGSM-PS alarm panel. The module increases by eight number of transistor outputs (GND control, Rdc 500mOhm) in the system.

Warnings.

- For safety reasons, the device should only be configured by qualified installers.
- Before proceeding to configuration, read the understanding with the above instructions.
- Do not interfere with the construction or carry out independent repairs.
- It is necessary to maintain possible antistatic protection measures to protect electronic circuits on PCBs against electrostatic discharge ESD.
- In order to meet the requirements of LVD and EMC, the following rules must be observed: power supply, installation, shielding - according to the application.

Description of the module.

Module versions.

Code	Description
EXP-I8-RN	Zone expander module (additional 8 zones in the system), communication - RopamNET bus
EXP-I8-RN-D4M	Zone expander module (additional 8 zones in the system), communication - RopamNET bus, DIN rail housing, width 4 modules

Construction and description.

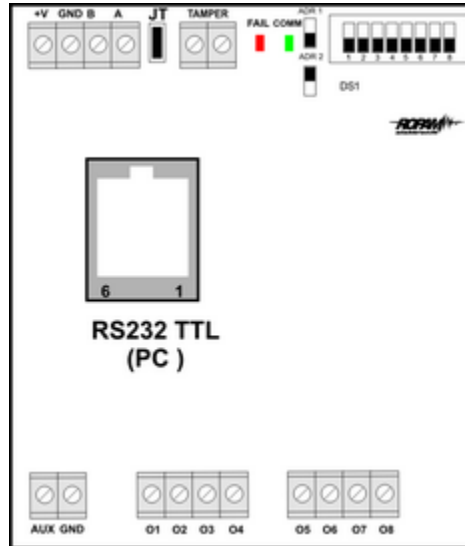

View of the EXP-I8-RN module

Description of the module.

Description	Properties
+V, GND	9-14VDC module power terminals
A,B	RopamNET communication bus (EIA 485)
JT	jumper terminating the RopamNET bus (only assumed if the module is at the end of the communication bus).
LEDs:	<ul style="list-style-type: none"> - FAIL red - failure, no communication with the control panel or modules connected to the OptimaGSM system or simple PLC system - COMM green - communication with the control panel or modules connected to the OptimaGSM system or simple PLC system
DS1	Dip Switch to set the module address in the system - see image.
AUX GND	12VDC power output terminals protected with a 100mA polymer gloss
O1-O8	module outputs, parameterized in the same way as the OptimaGSM panel inputs, 0.7A @ 24VDC, GND control
Security	short-circuit OCP, overload OLP, thermal OHP, OVP overvoltage
Tamper	external temperature input for the module, status displayed and operated from the OptimaGSM control panel.

Optical signaling of the state.

Operating status indication - LED diodes

<i>LED</i>	<i>COLOR</i>	<i>SIGNALING NORMAL STATUS</i>	<i>SIGNALING OF FAILURE</i>
COMM	GREEN	<ul style="list-style-type: none"> • short flashes every 1s = correct communication with the module 	<ul style="list-style-type: none"> • light - no communication with the module, module not identified by the control panel.
FAIL	RED	<ul style="list-style-type: none"> • does not light - correct operation of the module • blinks every 0.5s - entering the firmware upgrade mode (active bootloader, PR jumper installed) 	<ul style="list-style-type: none"> • light - no communication with the module

Requirements, installation.

Basic requirements.

EXP-18-RN zone expander module should be used in conditions with normal air humidity (RH = 90% max. Without condensation) and temperature in the range of -10 ° C to + 55 ° C. It is absolutely necessary to observe the rules of assembly of devices for low-current networks (power supply, data bus, cabling).

Installation and connection of the module.

1. Install the module in a suitable place (switchgear, external surface-mounted housing) and connect in accordance with the description of the terminals, maintaining particular obstruction when connecting the power cables.
2. Connect the RopamNET bus cables of the module to the OptimaGSM control panel or the Simple PLC system according to drawing below.
3. Configure module inputs by needs (parameters identical to those for the OptimaGSM central office)
4. Perform functional tests, check operation.
5. After completing the installation, perform user training.

Comments:

It is necessary to keep possible antistatic protection measures to protect electronic circuits on PCBs against electrostatic discharge ESD.

Module connection:

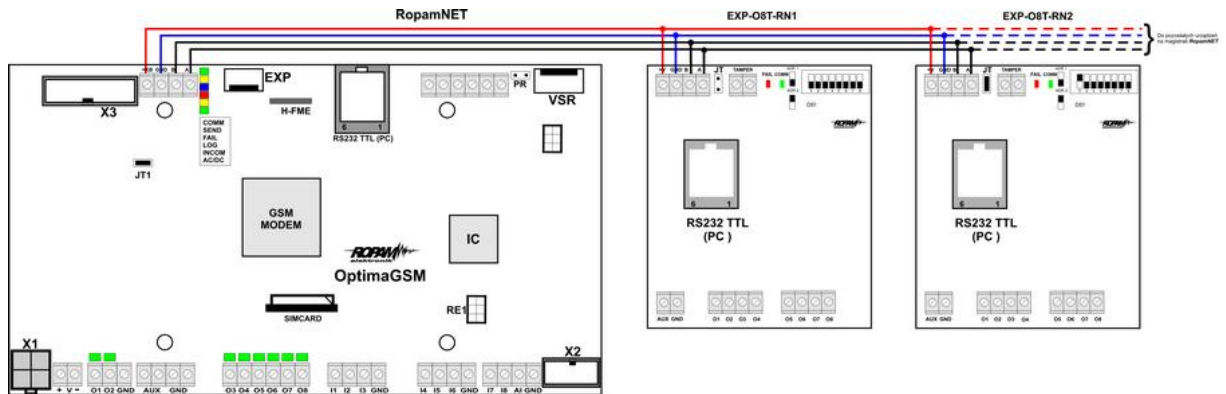

System maintenance.

The device does not require any special maintenance. During periodic technical inspections, check the condition of the screw joints, clean the PCB with compressed air.

Technical parameters.

Parameter	Value
Power supply voltage	U = 9 - 14VDC from the connector + KB, GND
Power consumption	20mA/60mA min/max @12VDC
Outputs O1-O8	NO, NC, RDC 500mOhm, 700mA@24VDC
Communication	EIA 485 RopamNET
Work signaling	LEDs: red - failure, green - communication, no communication
Working conditions	environmental class: II temp.:10°C ... + 55°C RH: 20% ... 90%, no condensation
Dimensions	67.5 x 25 x 87 (WxHxD, mm) without mounting studs, 67.5 x 30 x 87 (WxHxD, mm) with mounting studs 71mm x 57.5 x 90.7 (WxHxD, mm) housing for DIN rail, width 4 modules
Weight	~50g / ~100g.

Version history.

Version	Date	Description
1.0	2015.09.01	First version

EXP-O8R-RN

General description.

Properties.

- 8 additional outputs in the system,
- configuration of operation NO, NC,
- module on the RopamNET bus, local or elevated work - bus length up to 200mb,
- configuration, properties and types of reactions like OptimaGSM inputs,
- disconnect terminal connectors.
- C, NO, NC potential-free contacts
- high quality relays (AC1: 16A / 250V, AC3: 750W single-phase motor)
- assembly in a housing for a DIN rail (width 9 modules).

Destiny.

EXP-O8R-RN is an output module cooperating with the OptimaGSM / OptimaGSM-PS alarm control panel or the SimplePLC system.

The module increases by eight the number of relay outputs (AC1: 16A / 250V, AC3: 750W 1-phase motor, contacts: C / NO / NC) in the system.

Warnings.

- For safety reasons, the device should only be configured by qualified installers.
- Before proceeding to configuration, read the understanding with the above instructions.
- Do not interfere with the construction or carry out independent repairs. • It is necessary to maintain possible antistatic protection measures to protect electronic circuits on PCBs against electrostatic discharge ESD.
- In order to meet the requirements of LVD and EMC, the following rules must be observed: power supply, installation, shielding - according to the application.

Description of the module

Module versions.

Code	Description
EXP-O8R-RN-D9M	Expander module of relay outputs (additional 8 relay outputs in the system), communication - RopamNET bus, housing for DIN rail, width of 9 modules

Construction and description.

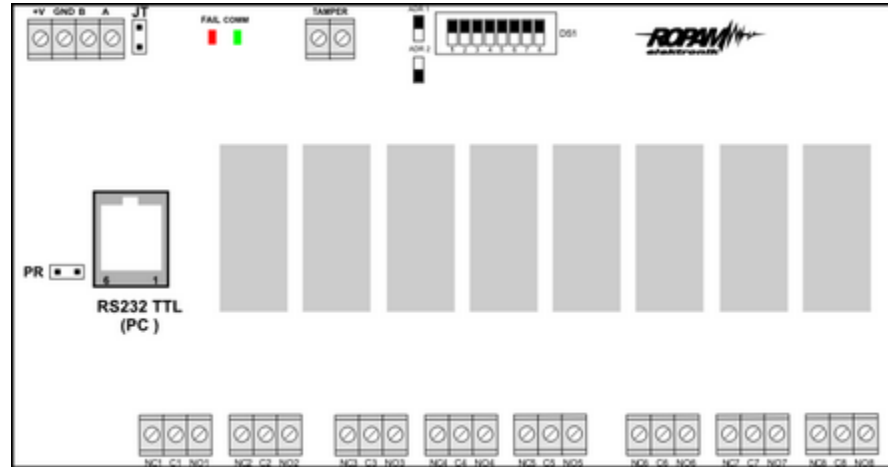

View of the EXP-I8-RN module

Description of the module.

Description	Properties
+V, GND	9-14VDC module power terminals
A,B	RopamNET communication bus (EIA 485)
JT	jumper terminating the RopamNET bus (only assumed if the module is at the end of the communication bus).
Diody LED:	<ul style="list-style-type: none"> - FAIL red - failure, no communication with the control panel or modules connected to the OptimaGSM system or simple PLC system - COMM green - communication with the control panel or modules connected to the OptimaGSM system or simple PLC system
DS1	Dip Switch to set the module address in the system - see image.
NCx,Cx,NOx	relay contact terminals, NO - normally open contact, C - common contact, NC - normally closed contact
O1-O8	module outputs, parameterized in the same way as the OptimaGSM control panel inputs, (AC1: 16A / 250V, AC3: 750W 1-phase motor)
Montaż	DIN-TS35 DIN rail housing, 9 modules wide
Tamper	External temperature input for the module, status displayed and operated from the OptimaGSM control panel.

Optical signaling of the state.

Operating status indication - LED diodes

LED	COLOR	SIGNALING NORMAL STATUS	SIGNALING OF FAILURE
COMM	GREEN	<ul style="list-style-type: none"> short flashes every 1s: correct communication with the module 	<ul style="list-style-type: none"> shines - no communication with the module, module not identified by the control panel.
FAIL	RED	<ul style="list-style-type: none"> does not light - correct operation of the module blinks every 0.5s - entering the firmware upgrade mode (active bootloader, PR jumper installed) 	<ul style="list-style-type: none"> shines - no communication with the module

Requirements, installation.

Basic requirements.

EXP-O8R-RN output expander module should be used in conditions with normal air humidity (RH = 90% max. Without condensation) and temperature in the range of -10 ° C to + 55 ° C.

It is absolutely necessary to follow the installation rules of the devices to the 230VAC mains (power supply, cabling).

It is absolutely necessary to observe the rules of assembly of devices for low-current networks (power supply, data bus, cabling).

Installation and connection of the module.

1. Install the module in a suitable place (switchgear, external surface-mounted housing) and connect in accordance with the description of the terminals, maintaining particular obstruction when connecting the power cables.
2. Connect the RopamNET bus cables of the module to the OptimaGSM control panel or the Simple PLC system according to drawing below.
3. Configure module inputs by needs (parameters identical to those for the OptimaGSM central office)
4. Perform functional tests, check operation.
5. After completing the installation, perform user training.

Comments:

It is necessary to keep possible antistatic protection measures to protect electronic circuits on PCBs against electrostatic discharge ESD.

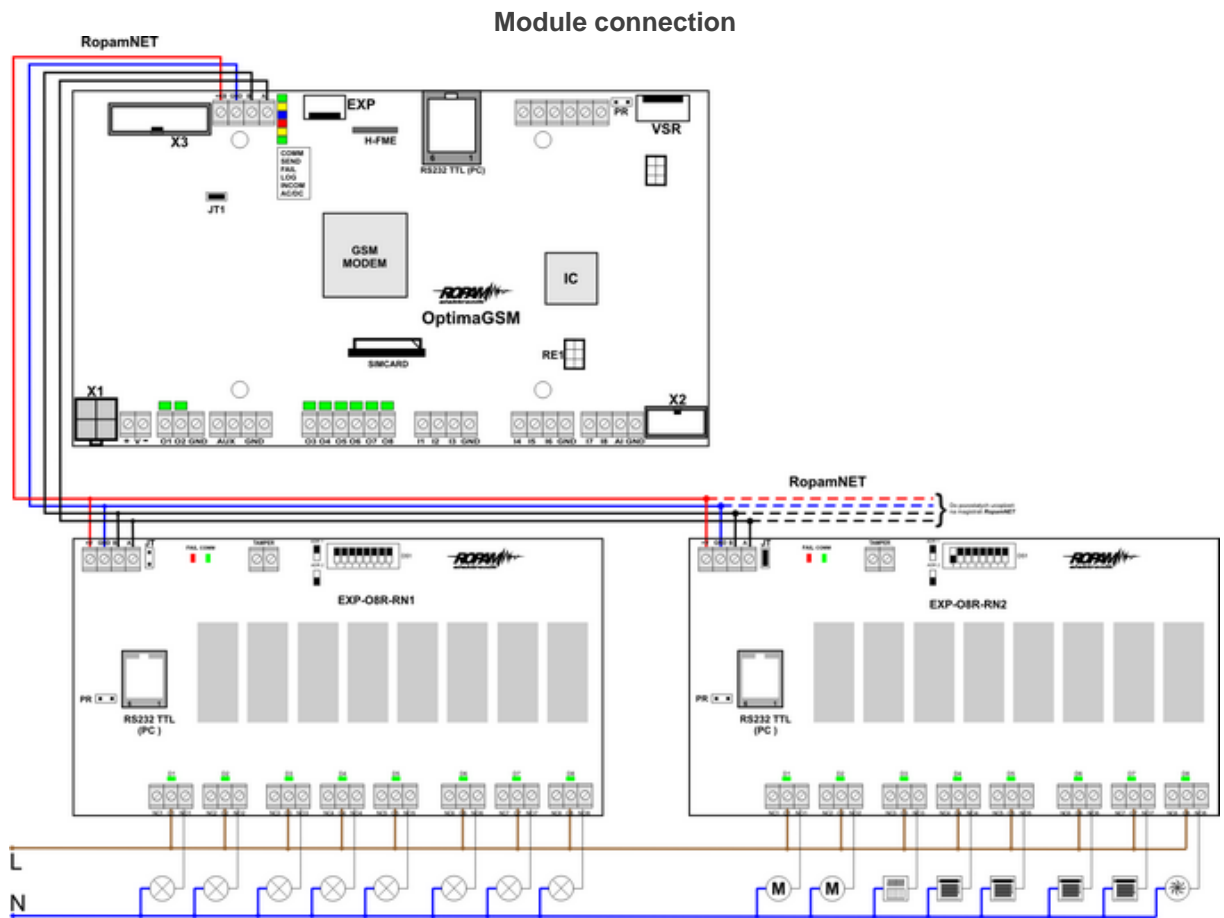

System maintenance.

The device does not require any special maintenance. During periodic technical inspections, check the condition of the screw joints, clean the PCB with compressed air.

Technical parameters.

Parameter	Value
Power supply voltage	U = 9 - 14VDC from the connector + KB, GND
Power consumption	300mA max @12VDC
Outputs O1-O8	C, NO, NC, (AC1: 16A / 250V, AC3: 750W 1-phase motor)
Communication	EIA 485 RopamNET
Work signaling	LEDs: red - failure, green - communication, no communication
Working conditions	environmental class: II temp.:10°C ... + 55°C RH: 20% ... 90%, no condensation
Dimensions	159.5 mm x 57.5 x 90.2 (WxHxD, mm) housing for DIN rail, 9 modules width

Parameter	Value
Weight	~320g.

Version history.

Verion	Date	Description
1.0	2015.04.02	First version

APm-AERO

General description.

Properties.

- Aero system controller (AP AccessPoint),
- support for 8 to 16 Aero devices in system mode,
- compliance with SSWiN PN-EN 50131-1 step 2,
- bi-directional, encrypted (AES 128-bit) communication in the ISM 868 MHz band,
- high RF sensitivity up to -110 dBm,
- automatic control of transmit power, up to + 10dBm, depending on strength (RSSI) and transmission quality (LQI),
- range above 300m in the open area,
- RopamNET bus for system communication,
- programming and diagnostics of the controller and Aero devices from the control panel level,
- full supervision and status transfer to Aero devices, presence control, link quality, battery status,
- the unique ID-Aero of each controller allows for proper operation within the range of another Aero system,
- non-volatile configuration memory,
- optical work signaling,
- power supply: 9V ÷ 14V / DC,
- white ABS surface-mounted housing - dimensions: 80x80x25 [mm],
- cooperation with the following systems: NeoGSM (from v1.9), OptimaGSM (from 2.1),
- in NeoGSM systems, the Aero controller or the EXP-I8 local expander can be operated,
- anti-sabotage protection,

Destiny.

The controller, the access point (AP) of the Aero system is intended for the integration of Aero wireless devices with Ropam Elektronik systems through the RopamNET Mastercard. The controller supervises and collects information from Aero wireless devices.

Warnings.

- For safety reasons, the device should only be configured by qualified installers.
- Before proceeding to configuration, read the understanding with the above instructions.
- Do not interfere with the construction or carry out independent repairs. • It is necessary to maintain possible antistatic protection measures to protect electronic circuits on PCBs against electrostatic discharge ESD.
- In order to meet the requirements of LVD and EMC, the following rules must be observed: power supply, installation, shielding - according to the application.

Controller description.

Controller versions.

Code	Description
APm-Aero	System controller Aero (AP Access Point), RopamNET bus, surface-mounted white ABS housing - dimensions: 80x80x25 [mm].
AP-Aero	Standalone or system Aero controller (AP Access Point), RopamNET bus, autonomous operation without a central office: control and supervision via I / O, local programming, LCD, housing mounted white ABS - Dimensions: 120x80x25 [mm]

Construction and description.

Element (vice)	Description, function
12V	DC power input: 9V ÷ 14 V / DC
GND	voltage terminal GND (0V) 'ground' power (GND-GND)
A, B	ROPamNET EIA485 system bus connector, connection principle A-A, B-B (GND-GND)
STATUS**	LED diode - green operation indicator: system work on the RopamNET bus Every 0.5s flashes = correct work and communication shines = correct power supply no connection via RopamNET

Assembly and installation.

Basic requirements.

The controller should be installed in closed rooms with normal air humidity (RH = 90% max. Without condensation) and temperature in the range of -10 ° C to + 55 ° C. When choosing a mounting location, the following criteria should be followed:

- range of the radio controller (attenuation of the walls of the room: wood / gypsum - about 5% -20%, brick / ceramics: by 20% -50%, concrete / reinforced concrete: by 50% -80%, metal / steel: by 100%),
- assembly optimally centrally in relation to the expected range (radius) of pilots work,

- driver availability for third parties and sabotage attempts,
- maintaining a safe distance from sources of possible interference (eg 230V / AC power buses - buildings, radio transmitters, etc.).

Installing the controller.

1. Install the controller housing in a suitable place and enter the appropriate wiring through the cable glands.
2. Connect the power wires to the terminals. In the case of NEO / NeoGSM:
+ KB - 12V, GND – GND.
3. Connect, in cooperation with the NEO / NeoGSM system, the RopamNET bus (3-wire):
A-A, B-B, GND-GND.
4. Connect (optional) the device to the controller outputs.
5. Start the system, turn on the controller's power supply.
6. Program the controller: in system operation from the central-control panel and the Partner GSM application,
7. Perform functional tests, check range.
8. After completing the installation, perform user training.

Comments:

It is necessary to keep possible antistatic protection measures to protect electronic circuits on PCBs against electrostatic discharge ESD.

Configuration.

Configuration: Partner GSM / OptimaGSM Manager.

The controller during system operation on the RopamNET bus is configured from the level of the control panel:

Requirements:

- cooperation with the following systems: NeoGSM (from v1.9),
- cooperation with the following systems: OptimaGSM (from v2.1),
- Partner GSM program in a version dedicated to a given version of the exchange, version from Partner GSM 4.5
- OptimaGSM manager program: (version from v1.9)

OptimaGSM Manager: AP-Aero

OptimaGSM program tab; APx-Aero.

The controller configuration and the RSSI radio signal level are available.

Warning:

- the zone type should be configured in the entry tab, PIR Aero detectors support modes operating in the armed mode (supervision):

NORMAL, ORDINARY QUIET, DELAYED, LATE DELAY, COUNTER.

Device status window (detectors):

ID: Device number in the controller -> entry number in the system, e.g. ID 1-> I13 ... ID8-> I20 for NeoGSM / NEO.

Type: Aero device type.

Violation: state of the detector, motion detection.

Tamper: state of anti-sabotage circuit.

Slevel: communication level Aero (Excellent / Good / Weak), results from RSSI and LQI parameters.

RSSI: radio signal level (range -20 to -110 dBm).

Note: If there is another transmitter on the 868MHz band nearby, the RSSI reading (background) is lower, for the system it is a disturbance, increased ISM background.

LQI: radio transmission quality, lower value = better quality,

Vbat [V]: battery voltage in the detector, the new battery has 3.5-3.6V.

Note: after installing the new battery reaches its nominal parameters only after about 24 hours of work in the detector, this is due to the battery construction, very low power consumption by the detector, ambient temperature.

Connection with AP: status of communication with the detector.

Sensitivity: sensitivity parameter of the detector detection algorithm.

1: lowest sensitivity

...

8: highest sensitivity

Low sensitivity values also reduce the real detection range. For applications in which animal resistance (PET) is to be used, use parameters 1 to 4.

Pulses: signal analysis time parameter, SmartPIR algorithm.

PULSE 1: the shortest sampling time, signal analysis

... ..

PULSE 4: the longest sampling time, signal analysis

The parameter specifies the sampling time for the SmartPIR algorithm. Each value allows effective detection, under normal conditions it is recommended to use PULSE 1-2 and for applications in which there may be interference or be resistant to animals (PET) PULSE 3-4.

PetImmunity: the detector has the option of resistance to pets: cats, dogs up to 40 cm high and up to 30 kg and rodents. The detector has a default resistance to animals up to 12 kg. The detector must be mounted to a perpendicular wall relative to the floor, at the nominal height, do not point the detector on the bracket towards the floor. Animals can move around the floor of the protected area. The protected area must not contain furniture, shelves on which animals can move. The detector requires proper configuration regarding sensitivity and time of analysis (Pulse).

Configuration of detectors:

Learning mode: launches learning mode, adding new detectors,

Procedure:

- open the detector and install the battery in the first detector according to the polarity. The detector after setting up the connection with the AP will generate two series of flashes (blue diode) with the device number in the AP (eg address 2 two series of flashes after two flashes),

- repeat point 2 for all detectors, detectors receive system no. According to the order of addition,

- check the status of detectors in the controller (RSSI, LQI), change the configuration for individual detectors, save the settings to detectors from the AP level.

Remove detector no. X: removes the selected detector from the controller's memory, x; 1-16 (currently connected to AP).

Delete all detectors: the function removes all detectors from the controller (currently connected to the AP).

Read the detector settings: the function gets settings from the detectors.

Send sensor settings: the function sends settings to all detectors.

Enable WalkTest: the option activates the detector test mode, motion detection with the WalkTest diode. Active mode only during programming also results in more frequent interval than those of Aero supervising devices (RSSI Vbat).

Wireless communication interval: the detector status control interval has three intervals: 30/60/90 s (60s by default). For maximum battery life, select the interval of 90 seconds. **The control interval affects how long the AP command will be sent to the detector, including: watch (supervision), WalkTest. All alarms, sabotages are sent without delay to the AP controller.** The detector automatically controls the transmission power, in order to obtain effective communication and for maximum battery life.

Comments:

If the detector / transmitter is not connected to the AP (eg after turning off the AP power supply), the detector goes into the power saving state. **Subsequent attempts to connect and synchronize take place every 10 minutes.** The blue LED indicates a series of 10x flashes every 10 minutes.

Loss of wireless communication (disarmed): the function allows you to select the system's reaction to the loss of connection when the system is not armed (no supervision). The option allows to choose: sabotage (loud alarm) or failure.

In system standby mode (supervision), the loss of Aero connectivity is a sabotage of the system. Signaling after 100 s in accordance with the standard for grade 2.

Module status window (AP STATUS):

- **connected:** connection status with the OptimaGSM central office (is / not)
- **soft version:** firmware version on the APm Aero device
- **Uzas:** supply voltage at the module power supply terminals
- **Tamper:** monitoring the opening of the APm device housing (open / closed)
- **Walk Test:** information on switching on the Aero system test (detector) during system configuration (on / off)
- **Learning mode:** information on enabling learning mode for Aero devices (detectors, remote controls, modules) during system configuration (on / off)
- **Noise:** the value of the signal noise in the operating range of the Aero system, the limit value for the detection of jamming is -85 [dBm]

Two-way pilots configuration window:

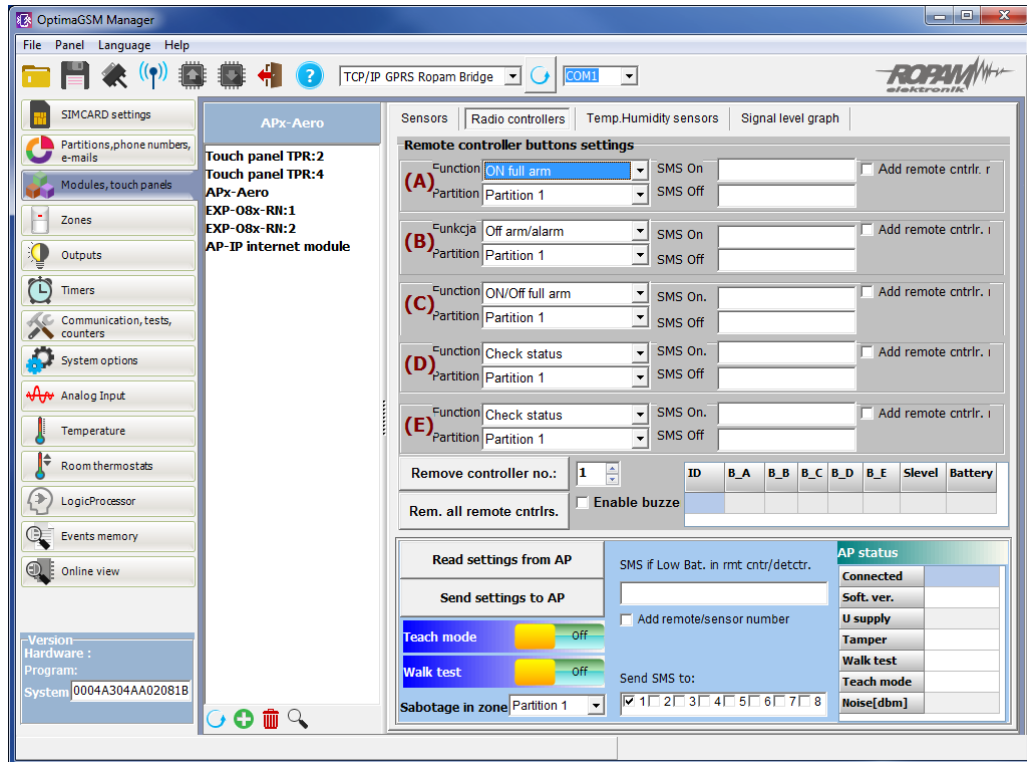

Configuration of channels (pilots).

- **Button (A) / (B) / (C) / (D) / (E):** select the action in the system for a particular channel. Options: **no function, on / off full standby, on / off night watch, armed on, night watch, off arming / alarm, loud panic, check status.**
- **SMS on / SMS off:** enter the message content for a particular event, e.g. for **on / off full armed mode**, you can enter SMS on / SMS off and for the **full armed system** you can enter: SMS on, etc.
- **Add remote control No.:** Selecting the function adds to the SMS content the pilot / detector number that generated the event.
- **Send an SMS to:** the matrix allows you to specify phone numbers to which SMS messages will be sent.
- **Delete the remote control no.** - removes from the Aero system the remote control with the selected number (1-16)
- **Delete all remote controls** - removes all preprogrammed remotes to Aero.

Pilot status window:

ID	B_A	B_B	B_C	B_D	B_E	Slevel	Battery

ID - number of the remote control programmed into the system (1-16),
 B_A - B_E - control lamp for pressing a button on the remote control (visible in the module programming mode),

Slevel - Aero communication level (range from -20 to -110 dBm),
Battery - battery status in Keyfob Aero (Ok, Poor).

Graph of the RSSI signal level.

A level histogram is available for each detector, distinguishing by color.

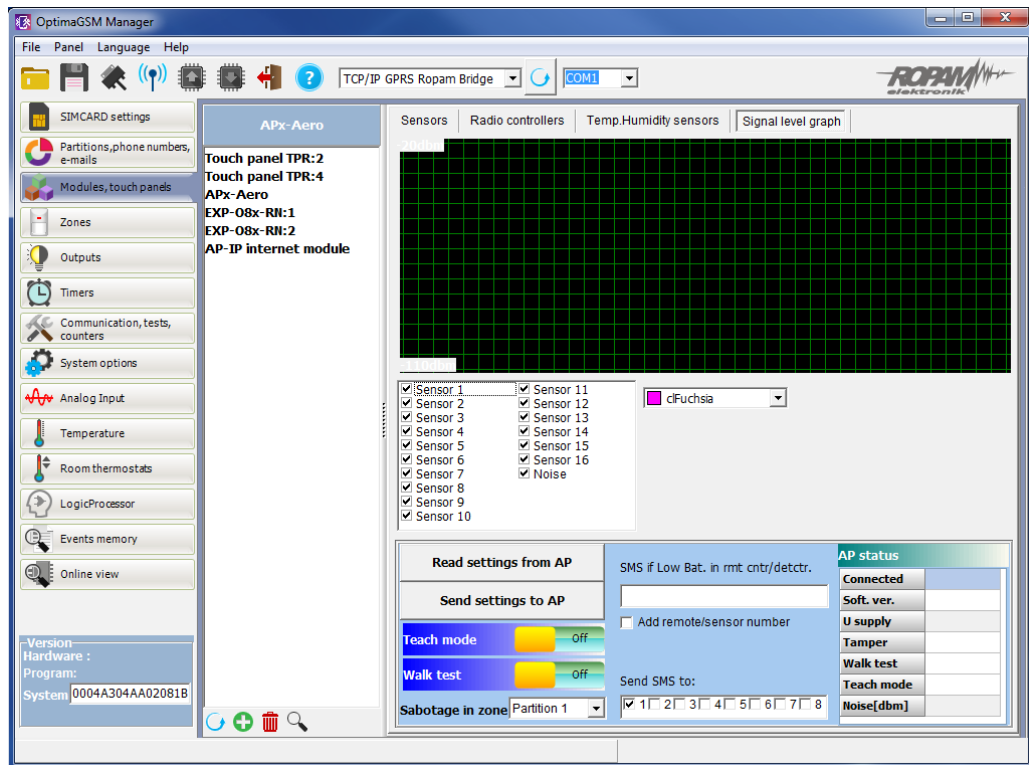

Technical parameters.

Parameter	Value
Power supply voltage	U= 9V÷14VDC (from the RopamNET bus or in accordance with the second class of insulation)
Power consumption	~ 25mA @ 12VDC
Aero communication in the ISM band	886.000 MHz ... 870,000 MHz sensitivity: -110 dBm, transmission power: up to + 10dBm, FSK modulation
System communication	EIA-485 - RopamNET system bus
Programming	from the level of the alarm control panel - system operation,
Working conditions	environmental class: II temp.: -10 ° C ... + 55 ° C RH: 20% ... 90%, no condensation
Connectors	AWG: 24-18, disjointed
Dimensions, weight.	80x80x25 (WxHxD, mm), antenna built into the PCB surface-mounted white ABS cabinet with optical signaling, ~ 70g

Version history.

Version	Date	Description
1.1	2014.03.01	First version
1.2	2015.01.02	The upgrade functionality has been added using the RS232TTL port (bootloader).
2.5	2015.12.07	Support for the OptimaGSM system has been added
3.2	2016.05.30	Added support: Keyfob-Aero, IO-Aero, OSD-Aero, 868 MHz band jamming detection, universal firmware for NeoGSM system (from v1.9), OptimaGSM (from v2.1), required: GSM Partner from v4.5 and OptimaGSM Manager from v1.8.

Keyfob-AERO

General description.

Properties.

- Aero system keyfob (Keyfob-Aero),
- compliance with SSWiN PN-EN 50131-1 step 2,
- bi-directional, encrypted (AES 128-bit) communication in the ISM 868 MHz band,
- high RF sensitivity up to -110 dBm,
- coverage above 200m in the open area,
- programming and diagnostics of the Aero remote control from the control panel level,
- full supervision and transfer of system statuses, presence control, link quality, battery status,
- the unique ID-Aero of each controller allows for proper operation within the range of another Aero system,
- optical and sound signaling of work,
- power supply: 3VDC, CR2032
- ABS housing white / black,
- cooperation with systems: NeoGSM (from v1.9), OptimaGSM (from 2.1), software version of APm required for pilots work > 3.0
- **The Aero controller or the EXP-I8 local expander can work on NeoGSM systems.**

Destiny.

Keyfob-Aero remote control is designed to work with Aero Ropam Elektronik wireless devices and through them to control the alarm system / building automation or control of selected system functions.

Warnings.

- For safety reasons, the device should only be configured by qualified installers.
- Before proceeding to configuration, read the understanding with the above instructions.

- Do not interfere with the construction or carry out independent repairs. • It is necessary to maintain possible antistatic protection measures to protect electronic circuits on PCBs against electrostatic discharge ESD.
- In order to meet the requirements of LVD and EMC, the following rules must be observed: power supply, installation, shielding - according to the application.

Pilot description.

Remote control versions.

Code	Description
Keyfob-Aero-W	System Aero bidirectional remote control (Keyfob-Aero), white ABS housing.
Keyfob-Aero-B	System Aero bidirectional remote control (Keyfob-Aero), black ABS housing.

Construction and description.



Keyfob-Aero pilot view

Description of the AERO remote control - LED RGB / buzzer interface.

1. The remote control unprogrammed blinks white when the button is pressed.
2. The remote control programmed blinks blue when the button is pressed.

Checking the zone status (RGB LED signaling, buzzer):

1. Unarmed zone, the diode blinks twice in green (buzzer 2x),
2. Armed zone, the diode will blink once in red (buzzer 1x),
3. Area armed night, the diode blinks once in violet (buzzer 1x),
4. Alarm / Tampering in the zone, the diode blinks ten times red (buzzer 10x tons high),
5. Not ready when arming in the zone, the diode blinks five times in red (buzzer 5x).

Transmission errors (RGB LED signaling, buzzer):

The pilot tries to transmit two times, then reports a transmission error. The diode will blink once red (buzzer 1x tons low).

Requirements, installation.**Basic requirements.**

Keyfob-Aero remote control should be used in conditions with normal air humidity (RH = 90% max. Without condensation) and temperature in the range of -10 ° C to + 55 ° C. When selecting the installation location of the receiver (APx-Aero), the following criteria should be followed:

- radio remote control range (attenuation of walls of a room: wood / gypsum - about 5% -20%, brick / ceramics: by 20% -50%, concrete / reinforced concrete: by 50% -80%, metal / steel: by 100%)
- assembly optimally centrally in relation to the expected range (radius) of pilots work,
- maintaining a safe distance from sources of possible interference (eg 230V / AC power buses - buildings, radio transmitters, etc.).
- driver availability for third parties and sabotage attempts,

Installing the controller.

1. Install the controller housing in a suitable place and enter the appropriate wiring through the cable glands.
2. Connect, in cooperation with the NeoGSM / OptimaGSM system, the RopamNET bus (3-wire):
A-A, B-B, GND-GND.
3. Connect (optional) the device to the controller outputs.
4. Start the system, turn on the controller's power supply.
5. Program the controller: for system operation from the central-control panel and the Partner GSM / OptimaGSM Manager application
6. Perform functional tests, check range.
7. After completing the installation, perform user training.

Comments:

It is necessary to keep possible antistatic protection measures to protect electronic circuits on PCBs against electrostatic discharge ESD.

Configuration.**Preparing the system for work.**

Depending on whether the remote control is programmed into the system or not - the procedure for configuring the remotes to operate with the selected Ropam Elektronik production system is presented below.

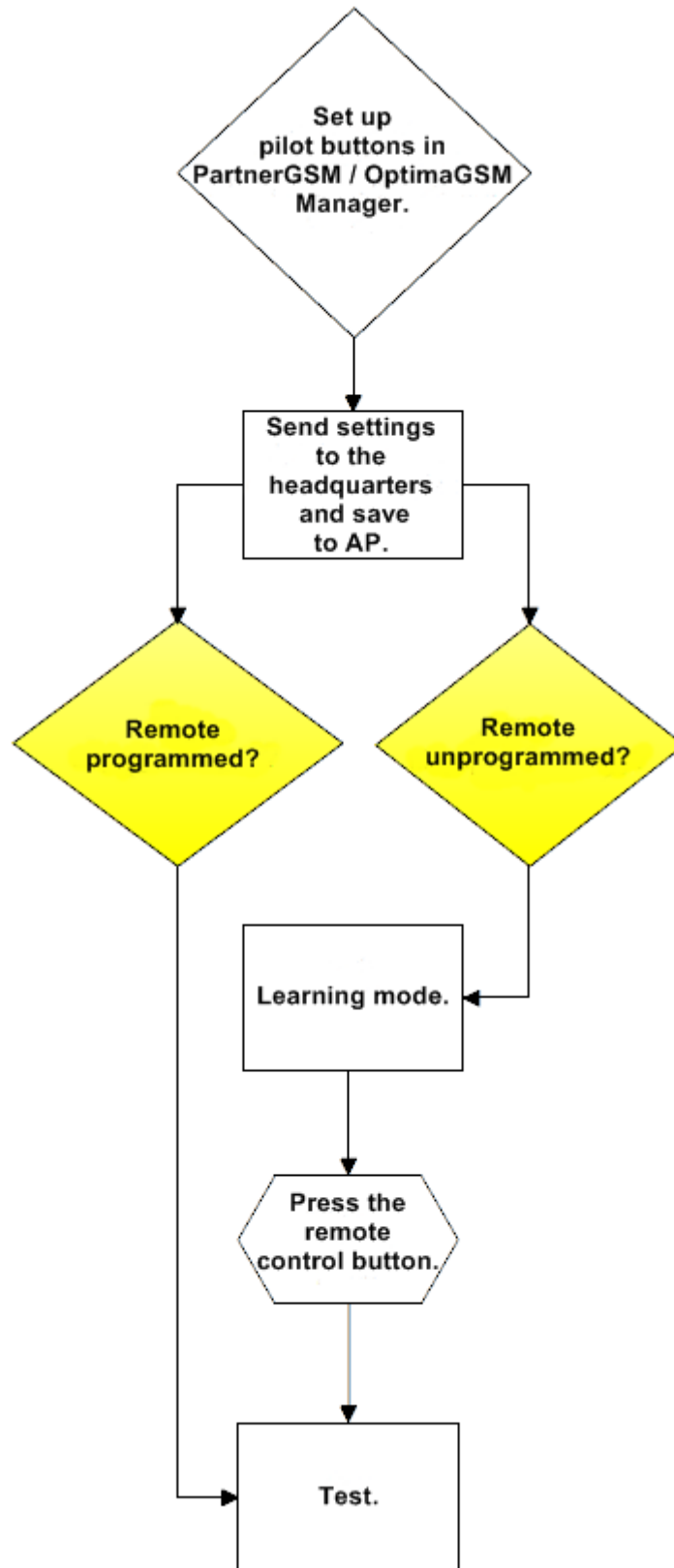

Procedure for adding a non-programmed remote to the system:

Learning mode in a dedicated software program: launches learning mode, adding new remote controls.

Procedure:

- enable the learning mode in the PartnerGSM / OptimaGSM Manager program
- press any button on the remote control, the corresponding message will be displayed in the program window (the LED blinks blue)
- test the operation of the remote control by settings in the program

Procedure of removing the programmed remote from the system:

- open the remote control housing, press the first two buttons (reset) simultaneously, insert the battery, the LED on the remote control will light up in white, the buzzer 1x,
- repeat point 1 for all pilots to be removed from the system.

Configuration: Partner GSM / OptimaGSM Manager._6

The remotes in operation system are configured from the level of the control panel.

Requirements:

- cooperation with the following systems: NeoGSM (from v1.9),
- cooperation with the following systems: OptimaGSM (from v2.1),
- Partner GSM program in a version dedicated to a given version of the exchange, version from Partner GSM 4.5
- OptimaGSM manager program: (version from v1.9)

OptimaGSM Manager: AP-Aero.

OptimaGSM program tab; APx-Aero.

The controller configuration and the RSSI radio signal level are available.

Tab AP-AERO, Remotes:

Remove the keyfob x: removes the indicated keyfob from the controller's memory, x; 1-16 (currently connected to AP).

Delete all keyfobs: the function deletes all keyfobs from the controller (currently connected to the AP).

Read settings from the AP: the function retrieves the settings from the AP.

Transfer settings to AP: the function sends settings to the AP.

Module status window (AP STATUS):

- **connected:** connection status with the OptimaGSM control panel (is / not),
- **soft version:** firmware version on the APm Aero device,
- **Uzas:** supply voltage at the module power supply terminals,
- **Tamper:** monitoring the opening of the APm device housing (open / closed),
- **Walk Test:** information on switching on the Aero system test (detector) during system configuration (on / off),
- **Learning mode:** information on enabling learning mode for Aero devices (detectors, remote controls, modules) during system configuration (on / off),

- **Noise:** the value of the signal noise in the operating range of the Aero system, the limit value for the detection of jamming is -85 [dBm],

Two-way pilots configuration window:

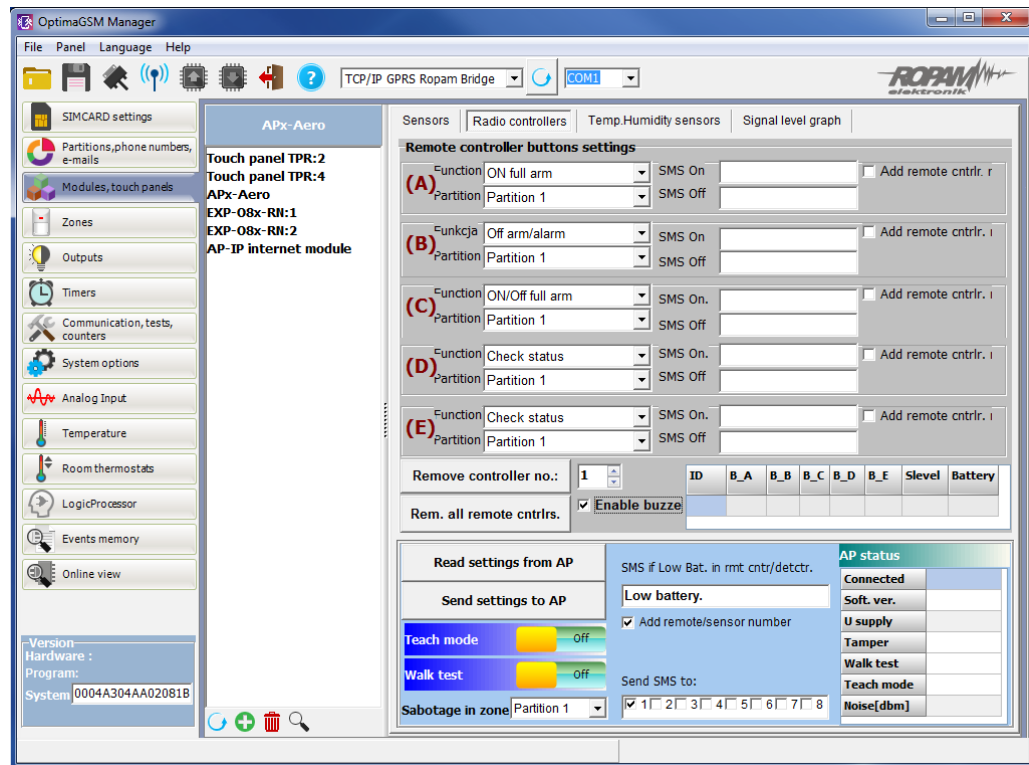

Configuration of channels (pilots).

- Button (A) / (B) / (C) / (D) / (E): select the action in the system for a particular channel.

Options:

no function,
est. / off. full waking,
est. / off. night watch,
on full armed mode,
on night watch,
Off. armed / alarm,
loud panic,
check status.

- **SMS on / SMS off:** enter the message content for a particular event, e.g. for start / stop. full armed mode, you can enter SMS on / SMS off. and for the full armed system you can enter: SMS on, etc.
- **Add remote control No.:** Selecting the function adds to the SMS content the pilot / detector number that generated the event.
- **Send an SMS to:** the matrix allows you to specify phone numbers to which SMS messages will be sent.

- **Delete the remote control no.:** removes from the Aero system the remote control with the selected number (1-16)
- **Delete all keyfobs:** - removes all pilots programmed into the Aero system.

Remote control status window:

ID	B_A	B_B	B_C	B_D	B_E	Slevel	Battery

ID - number of the remote control programmed into the system (1-16),
B_A - B_E - control lamp for pressing a button on the remote control (visible in the module programming mode),
Slevel - Aero communication level (range from -20 to -110 dBm),
Battery - battery status in Keyfob Aero (Ok, Poor).

Flags for the pilot in Logic Processor.

In the Logic Processor tab, you can select the flags corresponding to each of the remote control buttons and set the appropriate action for them as needed.

Flags in the LP for Keyfob-Aero:

- kb1,
- kb2,
- kb3,
- kb4,
- kb5

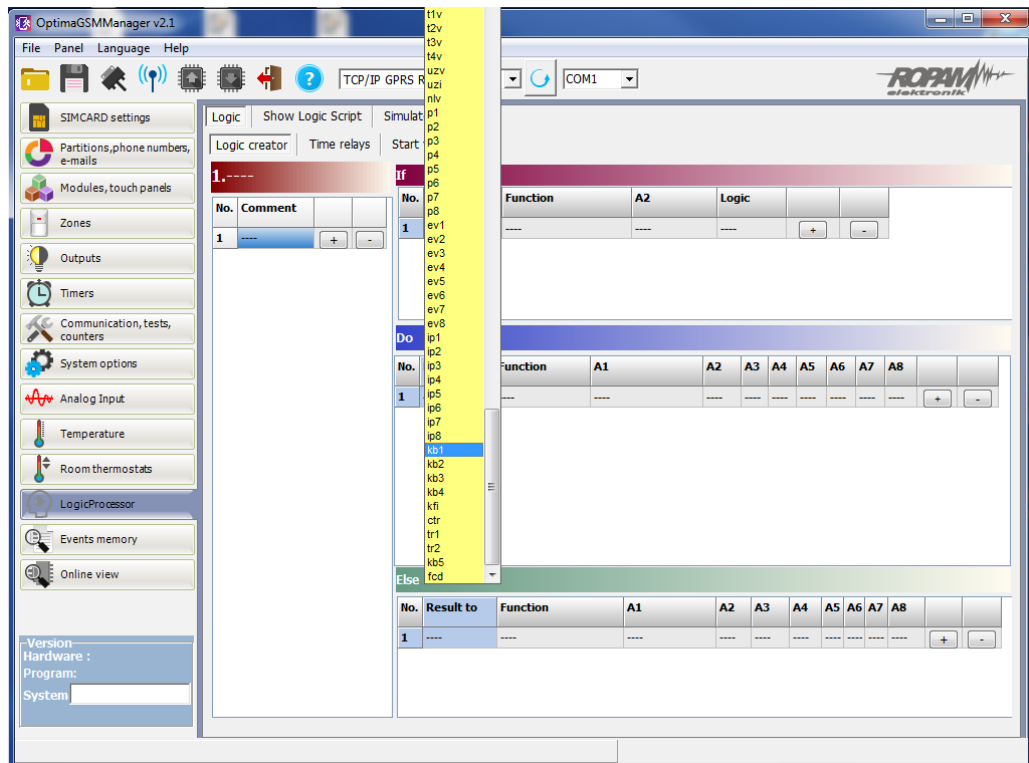

Technical parameters.

Parameter	Value
Power supply voltage	U= 3VDC (CR2032)
Work time	~ 2 years
Aero communication in the ISM band	886.000 MHz ... 870,000 MHz sensitivity: -110 dBm, transmission power: up to + 10dBm
Programming	from the level of the alarm control panel - system operation,
Working conditions	environmental class: II temp.:10°C ... + 55°C RH: 20% ... 90%, no condensation
Dimensions, weight.	69.85 x 34.80 x 17.53 (WxHxD, mm), antenna built into the PCB, ABS casing white / black with optical signaling, ~ 25g

Version history.

Version	Date	Description
3.1	2016.05.30	First version

WARNING:

The new firmware version (from v3.0) in the AP-Aero module only works with Aero devices with the firmware version from 3.x.

IO-AERO

General description.

Properties.

- system Aero wireless I / O module (IO-Aero),
- compliance with SSWiN PN-EN 50131-1 step 2,
- bi-directional, encrypted (AES 128-bit) communication in the ISM 868 MHz band,
- high RF sensitivity up to -110 dBm,
- automatic control of transmit power, up to + 10dBm, depending on strength (RSSI) and transmission quality (LQI),
- coverage above 200m in the open area,
- programming and diagnostics of Aero devices from the control panel level,
- full supervision and status transfer to Aero devices, presence control, link quality, battery status, presence of basic power supply,
- unique ID-Aero of each module allows for proper operation within the range of another Aero system,
- non-volatile configuration memory,
- optical work signaling,

- power supply: 3.6V / DC battery, or external 9-14VDC - white ABS surface-mounted housing - dimensions: 80x80x25 [mm],
- cooperation with the following systems: NeoGSM (from v1.9), OptimaGSM (from 2.1),
- **in NeoGSM systems, the Aero controller or the EXP-I8 local expander can be operated,**
- anti-sabotage protection.

Destiny.

The IO module of the Aero system is intended for wireless integration of wired devices (detectors, reed switches, etc.) with Ropam Elektronik systems via the wireless Aero system.

It allows to extend the functionality of the system with wireless devices in the absence of wired resources (cabling).

Warnings.

- For safety reasons, the device should only be configured by qualified installers.
- Before proceeding to configuration, read the understanding with the above instructions.
- Do not interfere with the construction or carry out independent repairs. • It is necessary to maintain possible antistatic protection measures to protect electronic circuits on PCBs against electrostatic discharge ESD.
- In order to meet the requirements of LVD and EMC, the following rules must be observed: power supply, installation, shielding - according to the application.

Description of the module.

Versions of the IO-Aero module.

Code	Description
IO-Aero	System Aero module, wireless communication, surface-mounted white ABS housing - dimensions: 80x80x25 [mm].

Construction and description.

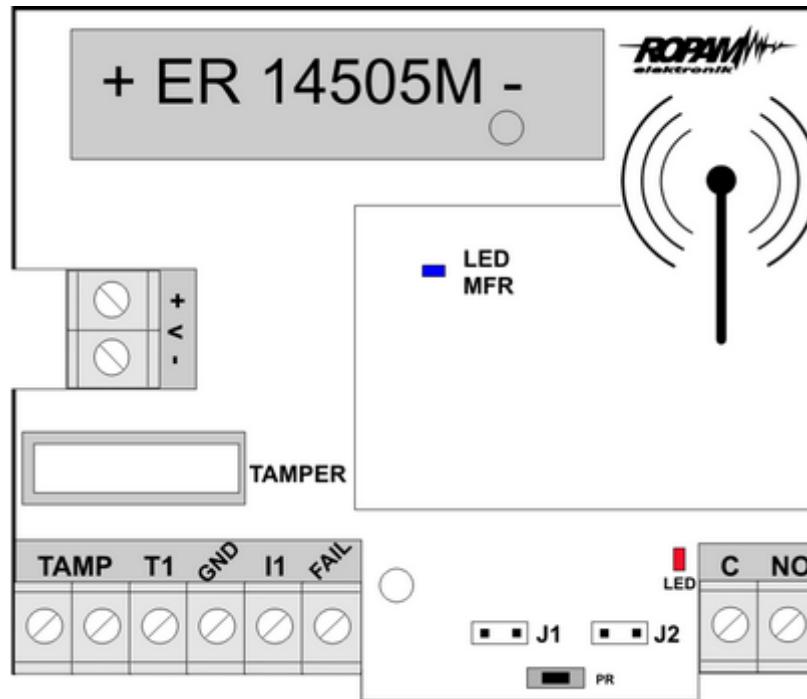

View of the IO-Aero module

Element (vice)	Description, function
+V-	DC power input: 9V ÷ 14 V / DC
GND	voltage terminal GND (0V) 'mass' power (GND)
TAMP	NC tamper output terminals
T1	external tamper input
I1	alarm input (for connecting an external device, type NC)
Fail	failure output (OC, 100mA @ 30VDC), signal output - GND, normal state - HiZ
C	COM relay output (0.5A / 125V AC1, 2A / 30V DC)
NO	NO relay output (0.5A / 125V AC1, 2A / 30V DC)

Assembly and installation.

Basic requirements.

The module should be installed in closed rooms with normal air humidity (RH = 90% max. without condensation) and temperature in the range of -10 ° C to + 55 ° C.

When choosing a mounting location, the following criteria should be followed:

- range of the radio controller (attenuation of the walls of the room: wood / gypsum- about 5% -20%, brick / ceramics: by 20% -50%, concrete / reinforced concrete: by 50% -80%, metal / steel: by 100%)

- assembly optimally centrally in relation to the anticipated range,
- module availability for third parties and sabotage attempts,
- maintaining a safe distance from sources of possible interference (eg 230V / AC power buses - buildings, radio transmitters, etc.).

Description and operation of the IO-Aero module.

The system wiring should be made using low-current cables.
Signals and power supply should be carried out in one cable.

The module checks the status:

- I1 input on the module's board,
- controls the OUT output according to the settings in the control panel, see table:

System NeoGSM:

Number of entry in the system	Number of output in the system
I13	O1
I14	O2
I15	O3
I16	O4
I17	O5
I18	O6
I19	O7
I20	O8

OptimaGSM system:

Number of entry in the system	Number of output in the system
According to the allocation of entries	

Installation and programming of the IO module.

1. Install the module housing in a suitable place and enter the appropriate wiring through the cable glands.
2. Connect the power wires to the terminals (wired supply).
3. Install the battery in accordance with the polarity (battery supply when there is no wired power available)
4. Connect devices to the module's I / O.
5. Start the system, turn on the controller's power supply.
6. Software module: for system operation from the control panel level and the Partner GSM / OptimaGSM Manager application,
7. Perform functional tests, check range.
8. After completing the installation, perform user training.

Module programming procedure:

1. Start the procedure of adding devices in the Aero controller (system work: Partner GSM / OptimaGSM Manager -> AP-Aero-> Enable learning mode, autonomous operation: AP-Aero programming menu).

2. Open the module and install the battery in the first module according to the polarity. The module after combining the connection with AP will generate a series of flashes (blue diode).
3. Repeat point 2 for all modules, IO modules receive system number according to the order of addition.
4. Check the status of the modules in the controller (RSSi, LQI), save the settings to the AP.

Comments:

It is necessary to keep possible antistatic protection measures to protect electronic circuits on PCBs against electrostatic discharge ESD.

Reset procedure for lips factory.

The reset procedure of the module to factory settings:

1. A module programmed into the AP controller (with a unique ID-Aero) can not be programmed into another AP, it requires a reset.
2. Reset procedure:
Remove the battery from the module → put the jumper on J1 pins → install the battery → remove the jumper within 10s.
The module will confirm the reset by a series of flashes with a blue LED 10x every 100ms
3. The module has ID-Aero reset (to factory), ready for new programming.

Configuration.**Configuration: Partner GSM / OptimaGSM Manager.**

The module during system operation is configured from the control panel level

Requirements:

- cooperation with the following systems: NeoGSM (from v1.9),
- cooperation with the following systems: OptimaGSM (from v2.1),
- Partner GSM program in a version dedicated to a given version of the exchange, version from Partner GSM 4.5
- OptimaGSM manager program: (version from v1.9)

OptimaGSM Manager: AP-Aero

OptimaGSM program tab; APx-Aero.

The controller configuration and the RSSI radio signal level are available.

Warning:

- the zone type should be configured in the entry tab, PIR AER detectors operate modes that are armed (supervision):
NORMAL, ORDINARY QUIET, DELAYED, LATE DELAY, COUNTER.

Device status window (detectors, IO modules):

ID	Type	Violator	Tamper	Sleve	RSSI	LQI	Vbat[V]	Connect	Sensitivity	Pulses	PetImmi
1.	PIR	Good	Good	-53	2	3,50	Active	4	PULSE 1	12kg	
2.	PIR	Good	Good	-55	11	3,50	Active	4	PULSE 1	12kg	
3.	IO module	Good	Good	-68	5	12,00	Active				
4.	PIR	Good	Good	-64	11	3,50	Active	4	PULSE 1	12kg	
5.	PIR	Weak	Good	-71	14	3,50	Active	4	PULSE 1	12kg	
6.	PIR	Good	Good	-63	9	3,50	Active	4	PULSE 1	12kg	
7.	PIR	Good	Good	-69	18	3,20	Active	4	PULSE 1	12kg	
8.	PIR	Weak	Good	-73	8	3,50	Active	4	PULSE 1	12kg	
9.	PIR	Weak	Good	-71	10	3,40	Active	4	PULSE 1	12kg	
10.	Smoke detec	Good	Good	-69	10	3,40	Active				

ID: Device number in the controller -> entry number in the system, e.g. ID 1-> I13 ... ID8-> I20.

Type: Aero device type.

Violation: state of the detector, motion detection.

Tamper: state of anti-sabotage circuit.

Sleve: communication level Aero (Excellent / Good / Weak), results from RSSI and LQI parameters.

RSSI: radio signal level (range -20 to -110 dBm).

Note: If there is another transmitter on the 868MHz band nearby, the RSSI reading (background) is lower, for the system it is a disturbance, increased ISM background.

LQI: radio transmission quality, lower value = better quality,

Vbat [V]: battery voltage in the detector, the new battery has 3.5-3.6V.

Note: the new battery achieves its nominal parameters only after about 24 hours of operation in the detector / module, this is due to the battery construction, very low power consumption by the detector, and ambient temperature.

Connection with AP: communication status with the detector / IO module.

Configuration of detectors / IO modules:

Learning mode: starts learning mode, adding new detectors / modules,

Procedure:

- open the detector / module and install the battery in the first detector or module in accordance with the polarity. The detector / module after combining the connection with the AP will generate two series of flashes (blue diode) with the device number in the AP (eg address 2 two series of flashes after two flashes),

- repeat point 2 for all detectors / modules, detectors / modules receive system number according to the order of addition,

- check the status of detectors / modules in the controller (RSSI, LQI), change the configuration for individual detectors / modules, save settings to detectors / modules from the AP level.

Remove detector no. X: removes the selected detector or module from the controller's memory, x; 1-16 (currently connected to AP).

Remove all detectors: the function removes all detectors / modules from the controller (currently connected to the AP).

Read settings from AP: function gets settings from detectors / modules.

Send settings to the AP module: the function sends settings to all detectors / modules.

Wireless communication interval: the detector / module status interval has three intervals: 30/60/90 s (60s by default). For maximum battery life, select the interval of 90 seconds.

The control interval affects the time after which the AP command will be sent to the detector / module including: armed mode (supervision).

All alarms, sabotages are sent without delay to the AP controller.

The detector / module automatically controls the transmission power to obtain effective communication and maximum battery life.

Comments:

If the detector / transmitter is not connected to the AP (eg after switching off the AP power supply), the detector / module goes into the power saving state.

Subsequent attempts to connect and synchronize take place every 10 minutes. The blue LED indicates a series of 10x flashes every 10 minutes.

Loss of wireless communication (disarmed): the function allows you to select the system's reaction to the loss of connection when the system is not armed (no supervision). The option allows to choose: sabotage (loud alarm) or failure.

In system standby mode (supervision), the loss of Aero connectivity is a sabotage of the system. Signaling after 100 s in accordance with the standard for grade 2.

Module status window (AP STATUS):

- **connected:** connection status with the OptimaGSM central office (is / not)

- **soft version:** firmware version on the APm Aero device

- **Uzas:** supply voltage at the module power supply terminals

- **Tamper:** monitoring the opening of the APm device housing (open / closed)

- **Walk Test:** information on switching on the Aero system test (detector) during system configuration (on / off)

- **Learning mode:** information on enabling learning mode for Aero devices (detectors, remote controls, modules) during system configuration (on / off)

- **Noise:** the value of the signal noise in the operating range of the Aero system, the limit value for the detection of jamming is -85 [dBm]

System maintenance.

The device does not require any special maintenance. During periodic technical inspections, it is necessary to check the condition of screw joints, emergency power supply status, clean the PCB with compressed air. The system should be periodically tested for proper operation and communication.

Technical parameters.

Parameter	Value
Power supply voltage	U = 9V-14V DC basic / U = 3.6VDC, battery ER14505M
Power consumption	~ 2mA@12VDC / ~ 0,2mA @3,6VDC
Aero communication in the ISM band	886.000 MHz ... 870,000 MHz sensitivity: -110 dBm, transmission power: up to + 10dBm, FSK modulation
System communication	RopamNET system bus
Programming	from the level of the alarm control panel - system operation,
Working conditions	environmental class: II temp.: -10 ° C ... + 55 ° C RH: 20% ... 90%, no condensation
Connectors	AWG: 24-18, disjointed
Dimensions, weight.	80x80x25 (WxHxD, mm), antenna built into the PCB surface-mounted ABS cabinet white with optical signaling, ~ 70g

Version history.

Version	Date	Description
3.1	2016.06.03	First version.

WARNING:

The new firmware version (from v3.0) in the AP-Aero module only works with Aero devices with the firmware version from 3.x.

TPR-4

General description.

Properties

TPR-4 series touch panels are touch manipulators that allow you to fully use the resources of alarm systems and building automation based on Ropam Elektronik products.

A modern design based on capacitive touch technology and advanced communication algorithms allow the user to easily view and control the system status.

The function of a random keyboard displayed on the screen enables variable keystrokes whenever there is a need to log in to the system / verification of settings, which increases the safety of the system.

The flexibly configurable panel screen menu allows you to adjust the functionality of the screen and system according to the user's needs (the icon configuration function on the screens).

The SD card slot provides the ability to write events from the system (temperature, analog input AI logs) and allows you to save the file with the building plan and then view current events (eg violation of inputs) on this plan as well as displaying photos from the SD card in the screen saver mode screen.

The panel is equipped with 2 additional inputs which increases the functionality and ergonomics of the system (inputs parametrized identically as in the system: NO, NC, EOL, 2EOL NO, 2EOL NC).

The intuitive user menu and extensive features of the installer fully meet the needs of current alarm systems and home automation.

The firmware update function in the panel through the micro USB connector makes it easy to upload new versions of the panel software to the device.

Destiny

TPR-4 series touch panels and other additional devices are an ideal solution for residential buildings and small commercial facilities. Modern design, proven technology of the touch panel with a spectacular color LCD display is ideal for composing in most interiors and rooms. The intuitive and clear interface makes the control of the alarm system / home automation has never been as easy as with the TPR-4 series touch panels. Touch panel in combination with the series control panels: OPTIMAGSM allows you to build a fully functional alarm system / home automation.

Flexible functions also allow for use in systems that use binary signal control, temperature, humidity, visual verification is required and information transfer is based on SMS, VOICE, MMS, e-mail.

Warnings

Ropam Elektronik devices are part of a full alarm system, whose effectiveness depends on the quality and technical condition of all devices (detectors, signaling devices), cabling, etc. included in the system. The user is obliged to periodically test the operation of the alarm system. It should be checked whether the control panel reacts to the violation of individual detectors (PIR, reed switches, etc.) whether the sirens (external and internal) and notifications are active. The detailed method of system control is determined by the installer that the system has designed. Periodic system maintenance is recommended (with device status check, back-up power supply, system operation, messaging, etc.). Ropam Elektronik is not responsible for the correct operation of operators and GSM network infrastructure used for notification of alarm states and remote control. With this in mind, we recommend using such services and subscriptions available on the market, which guarantee correct operation (minimizing the human factor, eg blocked outgoing calls due to lack of funds on the account), allow for full configuration of GSM bus occupancy (eg disabling advertising services, not available in pre-paid services). In addition, it should be noted that services guaranteed by GSM operators are voice transmission services (VOICE) and not SMSs, that is why important information should be transmitted through voice calls and possibly accurate identification of the event takes place in an SMS (eg VOICE + SMS, CLIP + SMS).

Description of the touch panel.

Basic properties of the TPR-4 touch panel:

- 4.3 "TFT LCD color display, 16.7 million. colors
- "Touch Panel" touch panel, without mechanical contacts
- interactive graphic menus with pictograms (icons)
- the function of a random numeric keypad layout
- configurable panel menu (icons)
- text hints for given functions
- intuitive: system control and control
- control of the control panel outputs
- fast control of the TPR-4 relay output
- system status LEDs
- a bar of additional information about the system status

- displaying information from LogicProcessor on the main screen
- acoustic signaling
- screen saver with calendar and clock function
- two alarm inputs
- RS485 bus for system communication
- local USBmicro port for updating the panel firmware
- software upgrade function
- Aesthetic and solid housing in white or black
- tamper protection of the housing
- detachable terminal strips
- cooperation with headquarters: OptimaGSM

Construction of the TPR-4 touch panel

The TPR-4 touch panel in a surface-mounted housing consists of:

- polycarbonate base, for fixing the PCB (fastened by screws (4) to the base),
- PCB with TFT display, anti-tamper switches, connectors and electronic components (fastened by screws (4) to the base),
- external polycarbonate panel, closing the TPR-4 housing (mounted to the base by screws on the side of the housing (4),
- frame masking fastening with screws,

Description of connectors and elements.

The touch panel has two terminal strips.

Connector / element	Description / Function
NC	relay contact normally closed (set when switching to the ON position)
C	relay contact common for NC and NO
NO	relay contact normally open (short-circuiting when switching to the ON position)
I2	alarm input in the panel, the other terminal GND,
I1	alarm input in the panel, the other terminal GND,
A	RS 485 system bus connector, connection principle A-A
B	RS 485 system bus connector, B-B connection principle
GND	"panel" ground terminal, common for power supply and panel inputs.
+12V	DC power supply input panel, second GND terminal
USB micro	USB port for connecting the service computer, used for updating the firmware (firmware) in the touch panel (USB A - USB B micro cable required)
JT1 jumper	JT1 fitted = terminating resistor switched on in the RS485 bus JT1 removed = terminating resistor disconnected from the RS485 bus
PR jumper	Assumed = entering the panel update mode, buzzer on - continuous signal

	Off = normal operation
SD card slot	<p>slot for microSD card (SD / SDHC) mounting required for the function:</p> <ul style="list-style-type: none"> - building plan (synoptic board), 'plan.bmp' (service), - the ability to upload up to 4 plans <p>file location: SD / plan1.bmp, file type: BMP, size: 480x272px or smaller in proportions, number of colors: 256 (8bit) or 16 mln. (24bit)</p> <ul style="list-style-type: none"> - digital photo frame, 100 photos maximum, photo display time 10 sec., sequence: file date order (oldest = first) <p>file location: SD card / pics, file type: BMP, JPG, size: 480x272px or smaller in proportions, number of colors: 256 (8bit) or 16 mln. (24bit)</p> <ul style="list-style-type: none"> - registration of the temperature history (automatically), for each day a file with data in the format rr_mm_dd.txt is created. for further data processing

View and dimensioning of the panel.

On the back of the device there is a hole, which can be used to feed power and signal wires to the panel. The aesthetic design, easy-to-install housing and ergonomic connections make the installation and operation of the device easy and uncomplicated operation.

Dimensioning and panel view:

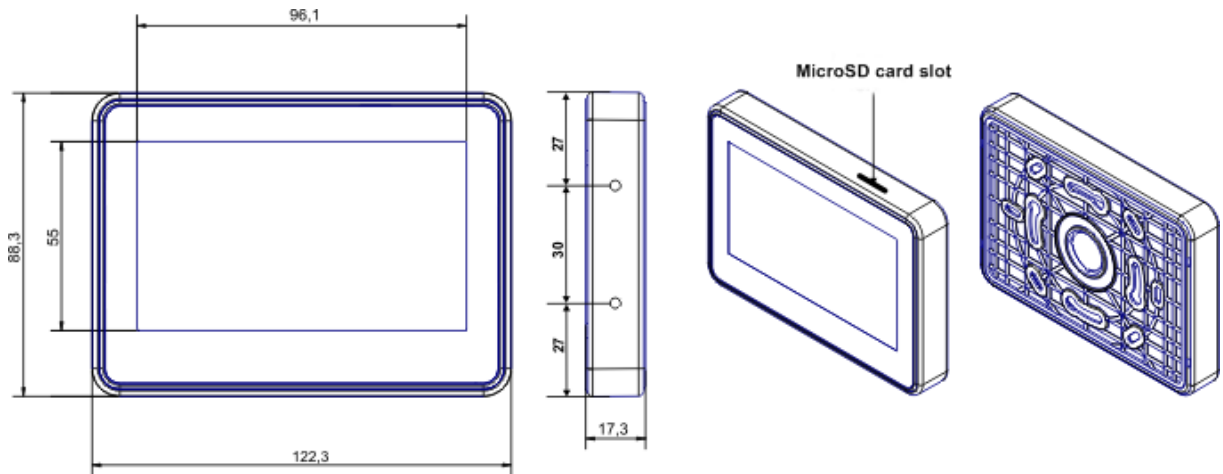

Installation and commissioning.

Basic requirements.

The system built on the basis of TPR-4 series panels and other required elements are intended for assembly by a qualified installer, holding appropriate (required and necessary for a given country) permissions and licenses to connect (interfere) 230V / AC installations and low-voltage installations. The devices should be installed in closed rooms with normal air humidity (RH = 20% - 90% max. Without condensation) and temperature in the range -10 ° C ... + 55 ° C. Before starting the installation, a load balance of the power supply should be prepared. Since the system power supply is

designed for continuous operation, it does not have a power switch, therefore proper overload protection should be provided in the power supply circuit. You should also inform the user about the method of disconnecting the power supply from the mains voltage (usually by separating and marking the appropriate fuse in the fuse box). The electrical installation should be made in accordance with applicable standards and regulations.

System cabling.

The system wiring should be made with the use of low-current cables. In addition, it should be in accordance with the rules and standards, in particular, this applies to the selection of the type and cross-section of cables, the distance from the 230V / AC wiring, etc.

The RS485 system bus should be made using:

- UTP, STP, FTP so-called twisted pair copper
- YTSKY (optional) telecommunications (pairing) cables,

Signals and power supply should be run in one cable. If shielded cables are used, the screen should be connected point-by-point to the PE circuit in the control panel housing.

The remaining connections should be made in accordance with the device manufacturer's instructions, and if there are no such cables, the following cables can be used:

- YTDY, YTLZ,
- UTP, STP, FTP,
- YTSKY,
- other low-current, compliant with regulations and standards.

The system bus connection can be made according to the scheme, with the total length of the RS485 bus should be maximum 1200 m:

TP1 ÷ TP4	OptimaGSM
A	A
B	B
GND	GND
+KB	+KB

- serial (JT1 jumper found only in TP4 and headquarters)

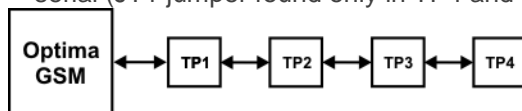

- in series (JT1 jumper found only in TP1 and TP4)

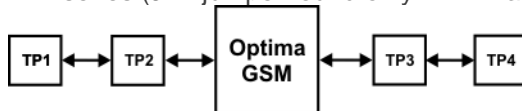

OptimaGSM	TP1 ÷ TP4
A	A
B	B

OptimaGSM	TP1 ÷ TP4
GND	GND
+KB	+KB

Recommended minimum cross sections for UTP 4x2x0.5mm cable (0.5mm - \varnothing conductor), with one TPR-4 connection. The minimum supply voltage at the terminals of a given TP can not be lower than 9V / DC (ie at a minimum battery voltage of 9.5V-10.0V, the drop on the power supply wires can not be greater than 0.5V).

Signal	to 150m.	to 300m.
A	2x0.5 (1 pair)	2x0,5 (1 pair)
B		
GND	1x0,5	2x0,5 (1 pair)
+KB	1x0,5	2x0,5 (1 pair)

Panel connection

The rear view of the panel with PCBs and connectors.

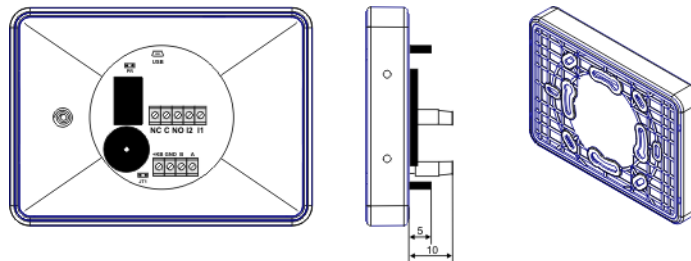



Installation and start-up procedure TPR-4

1. Perform complete wiring: signaling and power supply.
2. Remove the TPR-4 touch panel (e):
 - remove the frame covering the sides of the housing (without tools, manual disassembly)
 - remove the rear part of the housing
 - screw the back of the housing to a properly mounted can in the ground
(The mounting surface must be smooth, as the deformation of the base will result in a lack of fitting with the external panel.) Attempting to forcefully fit the base and outer panel may damage the TFT display.)
3. Remove the terminal blocks from the PCB

4. Connect the required signals to the panel terminal blocks.
5. If the TPR-4 panel is located at the end of the line at the serial connection or the panels are connected in a star, a JT1 jumper (terminating resistor RS485 bus) must be installed.
6. Assemble the TPR-4 panel (e) in reverse order of point 2.
7. Perform the remaining activities and connections in the system (GSM panel, detectors, sirens).
8. Turn on the system power supply (230V / AC).

NOTE: if TPR-4 (2-4) panels are installed in the system, the first start-up should be performed without connected RS485 bus. After switching on the power supply, change the address of the selected panel on TP2, TP3, TP4, confirm the change (service menu) and turn off the power supply. Then connect the RS485 bus to the panels and re-connect the system power supply.

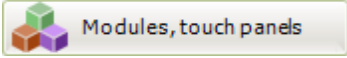
9. Perform the remaining steps in the system, eg connect the battery.
10. Start the service computer and the OptimaGSM Manager application.
11. Connect the RS232-MGSM or USB-MGSM cable to the port on the computer and to the RS-TTL socket on the control panel board.

12. Configure the system and panel (s), identify the modules in the system (icon  in the tab , save the configuration to the control panel ).
13. Perform tests and functional tests (without on-line mode !!).
14. Disconnect the cable from the RS TTL jack and perform the remaining required operations.
15. Perform final tests and functional tests, user training.

NOTE: The TPR-4 is based on a capacitive TFT display. Avoid flooding, contact of the display with water!

Configuration of TPR-4 touch panels.

The programming and configuration of the touch panel can be done:

- from the service menu level (locally, each TPR-4 touch panel independently - only selected functions)
- from the OptimaGSM Manager program (locally or remotely - RopamBridge, Local server, AP-IP)

Main menu of the TPR-4 touch panel (default setting of icons):



TPR-4 configuration: user menu

User screen - OptimaGSM system

Window view with user settings for the TPR-4 panel:

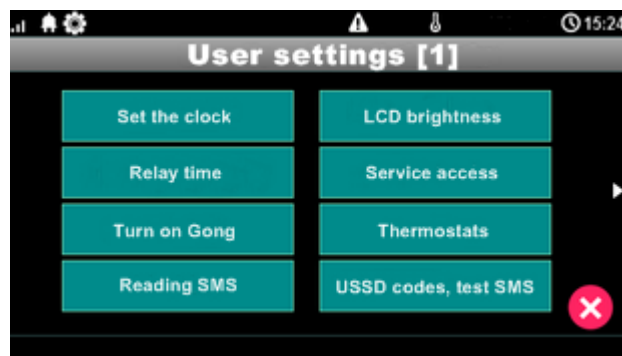

Set the clock

Option to set time and date in the system.

Relay time

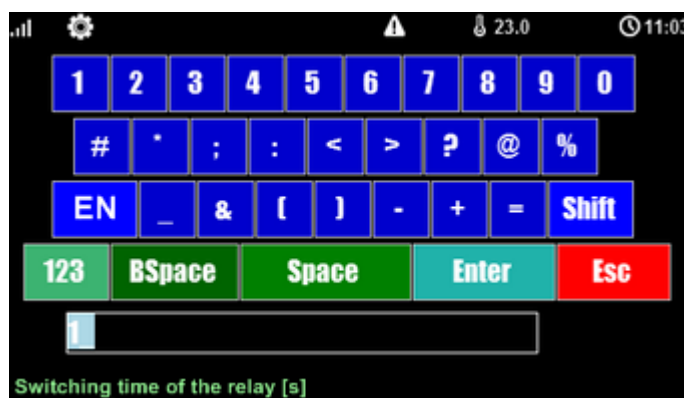

* Setting: bistable operation, time 0s. causes the relay to operate from being switched on to being turned off by the icon on the touch panel.

Turn on Gong

Gong activation in the TPR panel.

Reading an SMS

Reading SMS sent to the system.

Brightness of the screensaver

Adjust the brightness of the screen saver for the digital photo frame (when the current SD card with photos) or the brightness of the clock with a date stamp on the display screen.

The brightness changes can be made with the help of the "slide" gesture - the finger is moved along the scale of brightness. The brightness of the display is updated on a regular basis.

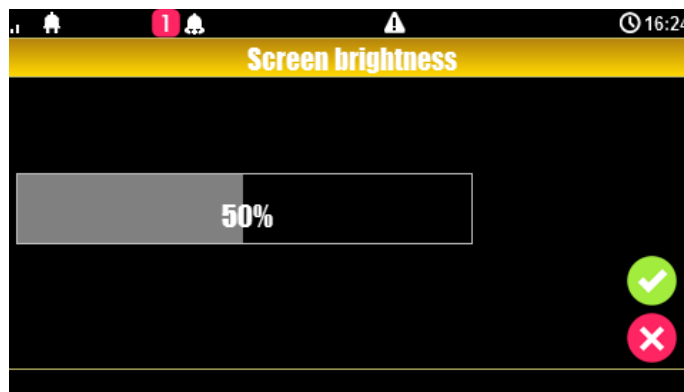

Service access

Activation of access to service functions in the TPR panel.

Access to the service functions is possible for 8h or until the next restart of the control panel.

After that, if necessary, activate the service mode again.

Thermostats

Temperature settings for individual thermostats - temperature sensors (4 independent in the OptimaGSM system).

The upper temperature values are Tx (a)

The lower temperatures are Tx (b)

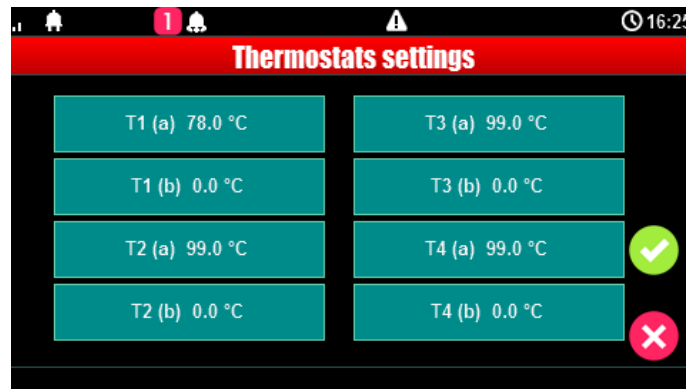

After selecting a window with the temperature settings of a given sensor, the temperature settings window opens:

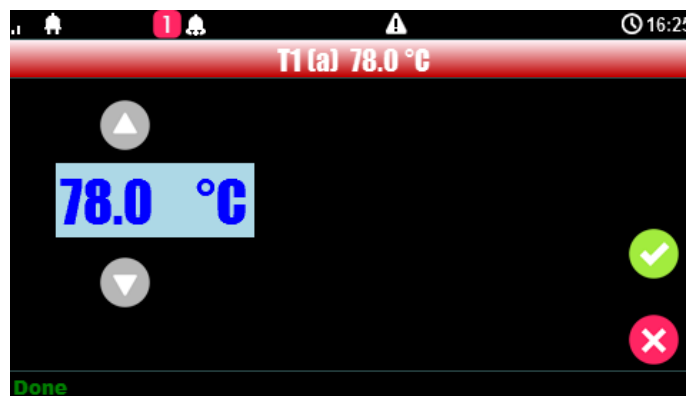

Room thermostats

The function allows setting two independent thermostats based on temperature sensors connected to the OptimaGSM system (1-4).

Room thermostats allow you to control the climate in the room, listening to a set time and temperature schedule.

This functionality also allows significant energy savings in the building (no space heating during absence of household members, switching on the heating before returning to the rooms, room ventilation function ensures access of fresh air to the building according to a specified schedule).

Thermostat settings window - OptimaGSM Manager:

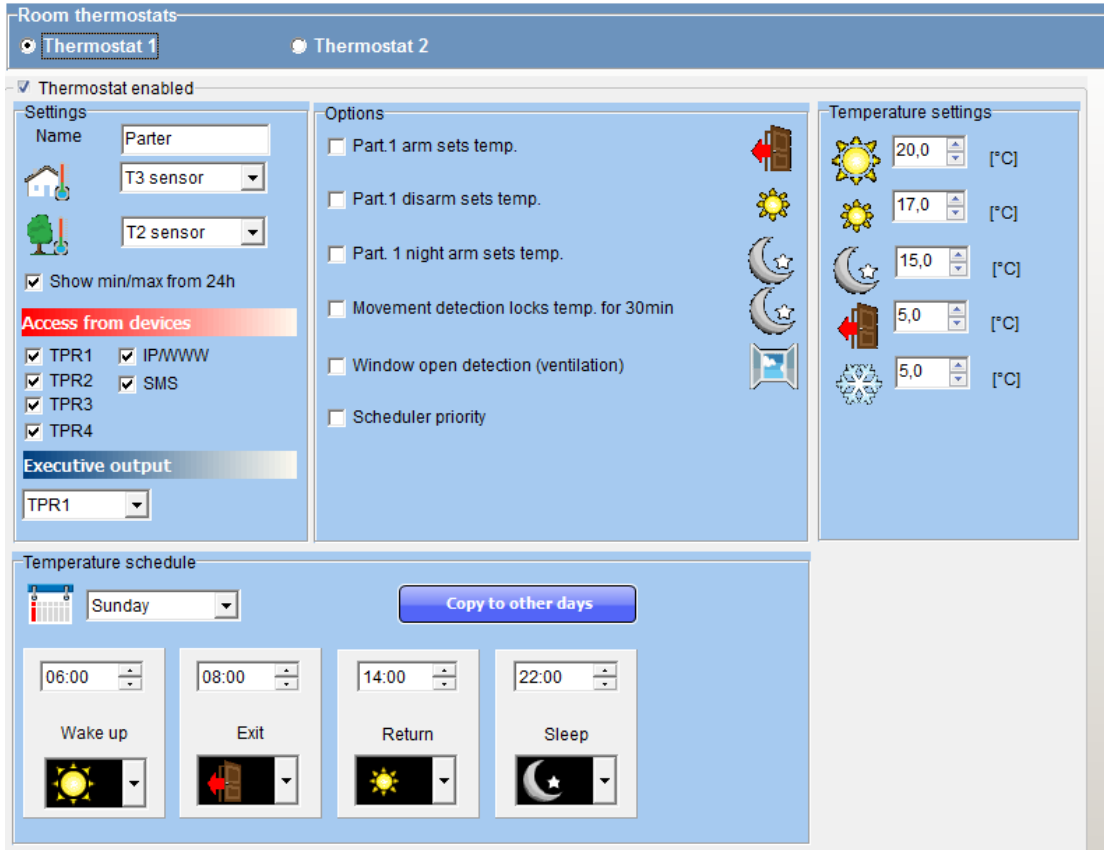





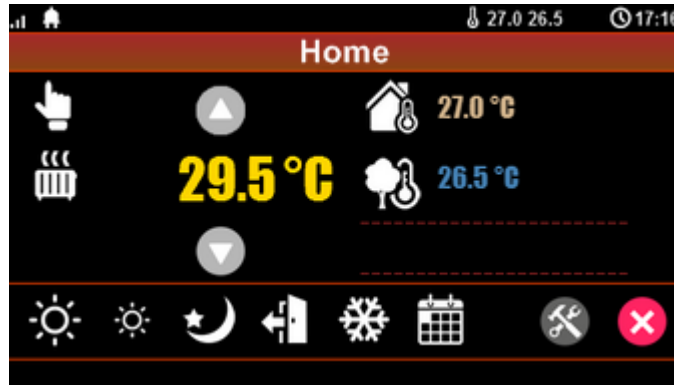







- "Show daily values min./max." displays on the touch panel with icons information about the maximum and minimum temperature measured over the last 24 hours.
- the "Window opening detection (weathering)" function is used to save energy when a gradient of temperature drop above 2 ° C is detected. The function switches off the heating mode for 30 minutes. During this function, it is possible to manually activate any of the thermostat programs.
- the "Schedule priority" function (when enabled) allows you to restore the thermostat to automatic mode after manual activation of any of the functions (eg Wake, Exit, Return, etc.).

Thermostat view from the TPR-4 panel:

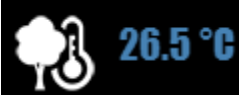

Explanation of the meaning of thermostat icons:

Icon	Explanation
	Entering the manual temperature control mode. It is also attached after sending an SMS saying "Heating"
	Heating mode - higher temperature.
	Information: Heating mode included
	Heating mode - reduced temperature.
	Night mode, lower room temperature, energy saving.
	Calendar mode, automatic - according to the settings in OptimaGSM Manager.

	<p>The exit mode from the building, by default: lowering the temperature to save energy.</p>
	<p>Anti-freezing mode. It is used to ensure the minimum temperature in buildings in the absence of tenants. Prevents refrigerant from freezing in radiators.</p>
	<p>Outside temperature indicator. (connection of the TSR sensor to one of the 4 inputs in the OptimaGSM control panel is required).</p>
	<p>Internal temperature indicator. (connection of the TSR sensor to one of the 4 inputs in the OptimaGSM control panel)</p>
	<p>Histogram of switching on the relay in the TPR-4 panel responsible for the heating control functions in the room.</p>
	<p>Thermostat settings icon (temperature profiles, weekly program). Changing the settings changes the temperature and calendar parameters according to the settings and saves these settings in the control panel.</p>

Thermostat settings from the TPR-4 panel:

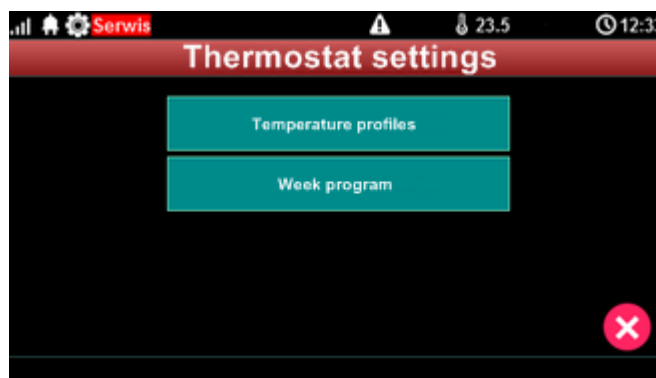

Menu for setting temperature profiles:

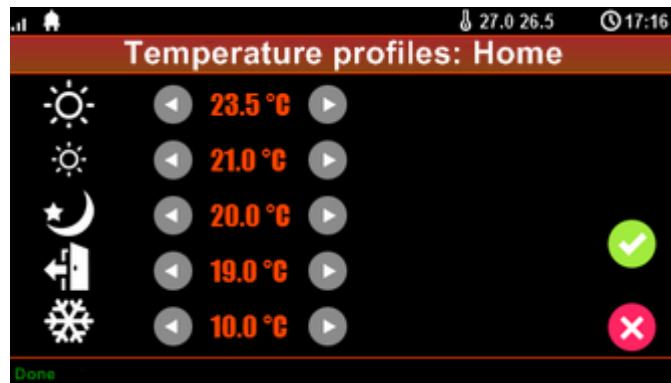

Calendar settings menu for room thermostat:



Timers 1-4

Available timing modes for the OptimaGSM system are:

- constant
- daily
- weekly
- monthly
- one year

Timer settings for the system - window view in the OptimaGSM Manager program:

No.	State	Year	Month	Day	Time	Week day		
1	1 ON				22:01:00		+	-
2	0 OFF				07:00:00		+	-

Timer type

Yearly Daily
 Monthly Permanent
 Weekly Off

The TPR-4 touch panel can only ONLY set daily and weekly timers !!

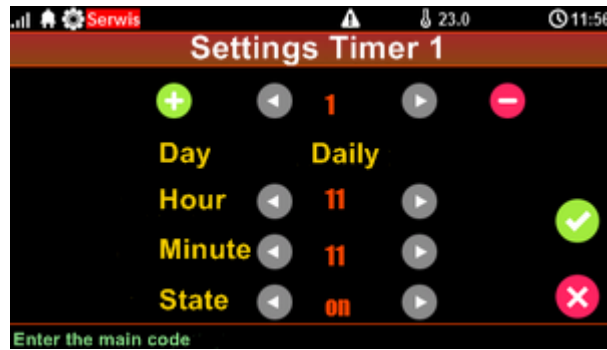

If there is a timer other than a daily or weekly timer in the system, its editing is possible ONLY with the OptimaGSM Manager utility.

If you try to edit such a timer using the TPR-4 panel, the following message will be displayed:



USSD codes, test SMS

Convenience enabling access to the system test functions from the touch panel level in OptimaGSM systems.

Testing system operation using USSD commands and sending test SMSs from the touch panel level without the need to access the system using the OptimaGSM Manager utility.

Entering the USSD code

After pressing, the screen for entering the USSD code will appear.

Send the USSD code to the GSM network

The function allows you to verify the funds available on your prepaid account, top-up and other account management functions using USSD codes.

Send a test SMS

Sends an SMS entered using the keypad on the touch panel to the first user on the list of numbers in the system.

The function gives the possibility to test the operation of SMS commands in the system.

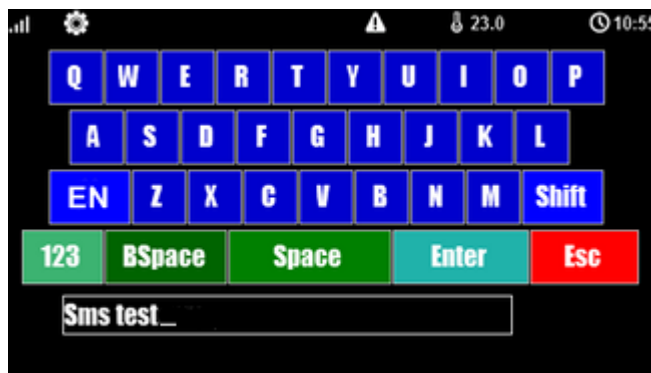

Internet module

Configuration window of the AP-IP module. It allows you to read the module data:

- network status
- sending an SSID
- sending a WPA encryption key
- module restart.

The SSID key: allows you to give the system name broadcast for WiFi devices (in the name you must not use the space character!).

WPA key: allows you to assign a WPA encryption key for wireless access to a system equipped with an AP-IP module.

Restart button of the module: in the case when the AP-IP module does not respond to queries for too long, there are problems with the remote connection set-up or problems with reading the network status, you can use the restart function of the AP-IP module (usually the reset takes about 1 min).

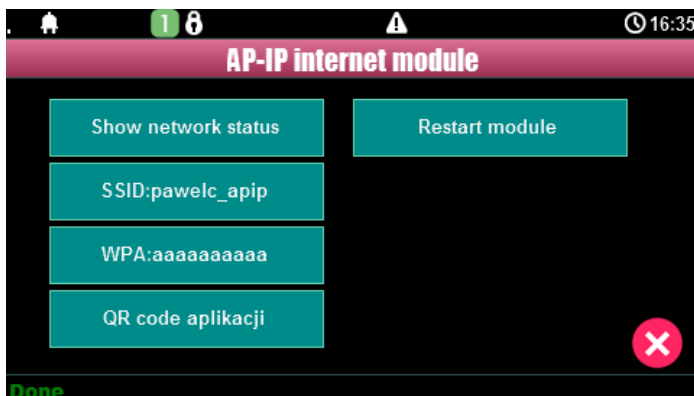

Show network status

Network status: read LAN and WiFi configuration data from the AP-IP module for the purposes of a remote connection with the system or diagnosis of problems with remote connection via TCP / IP.

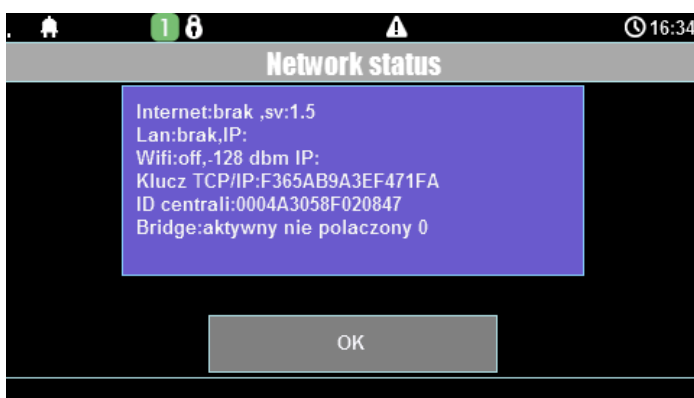

SSID:

The name of the WiFi network to which the AP-IP module is to login.

WPA:

Security key for WiFi networks.

Module restart

The AP-IP module restart option, required when the module does not respond too long.

Remote programming

Function that provides the ability to remotely program the system via a remote connection to a computer (via GPRS, TCP / IP).

TPR-4 configuration: service menu.

Activation of access to service functions takes place after activating service access in the user menu - button: "Service access".



In order to enter the access settings for the installer, press , then the "service" button. **Enter the service code and confirm 'enter' (default service code = 123B).** After this operation, configuration options are available.





Confirmation of changes takes place via the button:  and the output without saving changes:



ATTENTION: In service mode, the system does not support current events from zones, tamper alarms, etc. The service mode is indicated by the blinking of the red and yellow LEDs.

For other windows / keyboards:

Window type / Keyboard	Confirmation of the function	Exit the function
Numerical	#	*
Full	ENTER	ESC
Grafic		

Window view with service settings for the TPR-4 panel:

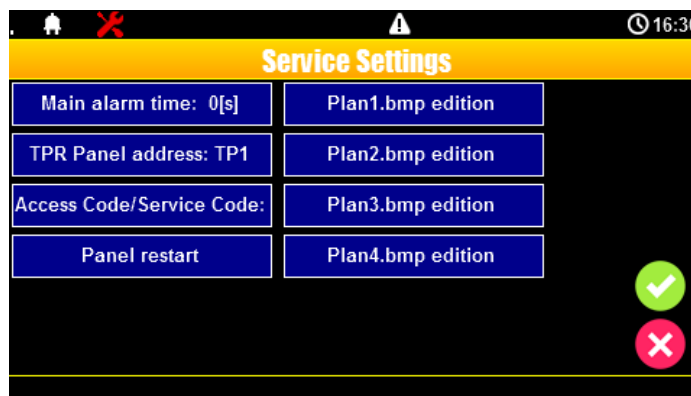

Settings 1.

- **Loud alarm time** - defines the time of acoustic alarm signaling in a given touch panel. Setting range: 0-9999 [s].
- **Address of keyboard** -TP1 to TP4 (TP1 factory, if more than one TP panel will work in the system, the system should be started according to the procedure and TP TP-TP4 address should be changed in the selected TP).
- **Password / access code / service code: available change of service code (also communication password with OptimaGSM Manager). The password should consist of four characters (digits, letters: large or small).**
- **Restart of the control panel** - TPR-4 allows the system to be restarted from the touch panel level. The function is useful after making changes to the system.
- **Plan edition:** the window allows you to place detectors on the building plan. The detectors are located (touch locations) in the order: I1, I2..Ix.
>: skip the given entry number
OK: accept the placement
X: output without acceptance

Location of the file with the building plan: SD / plan.bmp, file type: BMP, size: 480x272px or smaller in proportions, number of colors: 256 (8bit) or 16 mln. (24bit), in addition, the touch panel version information is displayed.

WARNING:

- all names of up to 20 characters,
- allowed Polish fonts,
- names are stored in the memory of a given TP

TPR-4 configuration: OptimaGSM Manager.

The OptimaGSM Manager program is designed to work on PCs with the operating system WINDOWS XP / VISTA / 7/8/10. Communication between GSM Partner and Ropam devices is via: RS232 or USB port using communication cables with built-in RS232-RS232-TTL or USB-RS232-TTL converter (only using dedicated RS232-MGSM or USB-MGSM cables, guarantees correct communication). The OptimaGSM Manager program allows you to configure panels. Device version updates (firmware upgrade) can be made using the TPR_4 Update utility. Reading and saving the configuration also results in sending the configuration to the touch panels, optionally it is possible to configure the panel (s) from the level of the tab: the touch panel. If the system has a touch panel (s) TPR-1x / TPR-2x and other extension modules, an additional tab is available: **Touch panel after reading the modules connected to the control panel via the "Loupe" icon.**

Main menu of touch panel settings:

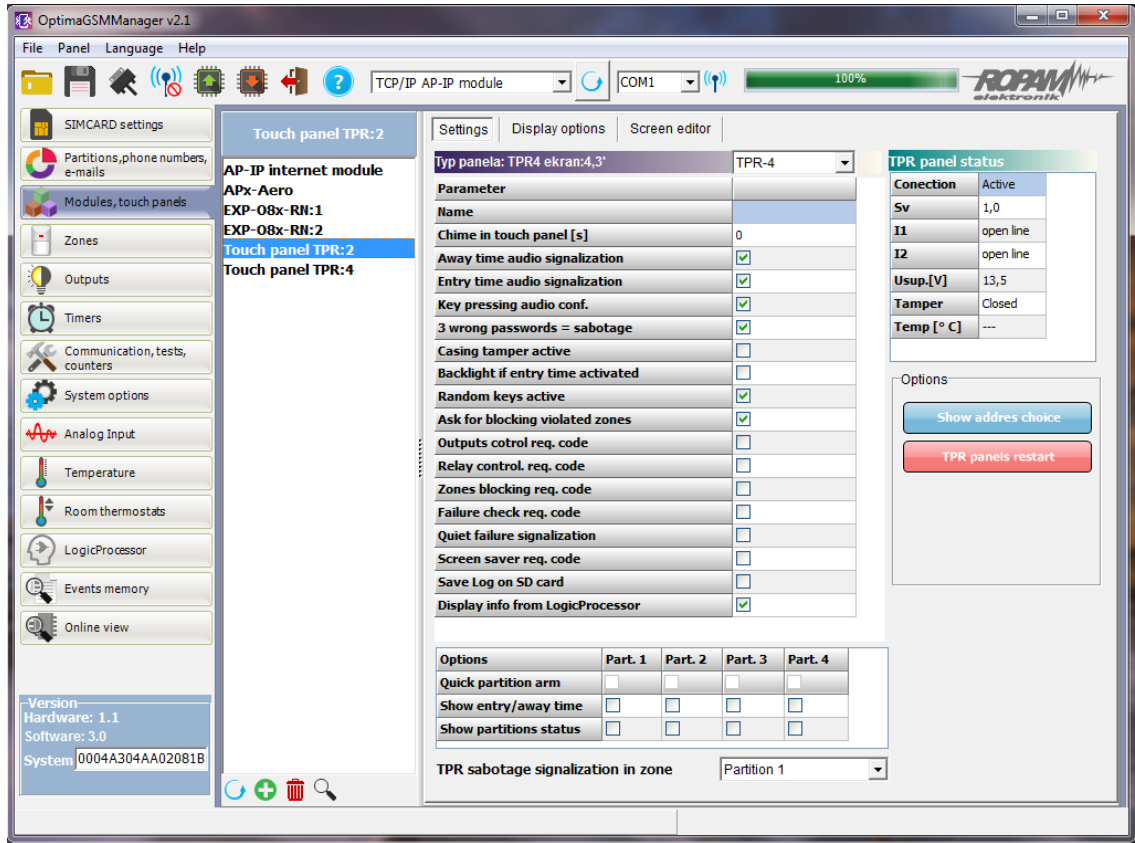

Menu for setting display options, controlling outputs and temperature visibility from individual sensors (1-4).

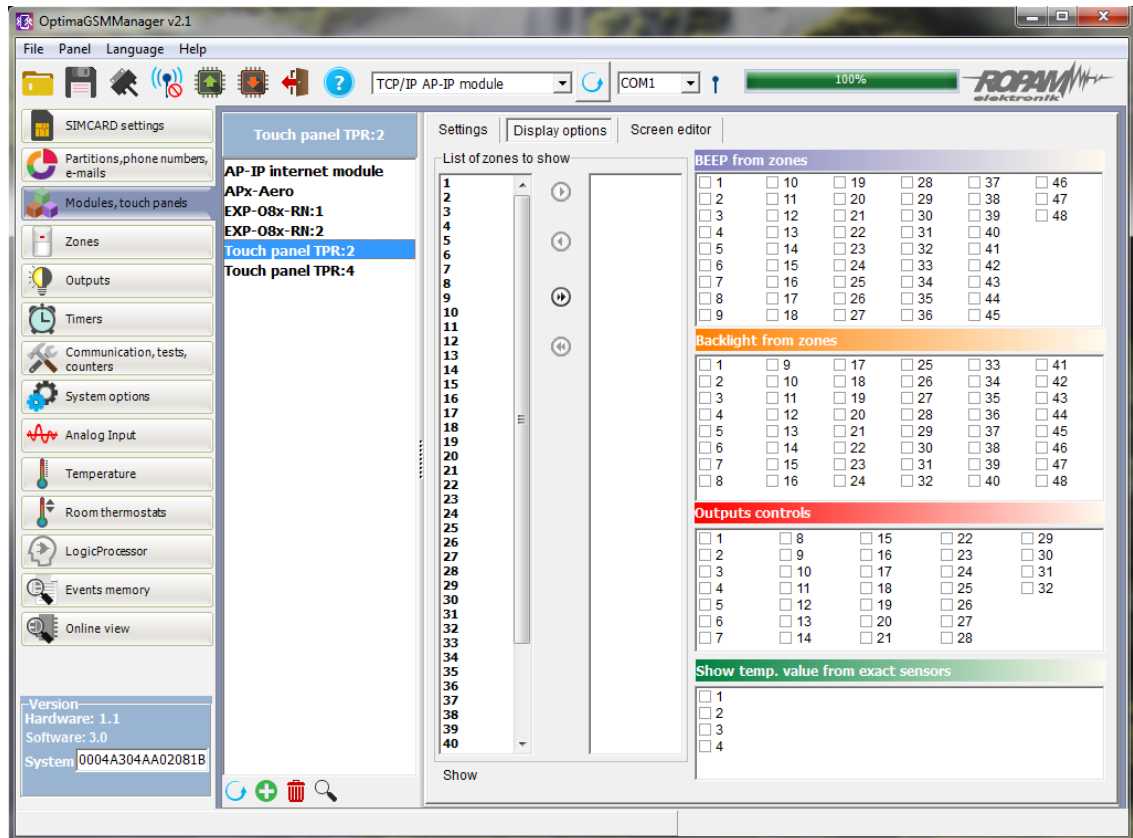

In addition, inputs from the touch panels are visible and configurable in the Inputs tab.

Tab: touch panel / settings.

- Name: allows you to enter a unique name for the touch panel.
- A loud alarm in the panel [s] - defines the time of acoustic alarm signaling in a given touch panel. Setting range: 0-9999 [s].
- Output time signaling: the active option activates the acoustic signaling in the given TP panel during the exit delay.
- Entry time indication: the active option activates acoustic signaling in a given TP panel during entry time.
- Acknowledging the keys: the active option activates the acoustic signaling of pressing the button (detection field).
- 3 incorrect codes = sabotage: entering three incorrect codes will activate the sabotage output, counting is independent for each TP panel.
- Tamper housing active: the active option activates the tamper protection of a given TP panel.

- Backlighting when the time to enter: the active option causes full panel lighting in time to enter.
- Random keypad buttons: the active option will activate a random numeric keypad layout.
- Ask for blocking violated zones: the active option will display a message about blocked zones in the system when the system is armed.
- Output control requires a code: the active option will require the user to enter the code when entering the output control function.
- Relay control requires a code: the active option will require the user to enter the code when entering the relay output control function in a given TP panel.
- Blocking of zones requires a code: the active option will require the user to enter the code at the entrance to the blocking function of individual zones, after disarming the entry system they are unblocked.
- Checking the failure requires a code: the active option will require the user to enter the code at the entrance to the system failure check function.
- Silent trouble signaling: the active option only displays information about failures without switching the busser in the panel.
- Exit from the screensaver requires a code: the active option will require the user to enter the code when exiting the screen saver.
- Saving logs to the SD card: when active - logs from temperature sensors and / or analog input are saved to the SD card in the TPR panel.
- Displaying messages from logic processor: when the option is active, information from LogicProcessor is displayed on the bottom bar of the screen in the panel.

Tab: touch panel / display options.

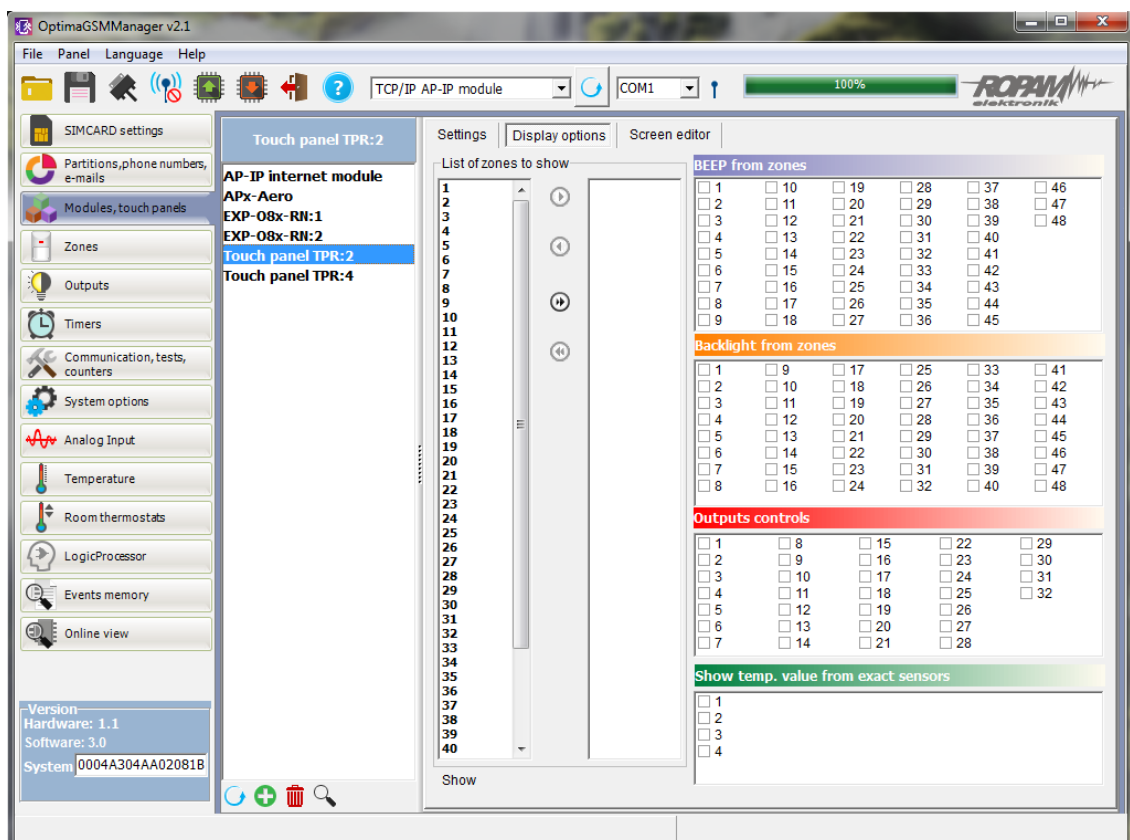

- List of displayed inputs: left column - all visible inputs, right column - inputs not displayed in the panel.
- Input chime: the option allows you to specify the zones which are to generate the chime signal in a given TP panel.
- Highlighting from inputs: this option allows you to specify the zones which are to trigger the full illumination of a given TP panel, exit from the screensaver.
- Outputs control: this option allows you to specify the outputs which control will be available in the given touch panel. The above option allows you to create simple home automation applications: roller blinds control, garage gates, etc.
- Show temperature from selected sensors: the option allows you to select the temperature sensors connected to the T1-T4 inputs in the OptimaGSM control panel and display temperatures on the top bar of the display and in the screen saver mode at the bottom of the screen. Selecting the temperature display option from a given input when no sensor connected to it is displayed with "???"

Tab: Editing screens.

Thanks to the screen editing function, the user / installer can program the appearance and functionality of the touch panel as needed.

The ability to display any icons on two independent screens allows to increase the functionality of the alarm system / home automation and facilitate the use of simple and advanced system functions (logic functions, process control based on events, etc.).

Screen editing menu - OptimaGSM Manager:

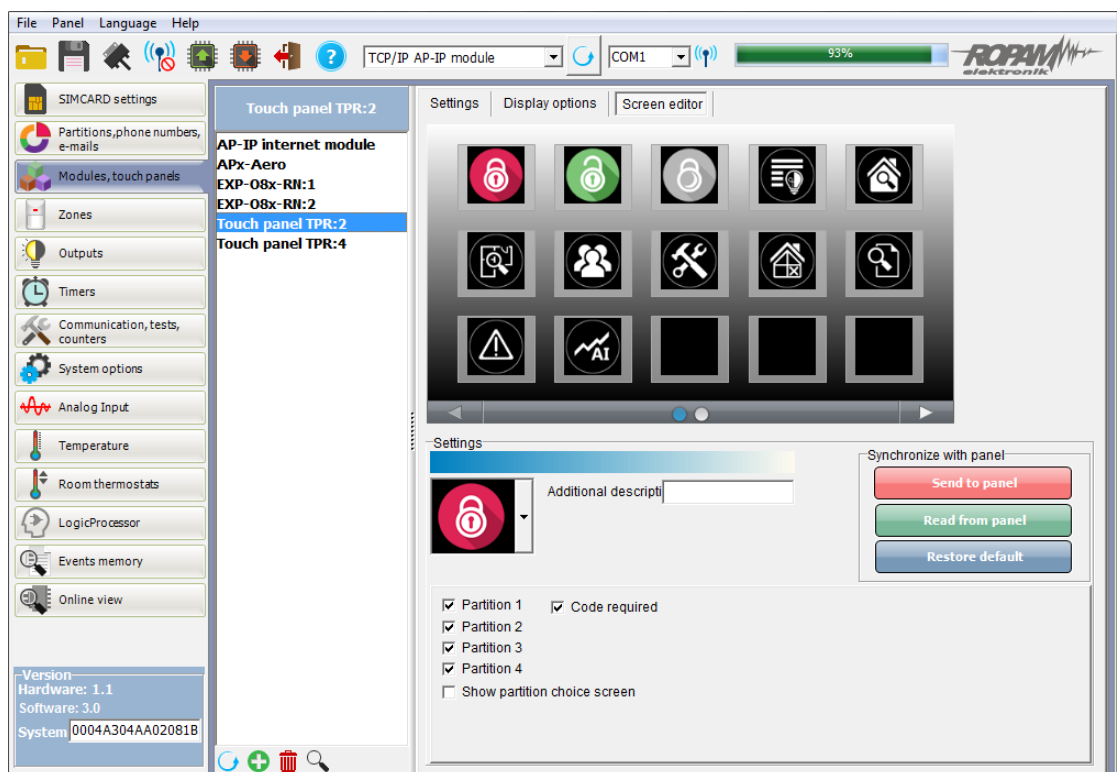

Each of the icons on any screen may have an additional description, which will be visible on the touch panel in the same way as in the program:





In addition, icons described as outputs supporting, for example, IOE-IQPLC modules have the ability to indicate the currently downloaded power on the right side of the icon (bottom right corner). For this function to be active, please mark in the program: "Show the power measured by the IOE-IQPLC module".







The "Show status by input" function indicates the activation of the output if the input changes from "0" to "1"









- dot on the left side of the exit icon:
- white - input = 1,
- empty - input = 0.







Icon descriptions and functions





Icons pictograms are assigned to individual system functions, the meaning and operation of which are described below. TPR-4 touch panel allows you to place any icons anywhere on the two panel screens and some of them assign multiple actions.

Icon	A description of the action
	<p>Full system utilities. Possible (set in OptimaGSM Manager):</p> <ul style="list-style-type: none"> - selection of zones - required code - displaying the zone selection screen
	<p>Disarming the system. Possible (set in OptimaGSM Manager):</p> <ul style="list-style-type: none"> - selection of zones - displaying the zone selection screen
	<p>Night time system. Possible (set in OptimaGSM Manager):</p> <ul style="list-style-type: none"> - selection of zones - required code

Icon	A description of the action
	<p>- displaying the zone selection screen</p>
	<p>Controlling the outputs: Possible (set in OptimaGSM Manager):</p> <ul style="list-style-type: none"> - displaying the outputs to be available (Tab "TPR touch panel -> display options -> controlling outputs) - operation mode - time of operation - description of exits
	<p>Preview of the zone status (violation, tamper, OK). Possible (set in OptimaGSM Manager):</p> <ul style="list-style-type: none"> - list of displayed inputs (Tab "TPR touch panel -> display options -> list of displayed inputs) - description of entrances - operation mode - time of operation
	<p>Building plan preview (requires a MicroSD card with files: plan1.bmp to plan4.bmp). Possibility to edit the layout of detectors on the set from the service menu level in the TPR-4 panel.</p>
	<p>Giving, changing, deleting user codes and names (up to 32).</p>
	<p>Menu of user and service settings.</p>
	<p>Blocking an input or group of inputs. Set in OptimaGSM Manager:</p> <ul style="list-style-type: none"> - entry numer - group blocking of zones - code request to confirm the block <p>After disarming the entry system they are unlocked.</p>
	<p>View the history of events in the system.</p>

Icon	A description of the action
	
	<p>Overview of system failures.</p> <p>If a system failure occurs, next to the icon on the right side a yellow dot will be displayed indicating the presence of a new failure in the system, you can check by clicking the triangle icon with an exclamation mark.</p>
	<p>Preview values for the analog input.</p> <p>Possible (set in OptimaGSM Manager):</p> <ul style="list-style-type: none"> - scaling of voltage values to physical values, e.g. ° C, % Rh, lux, etc.
	<p>Temperature chart from TSR-1 sensors connected to the system.</p>
	<p>Preview of the entrance.</p> <p>Possible (set in OptimaGSM Manager):</p> <ul style="list-style-type: none"> - selecting the entry number - blocking the zone after pressing the icon (after disarming the entry system they are unblocked) - indication of the status from the PLC I / O module input
	<p>Room thermostat.</p> <p>Possible (set in OptimaGSM Manager):</p> <ul style="list-style-type: none"> - thermostat selection (No. 1 or No. 2).
	<p>Controlling the relay in the panel.</p>
	<p>Controlling the control panel output. (1-32).</p> <p>Possible (set in OptimaGSM Manager):</p> <ul style="list-style-type: none"> - the number of the exit - status indication according to entry - requiring a code to be attached - indication of the power measured by the IOE-IQPLC module (if present in the system) on the right side of the icon

Icon	A description of the action
	<p>Controlling the control panel output. (1-32). 1 = white bulb icon 0 = dark bulb icon Possible (set in OptimaGSM Manager, tab "TPR touch panel -> display options -> output control):</p> <ul style="list-style-type: none"> - the number of the exit - status indication according to entry - requiring a code to be attached <p>- indication of the power measured by the IOE-IQPLC module (if present in the system) on the right side of the icon</p>
	<p>Controlling the control panel output (1-32). e.g. roller blinds. Possible (set in OptimaGSM Manager, tab "TPR touch panel -> display options -> output control):</p> <ul style="list-style-type: none"> - the number of the exit - status indication according to entry - requiring a code to be attached <p>- indication of the power measured by the IOE-IQPLC module (if present in the system) on the right side of the icon</p>
	<p>Controlling the control panel output (1-32). e.g. blinds down. Possible (set in OptimaGSM Manager, tab "TPR touch panel -> display options -> output control):</p> <ul style="list-style-type: none"> - the number of the exit - status indication according to entry - requiring a code to be attached <p>- indication of the power measured by the IOE-IQPLC module (if present in the system) on the right side of the icon</p>
	<p>Controlling the control panel output (1-32). e.g. gate. Possible (set in OptimaGSM Manager, tab "TPR touch panel -> display options -> output control):</p> <ul style="list-style-type: none"> - the number of the exit - status indication according to entry - requiring a code to be attached <p>- indication of the power measured by the IOE-IQPLC module (if present in the system) on the right side of the icon</p>
	<p>Controlling the control panel output (1-32). e.g. a garage door. Possible (set in OptimaGSM Manager, tab "TPR touch panel -> display options -> output control):</p> <ul style="list-style-type: none"> - the number of the exit - status indication according to entry - requiring a code to be attached <p>- indication of the power measured by the IOE-IQPLC module (if present in the system) on the right side of the icon</p>
	<p>Attaching the output group. Possible (set in OptimaGSM Manager):</p> <ul style="list-style-type: none"> - number of outputs / outputs - requiring a code to be attached

Icon	A description of the action
	<p>Turning off the output group. Possible (set in OptimaGSM Manager):</p> <ul style="list-style-type: none"> - number of outputs / outputs - requiring a code to be attached
	<p>Humidity indicator - Aero radio sensors. Possible (set in OptimaGSM Manager):</p> <ul style="list-style-type: none"> - list of displayed sensors (up to 8) - sensor number on the widget
	<p>Humidity and temperature indicator - radio sensors of the Aero system. Possible (set in OptimaGSM Manager):</p> <ul style="list-style-type: none"> - list of displayed sensors (up to 8) - display only temp., only% Rh or temp and% Rh
	<p>Basic information about the system: Firmware of the control panel, Panel firmware, Power supply to the control panel and modem, The status of the AP-IP module</p>

Firmware update

The TPR-4 series touch panels have a software update function (firmware). This functionality allows you to change the software to the latest version. The software is updated using the A-USB mini B USB cable and a dedicated update program: TPR_4 update.

The view of the firmware update window:

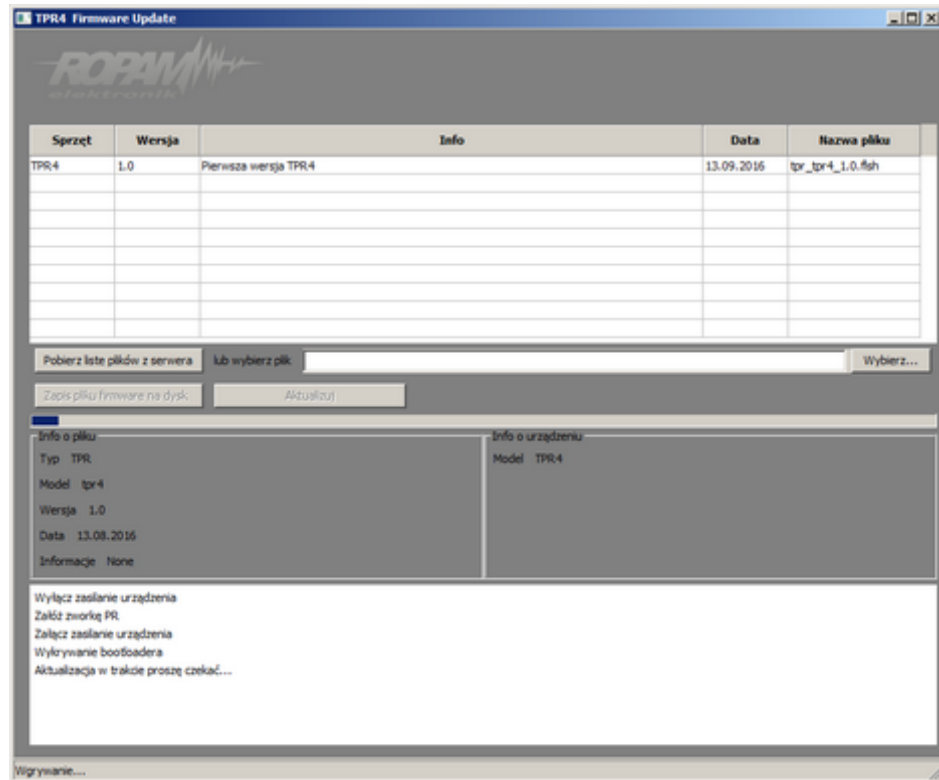

TPR-4 software update procedure

To update the TPR-4 panel firmware:

- run the TPR-4 update program
- turn off the system power
- connect the USB cable to the computer and panel
- put on a PR jumper
- switch on the panel power supply (system)
- select the file by double-clicking
- click the "Update" button
- do not disconnect power when updating the module !!!
- the panel will go off during the update, the buzzer will turn on and emit a continuous signal
- after the update is completed, information will be displayed in the TPR-4 Update program
- remove the PR jumper
- restart the panel (turn the power off and on).

In case of failure with updating the firmware in the panel - repeat the operation from the "Update" step.

TPR-4 panel maintenance

The touch panel does not require special maintenance. During periodic technical inspections, the condition of the screw joints should be checked. If the housing and the touch panel are dirty, clean it using the usual means for LCD computer monitors (it is best to put the panel in the screen cleaning

mode: Settings -> User -> Screen cleaning, the screen will be locked for 60s to be cleaned, all keys will be activated after the time for cleaning has elapsed).

Technical parameters. TPR-4

PARAMETER	VALUE
Power supply voltage	9V÷14V/DC min/max
Power consumption	100mA/140mA @12V (0,72W/2,4W) min/max
Load capacity of the relay output	1A max. @30VDC/50VAC
Input type TPR-1, -1F (programmable)	NO, NC, EOL, 2EOL / NC, 2EOL / NO line resistance for a given type: no violation / violation hi-Z / ~ 30Ω, ~ 30Ω / hi-Z, hi-Z / 2k2, 1k1 / 2k2, 2k2 / 1k1
System communication	RS485 (restricted protocol)
LCD display	4.3 " , TFT LCD, 16.7 million colors, 480x272 pixels
Touchpad	capacitive
Acoustic signaling	~ 80 dB max.
SD card slot (functions)	<ul style="list-style-type: none"> - support for micro SD and SDHC cards (8GB max tested) - building plan (synoptic board) - digital photo frame (100 photos max.) - registration of temperature history from temperature sensors
Housing	IP20 (tamper protection: opening and detaching from the housing base)
Working conditions	environmental class: II T: -10 ° C ... + 55 ° C RH: 20% ... 90%, no condensation)
Connectors	disjoint AWG: 24-12
Dimensions of TPR-4	122,3x88,3x17,3 mm (WxHxD)
TPR-4 weight	175g net

Version history.

TPR-4 VERSION	DATE	DESCRIPTION
1.0	2016.09.21	First version. (OptimaGSM v2.4, TPR-4 v1.0)

RHT-AERO

General description.

Properties

- system module of Aero wireless temperature and humidity sensor (RHT-Aero),
- temperature measurement in the range -20 ° C to 125 ° C - external sensor TSR1-HT, -20 ° C to 70 ° C built-in temperature sensor
- humidity measurement in the 0-100% Rh range without condensation,
- bi-directional, encrypted (AES 128-bit) communication in the ISM 868 MHz band,
- high RF sensitivity up to -110 dBm,
- automatic control of transmit power, up to + 10dBm, depending on strength (RSSI) and transmission quality (LQI),
- coverage above 200m in the open area,
- programming and diagnostics of Aero devices from the control panel level,
- full supervision and status transfer to Aero devices, presence control, link quality, battery status, presence of basic power supply,
- unique ID-Aero of each module allows for proper operation within the range of another Aero system,
- non-volatile configuration memory,
- optical work signaling,
- power supply: 3.6V / DC battery, or external 9-14VDC
- white ABS surface-mounted housing - dimensions: 80x80x25 [mm],
- cooperation with the following systems: OptimaGSM (from 2.2),
- anti-sabotage protection,

Destiny

The RHT-Aero module is designed for wireless temperature and humidity measurement. Thanks to it you can integrate measurements from many devices (up to 8 in the OptimaGSM system) and analyze changes in temperature and humidity parameters.

Warnings

- For safety reasons, the device should only be configured by qualified installers.
- Before proceeding to configuration, read the understanding with the above instructions.
- Do not interfere with the construction or carry out independent repairs.
- It is necessary to maintain possible antistatic protection measures to protect electronic circuits on PCBs against electrostatic discharge ESD.
- In order to meet the requirements of LVD and EMC, the following rules must be observed: power supply, installation, shielding - according to the application.

- Bearing in mind the maximum battery life in the module, avoid installing the module in places subject to extreme ambient temperatures.
- If it is necessary to measure temperatures from the extreme ranges, the RHT-Aero module should be equipped with the TSR-xx sensor and lead it to the places where temperatures affecting battery life occur or connect to the module external power supply - see technical parameters.

Description of the module.

Module versions.

Code	Description
RHT - Aero	Wireless module of Aero temperature and humidity sensor.

Construction and description.

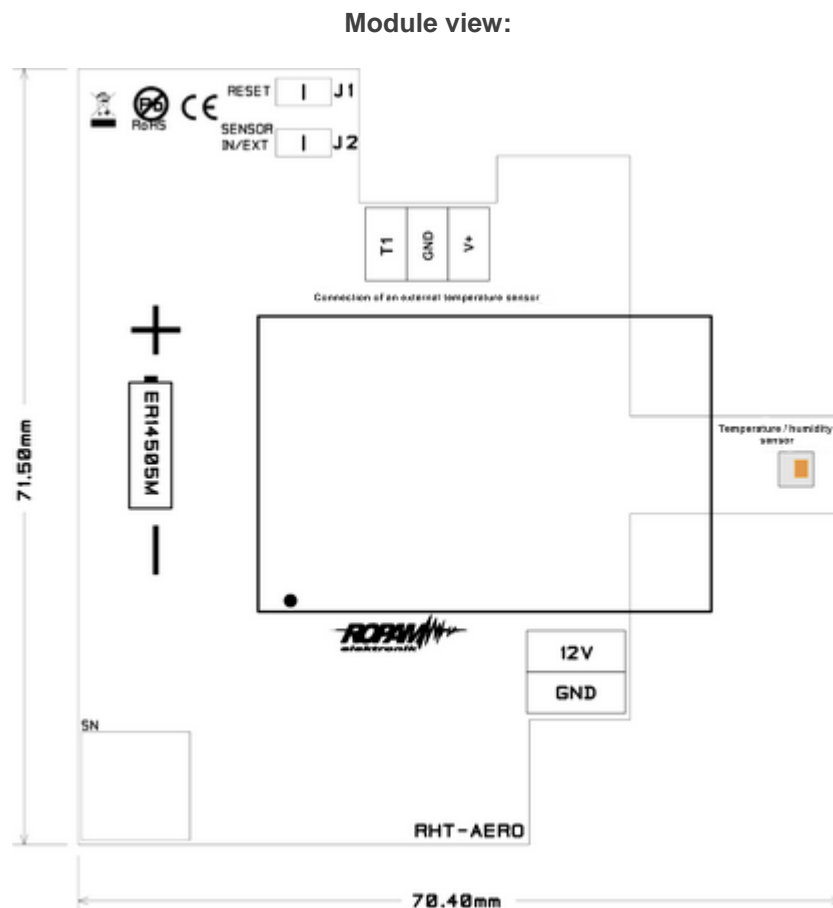

Description of jumpers:

J1 - normal operation - jumper removed, installed - see the installation and programming procedure (deleting the detector from the system).

J2- Temperature sensor selection: removed - internal module sensor, installed - external sensor TSR-xx series manufactured by Ropam Elektronik.

Connector description:

T1 - data from the TSR-xx digital temperature sensor

GND - power ground

V + - supply of an external temperature sensor (**DO NOT COMBINE WITH 12V !!!**)

12V - external sensor supply (eg from the alarm control panel)

GND - masa zasilania

Assembly and installation.**Basic requirements.**

The module should be installed in closed rooms with normal air humidity (RH = 90% max. Without condensation) and temperature in the range of -20 ° C to + 70 ° C. When choosing a mounting location, the following criteria should be followed:

- range of the radio controller (attenuation of the walls of the room: wood / gypsum- about 5% -20%, brick / ceramics: by 20% -50%, concrete / reinforced concrete: by 50% -80%, metal / steel: by 100%)
- assembly optimally centrally in relation to the anticipated range,
- module availability for third parties and sabotage attempts,
- maintaining a safe distance from sources of possible interference (eg 230V / AC power buses - buildings, radio transmitters, etc.).
- maintaining a safe distance from sources of possible interference (eg 230V / AC power buses - buildings, radio transmitters, etc.).

Description and operation of the RHT-Aero module.

The system wiring should be made using low-current cables.

The module checks the status of the environmental parameters:

- temperatures in the range -20 ° C to + 70 ° C, -20 ° C to + 125 ° C using an external TSR1-HT sensor
- humidity in the 0-100% Rh range without condensation

Readings from the module can be sent to the RopamOptima application, read locally in TPR-4 touch panels, text messages, in the RopamDroid application you can read only the temperature from the RHT sensor, in the webserver web browser - only temperature (display configuration in OptimaGSM Manager).

Installation and programming of the RHT-Aero module. 8

1. Install the module housing in a suitable place and enter the appropriate wiring through the cable glands.
2. Connect the power wires to the terminals (wired supply).
3. Install the battery in accordance with the polarity (battery supply when there is no power supply available).

4. Start the system.
5. Program the module: from the centralized level and the OptimaGSM Manager application,
6. Perform functional tests, check range.
7. After completing the installation, perform user training.

Module programming procedure:

1. Start the procedure of adding devices in the Aero controller (system work: OptimaGSM Manager-> AP-Aero-> Enable learning mode.
2. Open the module and install the battery in the first module according to the polarity. The module after combining the connection with AP will generate a series of flashes (blue diode).
3. Repeat point 2 for all modules, the RHT-Aero modules receive the system number according to the order of addition.
4. Check the status of modules in the controller (RSSi, LQI), save settings to RHT-Aero modules.

The procedure of removing the module from the system:

1. A module programmed into the AP controller (with a unique ID-Aero) can not be programmed into another AP, it requires a reset.
2. Remove the battery from the module → set jumper J1 → install the battery → remove the jumper within 10s.
The module will confirm the reset by a series of blue LEDs 10x every 100ms.
3. The module has reset ID-Aero and settings (to factory), is ready for new programming.

Comments:

It is necessary to keep possible antistatic protection measures to protect electronic circuits on PCBs against electrostatic discharge ESD.

RHT-Aero flags in Logic Processor

The temperature and humidity reading functions of Aero wireless sensors in LP are as follows:

- gettw (1-8) (temperature)
- getthw (1-8) (humidity)

Example:

th1 = gethw (1); gets the humidity from sensor 1 aero into the th1 variable

If the control panel detects a sensor read error, it is signaled by the following values: -999 for temp and 255 for humidity.

An example logic script using data from RHT sensors:

The function allows you to control the outputs (devices connected to them) depending on the set parameters (temperature, humidity from a given sensor number, in this example the Aero sensor No. 1, temperature test in the ranges of 2m5-30 degrees Celsius):

```
int tw;
int M1;
int O1;
main(){
gbenv();
```

```
M1=0
O1=geto(1);
while(1){
gbenv();
tw=gettw(1);
O1=geto(1);
if(tw<25&&M1==0){
M1=1;
PRINT("Cold");
};
if(tw>30&&M1==1){
M1=0;
PRINT("Temp. OK.");
};
O1=tofd(1,M1,0,2); // hysteresis of switching the output on and off
seto(1,O1);
};
};
```

Configuration.

Preparing the system for work.

Before connecting the RHT-Aero module to the system, please read the connection documentation.

Power connection / ext. sensor for the module.

When connecting the power supply to the module, take particular care with regard to the ESD protection and correct connection of the power supply to the module.

Connect the optional external temperature sensor TSR1-HT according to the polarity.

Configuration: OptimaGSM Manager.

The system operation module is configured from the control panel level.

Requirements:

- cooperation with the following systems: OptimaGSM (from v2.4),
- OptimaGSM manager program: (version from v2.0)

OptimaGSM Manager: APx-Aero - temperature / humidity detectors.

5

OptimaGSM program tab:

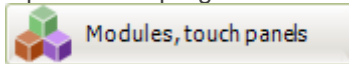

and then:

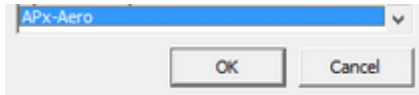

A window is available with a preview of the sensor parameters and the values of the measured parameters:

Sensors		Radio controllers		Temp.Humidity sensors		Signal level graph	
ID	Connected	Temp[C]	RH[%]	Slevel	RSSI[dbm]	LQI	Vbat.[V]
1.	Active	20,8	51	Good	-63	13	3,5
2.	no sensor						
3.	Active	20,6	83	Good	-60	10	3,5
4.	no sensor						
5.	no sensor						
6.	no sensor						
7.	no sensor						
8.	no sensor						

Value display settings on the TPR-4 panel. 5

These settings allow you to display information about the measured parameter values on the TPR-4 touch panel screen.

Below is the settings window from the OptimaGSM Manager utility. The icon allows you to display both parameters at the same time.

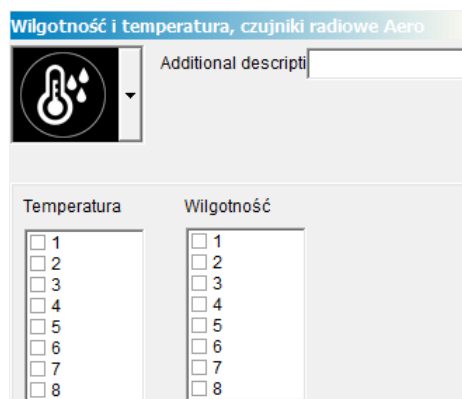

You can also set the display of humidity only using the appropriate icon:

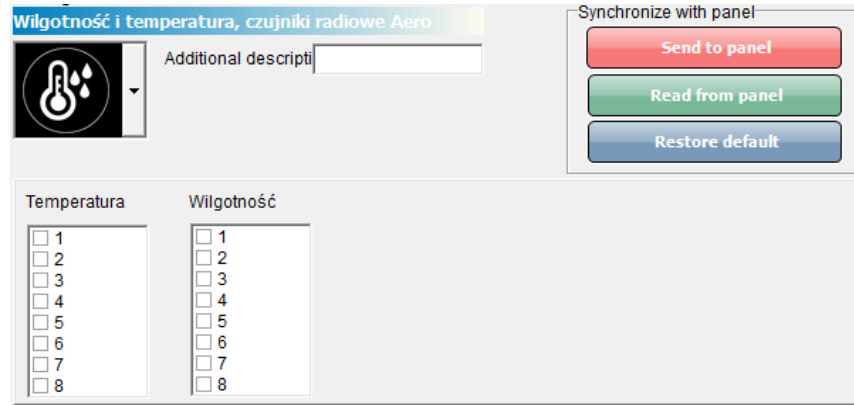

System maintenance.

The device does not require any special maintenance. During periodic technical inspections, it is necessary to check the condition of screw joints, emergency power supply status, clean the PCB with compressed air. The system should be periodically tested for proper operation and communication.

Technical parameters.

Parameter	Value
Power supply voltage	U = 9V-14V DC basic / U = 3.6VDC, battery ER14505M
Power consumption	~ 2mA@12VDC / ~ 0,2mA @3,6VDC
Aero communication in the ISM band	886.000 MHz ... 870,000 MHz sensitivity: -110 dBm, transmission power: up to + 10dBm, FSK modulation
System communication	Ropam NET system bus
Programming	from the level of the alarm control panel - system operation,
Working conditions	environmental class: II temp.: -10 ° C ... + 55 ° C RH: 20% ... 90%, no condensation
Measurement ranges: Rh% Temp. ° C	0-100% without condensation -20 ° C to 125 ° C - external sensor TSR1-HT, -20 ° C to 70 ° C, built-in temperature sensor
Connectors	AWG: 24-18, disjointed
Dimensions, weight.	80x80x25 (WxHxD, mm), antenna built into the PCB surface-mounted ABS cabinet white with optical signaling, ~ 70g

Version history.

Version	Date	Description
3.0	2016.10.03	First version

WARNING:

The new firmware version (from v3.0) in the AP-Aero module only works with Aero devices with the firmware version from 3.x.

VAR-1U

General description.

Properties

- two-way audio communication between the video entry phone and the mobile phone over the GSM network,
- intelligent algorithm for transferring calls to the detection of local call reception,
- MMS transmission with a sequence of images from a door station camera and / or CCTV system - FGR-4 module required,
- transferring calls only during absence of the owner (system arming),
- voice or hidden information about call forwarding,
- adjustable time delay for call forwarding,
- control and change of messages by the user (independent SMS commands: AUDIO, MMS),
- remote control (by SMS command) by a system video door intercom (bolt),
- remote downloading of photos from the door station camera and / or CCTV system, via MMS: 'on request',
- integration with many producers of video intercoms (see list of tested devices): Vidos, Commax, Abaxo, Leleen, Kenwei, PROCOMM, Competition, Eura,
- adjusting the sound level in the doorphone and mobile phone from the device and / or the OptimaGSM Manager program,
- the system does not limit other functions of the systems and increases their functionality,
- functions of reducing costs and number of transfers.

Destiny

The VAR-1U module is used for the integration of intercom systems / video intercoms with the alarm systems / building automation OptimaGSM.

Thanks to its functions, the device raises the functionality of the alarm system with the possibility of remote identification and verification of persons.

Warnings

- For safety reasons, the device should only be configured by qualified installers.
- Before proceeding to configuration, read the understanding with the above instructions.
- Do not interfere with the construction or carry out independent repairs.
- It is necessary to maintain possible antistatic protection measures to protect electronic circuits on PCBs against electrostatic discharge ESD.

- In order to meet the requirements of LVD and EMC, the following rules must be observed: power supply, installation, shielding - according to the application.

Description of the module.

Construction and description.

View of the module board:

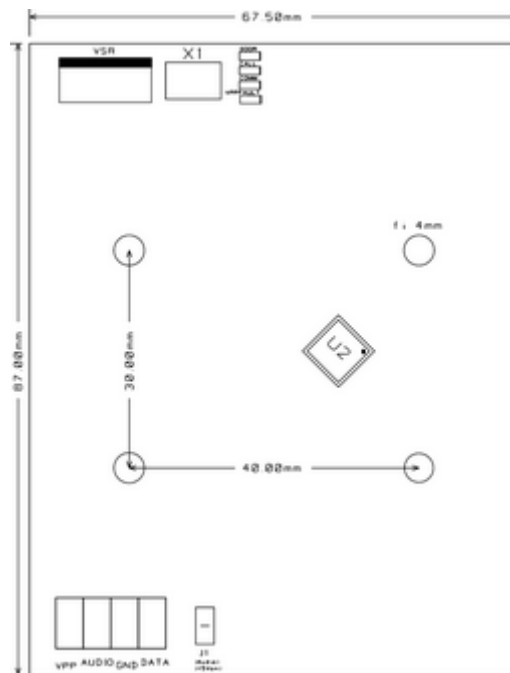

Connector description:

VSR - communication interface for connecting the VSR-1 module - a voice synthesizer allowing to play one voice message for the system user (eg that the call will be redirected to GSM - the owner's cellular phone).

X1 - connection cable of the module with the OptimaGSM control panel

Vpp - power supply of doorphones (selected models),

Audio - audio line,

GND - ground of the system,

Data - data line,

Description of LEDs:

■ DOOR
■ CALL
■ COMM
■ Vpp FAULT

- **DOOR** - lock opening signaling (lighting), blinking 1 x 500ms = wrong data frame from the Leleen / Procomm digital entry phone
- **CALL** - signaling of establishing / ongoing voice connection / call from the interphone (shining)
- **COMM** - blinking every 250ms - correct communication with the Optima GSM panel, correct receiving of data from the Kenwei doorphone: blink 2 x 250ms, redirection active
- **Vpp FAULT** - output failure indication Vpp (glow = failure)

Module versions.

Code	Description
VAR-1U	Gate (interface) of the video intercom. (mounting holes to be mounted on pins)
VAR-1U-D4M	Gate (interface) of a video intercom for DIN TS-35 DIN rail, width 4 modules.

Requirements, installation.

Basic requirements

The VAR-1U module should be used in conditions with normal air humidity (RH = 90% max. Without condensation) and temperature in the range of -10 ° C to + 55 ° C.

Installation.

Preparing the system for work.

Before the VAR-1U module is connected to the system, refer to the documentation regarding the connection of the video intercom to which it will be used.

Please refer to the technical documentation and instructions for the specific model of the video intercom that will be connected to the system because its incorrect configuration and connection may result in damage or malfunction of the Ropam Elektronik system or its damage for which Ropam Elektronik bears no responsibility.

1. Make the correct electrical installation for the video intercom.
2. Connect the installation to the doorphone / video intercom system.
3. Make the OptimaGSM control panel connect to the VAR-1U module.
4. Make the OptimaGSM + Var-1U system connection with the entry phone / video intercom system.
5. Connect the programming cable of the control panel to the RS232 TTL socket.
6. Start the OptimaGSM Manager program.
7. Turn on the system power.
8. Open the COM port in the OptimaGSM Manager program.
9. Identify the modules connected to the control panel.
10. Configure the system.
11. Save the configuration to the control panel.
12. Check operation.
13. Disconnect the control panel programming cable.
14. Perform user training.

Connecting the module to the control panel.

When connecting the module to the system, take particular care with regard to ESD protection and correct connection of signals to the module.

The module is connected to the OptimaGSM control panel by means of the X1 bundle.
The beam plug should be connected to the VSR socket at the OptimaGSM control panel.

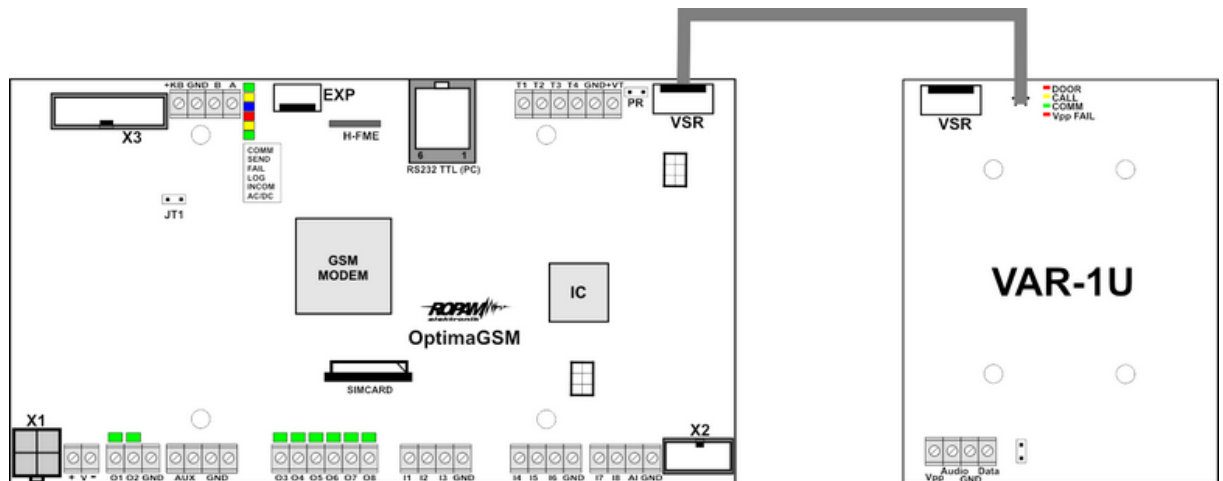

Connecting the VSR-1 module to the VAR-1U module (VSR connector) allows you to play a voice message. We recommend recording messages no longer than 5s.

List of devices cooperating with the module.

The VAR-1U module has been designed to work with video intercoms of many popular brands. Below is a list of devices with which it has been tested.

LP	Brand	Video doorphone - model	Doorphone - model
1	Kenwei	KW-128C	KW-138MC-1B
2	Kenwei	KW-128C	KW-138NE
3	Kenwei	S702C	KW-138NE
4	Kenwei	E706FE	KW138MC-1B
5	Kenwei	E100F/E101F	KW138MC-1B
6	Competition	MT337C-CK2 (2012r.)	SAC5C-CK
7	Competition	MT300C-MK1 (2011r.)	SAC5C-K1 (2001r.)
8	Competition	MT337C-CK2 (2012r.)	SAC551C-CK (2011r.)
9	Vidos	M670W	COMPETITION SAC5C-CK
10	Commax	CDV-50N	DRC-4CAN
11	Commax	CDV-35H	DRC-4CAN
12	Abaxo	M820C	C700C
13	Procomm	PRO-4719(4519)	PRO-420SA(5846)
14	Procomm	PRO-4719(4519)	VP-716A-B(4783)
15	Procomm	VP-716A-B(4783)	VP-716A-B(4783)
16	Eura	VDA-06A03	VDA-81A3
17	Leleen	Seria JB-304, V-25	Seria JB-304, No.15(1)

Connection of the entry phone to VAR-1U

The wiring diagrams for video intercom devices for the VAR-1U module are shown below.

The table represents signals connected to the appropriate pins of the VAR-1U module.

Example:

Vidos: 3 -> Vpp, 1 -> Audio, 2 -> GND, --- Date -> no connection

LP	Manufacturer	Signals	VAR-1U
1	Vidos	3, 1, 2, ---	Vpp, Audio, GND, Data
2	Commax	3, 1, 2, ---	Vpp, Audio, GND, Data
3	Abaxo	B+,A,GND, ----	Vpp, Audio, GND, Data
4	Leleen	---, A(AF), G, ---	Vpp, Audio, GND, Data
5	Kenwei	---, AF, GND, DAT	Vpp, Audio, GND, Data
6	Procomm	Pro4719 (---, Audio, GND, Data), Pro716A video intercom (10, 7, 8, ---) Pro 716A intercom (4, 1, 2, ---)	Vpp, Audio, GND, Data
7	Competition	MT 300C (3,1,2,---), MT 337C (E4, E2, E3, ---)	Vpp, Audio, GND, Data
8	Eura	4,1,2,---	Vpp, Audio, GND, Data

Configuration.

The system operation module is configured from the control panel level.

Requirements:

- central: OptimaGSM (from v2.4),
- OptimaGSM manager program: (version from v2.0)

OptimaGSM Manager: VAR-1U

Identification of the module in the system.

- OptimaGSM program tab:

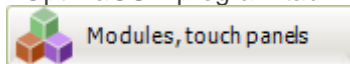

- choose symbol  - the modules connected to the control panel will be identified.

- after that a window will appear with the modules found by the control panel.

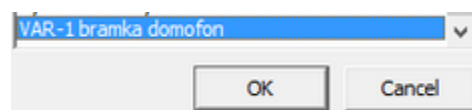



- save the configuration to the central office by clicking:

Then, in the tab concerning the VAR-1U module, the module configuration options are available:

Changing the parameters of the module.

Redirection of the call from the module.

The function allows you to redirect conversations from a video intercom / doorphone when:

For redirection, the conditions above must be met.

always active - the call is forwarded from the doorphone to the mobile phone whenever a call button is pressed on the doorphone

active when I8 violation - the call is forwarded from the doorphone to the mobile phone whenever there is a violation of the entry - 8 (eg detectors at the gate) and during this time the doorphone button will be pressed

active when armed s1-s4 - doorphone forwarding is active only when the zone number is armed.

When the VSR-1 voice synthesizer is installed in the module - first the message saved in the VSR-1 module memory will be played and then the system user number saved in position 1 or 2 will be selected in the tab:

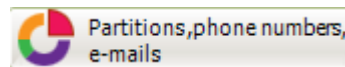

Custom settings.

Custom settings allow you to adjust the parameters of the audio line to achieve the best possible sound quality. Factory settings are recommended for individual device models (they load automatically after selecting the device model).

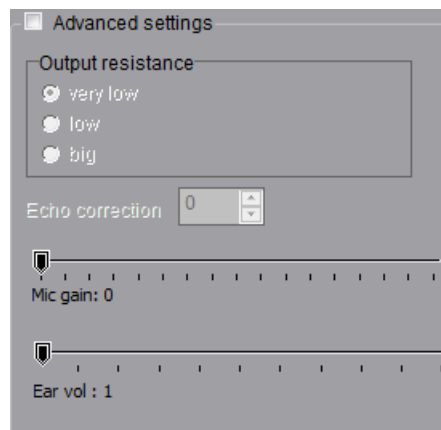

Downloading a photo from the video door phone.

In order to be able to send a picture from the video door phone to the user, the system should be equipped with the FGR-4 photo capturing module to the module, the video signal from the door station camera or other camera (operating in the PAL standard) should be brought.

Downloading a photo from the video intercom follows the FGR-4 module after configuring the options:

- MMS to tel .: send a photo by MMS to a selected phone number (from one to eight users).
- SMS content: information on violation of the input equipped with image capture.
- Attach the sequence pictures to MMS / e-mail: attach a picture or a sequence of photos to the sent message
- Time in [s] - the delay with which they will be generated and after that pictures will be sent from the moment the call button is pressed in the doorphone.

VAR-1 notification								
Tel/e-mail	1	2	3	4	5	6	7	8
Sms to:	<input type="checkbox"/>	<input type="checkbox"/>	<input type="checkbox"/>	<input type="checkbox"/>	<input type="checkbox"/>	<input type="checkbox"/>	<input type="checkbox"/>	<input type="checkbox"/>
Call to:	<input type="checkbox"/>	<input type="checkbox"/>	<input type="checkbox"/>	<input type="checkbox"/>	<input type="checkbox"/>	<input type="checkbox"/>	<input type="checkbox"/>	<input type="checkbox"/>
MMS to tel.:	<input type="checkbox"/>	<input type="checkbox"/>	<input type="checkbox"/>	<input type="checkbox"/>	<input type="checkbox"/>	<input type="checkbox"/>	<input type="checkbox"/>	<input type="checkbox"/>
MMS to e-mail:	<input type="checkbox"/>	<input type="checkbox"/>	<input type="checkbox"/>	<input type="checkbox"/>	<input type="checkbox"/>	<input type="checkbox"/>	<input type="checkbox"/>	<input type="checkbox"/>
E-mail to:	<input type="checkbox"/>	<input type="checkbox"/>	<input type="checkbox"/>	<input type="checkbox"/>	<input type="checkbox"/>	<input type="checkbox"/>	<input type="checkbox"/>	<input type="checkbox"/>
SMS/e-mail content								
TCP code								
VSR-2 messages								
Add pict.seq.to MMS/e-mail	<input type="checkbox"/>							
FLASH type SMS	<input type="checkbox"/>							
Add status	<input type="checkbox"/>							

Downloading images on demand from selected cameras connected to the FGR-4 module by means of MMS consists in sending SMS messages to the control panel in the form of:

Command (##### = access code)	Description	Example
##### photo 1,2,3,4	MMS "Camera images" HEADER CH1 + JPG HEADER CH1 + JPG HEADER CH1 + JPG HEADER CH1 + JPG + CONTENT SMS "STATUS"	1212 photo 1,3,4 (the command will download images from cameras 1.3 and 4 via MMS and the system status is included in the content)

Bolt control using DTMF.

The VAR-1U module enables the remote opening of the bolt using the DTMF code during the ongoing voice connection between the user and the OptimaGSM system.

Call forwarding after [s] - the function allows to play a message from the VSR-1 module installed in the VAR-1U door intercom (we recommend that the redirection time should not be shorter than the message duration in the VSR-1 module).

To use the option of opening the bolt using the DTMF code, enter the code (1-4 digits) in the field, and the DTMF code is confirmed by pressing "*" "

Dialing configuration window and DTMF opening code:

The image shows a software interface for dialing configuration. It features two input fields: 'Forward after [s]' with a numeric value of '0' and a spin button, and 'DTMF open lock code' with an empty text input field.

Switching bolt.

The function of turning the lock allows remote opening of the gate by means of DTMF code or the SMS command.

The opening of the bolt follows:

- remotely by the user - DTMF, code from 1 to 4 digits, confirmation "**"
- remotely by the user - SMS, example: ##### doorlock (##### = access code)
- locally - a button in the video door phone

SMS command for control of bolt.

Command (#### = access code)	Description	Example
#### doorlock	switching on the system of the bolt relay in the door station (opening the gate / wicket)	1111 doorlock

System maintenance.

The device does not require any special maintenance. During periodic technical inspections, it is necessary to check the condition of screw joints, emergency power supply status, clean the PCB with compressed air. The system should be periodically tested for proper operation and communication.

Technical parameters.

Parameter	Value
Power supply voltage	U = 12-14VDC
Programming	from the level of the alarm control panel - system operation,
Working conditions	environmental class: II temp.:10°C ... + 55°C RH: 20% ... 90%, no condensation
Dimensions, weight.	67.5 x 87 x 17.53 (WxHxD, mm), ~ 30g without housing, 71 x 90.2 x 57.5 (WxHxD, mm), ~ 90g housing D4M,

Version history.

Version	Date	Description
1.0	2016.08.30	First version.

3. Installation and commissioning.

Basic requirements.

The system built on the basis of the OptimaGSM control panel, touch panels and other required elements are intended for assembly by a qualified installer, holding appropriate (required and necessary for a given country) permissions and licenses to connect (interfere) 230V / AC installations and low-voltage installations. The devices should be installed in closed rooms with normal air humidity (RH = 20% - 90% max. Without condensation) and temperature in the range -10 ° C ... + 55 ° C. Before starting the installation, a load balance of the power supply should be prepared. Since the system power supply is designed for continuous operation, it does not have a power switch, therefore proper overload protection should be provided in the power supply circuit. You should also inform the user about the method of disconnecting the power supply from the mains voltage (usually by separating and marking the appropriate fuse in the fuse box). The electrical installation should be made in accordance with applicable standards and regulations. When choosing the place where the control panel is installed, the communication module should be guided by the following criteria:

- GSM network coverage (the SIM card operator used for the module),
- availability and distance from sources of alarm / trigger signals (eg alarm control panel),
- availability or possibility of mounting in the immediate vicinity of the power source,
- room availability for third parties and sabotage attempts,
- maintaining a safe distance from sources of possible interference (eg 230Vac power buses - buildings, radio transmitters, etc.).

The backup time during battery operation is defined by the PN-EN 50131-6 formula:

$$Q_{bat} = 1.25 * [(I_d + I_z) * T_d]$$

where:

Q_{bat} - battery capacity [Ah]

1.25 - a factor that takes into account the decrease in battery capacity due to aging

I_d - the current collected by the receivers during the surveillance [A]

I_z - current drawn for the power supply's own needs [A]

T_d - required length of supervision [h].

Comments:

- to meet level 2 of PN-EN 50131-6 standard, emergency power supply must ensure operation for a minimum of 12 hours (time T_d).

Wiring the system.

The system wiring should be made with the use of low-current cables. In addition, it should be in accordance with the rules and standards, in particular this applies to the selection of the type and cross-section of cables, the distance from the 230V / AC wiring, etc.

The RopamNET system bus (EIA-485) should be made using:

- UTP, STP, FTP so-called twisted pair cable,
- YTSKY (optional) telecommunications (pairing) cables,

Signals and power supply should be run in one cable. If shielded cables are used, the screen should be connected point-by-point to the PE circuit in the control panel housing.

The RopamNET bus must have a loop architecture and the terminal devices must have a 120Ω termination. For installations made in the star architecture, use 2 pairs of wire and make loops,

i.e. 1 pair brings the bus to the device and the other goes out to the next and in the central place it should be combined with the art.

The remaining connections should be made in accordance with the device manufacturer's instructions, and if there are no such cables, the following cables can be used:

- YTDY, YTLZ,
- UTP, STP, FTP,
- YTSKY,
- other low-current, compliant with regulations, standards, required cross-sections.

Connection of the RopamNET bus.

The system wiring should be made using low-current cables. In addition, it should be in accordance with the rules and standards, in particular this applies to the selection of the type and cross-section of cables, the distance from the 230V / AC wiring, etc.

The EIA-485 system bus should be made using:

- UTP, STP, FTP so-called twisted pair cable,
- YTSKY (optional), telecommunications (pairing) cables,

Signals and power supply should be carried out in one cable. When using shielded cables, the screen should be connected point-by-point to the PE circuit in the control panel housing.

The RopamNET bus must have a loop architecture and the terminal devices must have a 120Ω termination (JT jumpers installed).

In the case of installations made in the star architecture, 2 pair of wire should be used and loops should be made, ie 1 pair will lead the bus to the device and the other will go out to the next one.

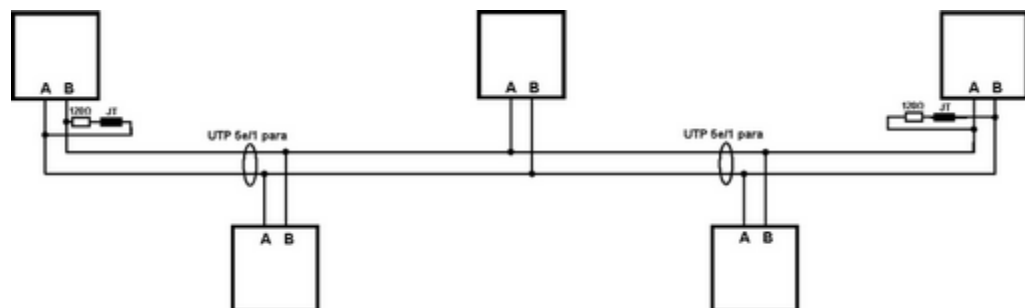

Devices with RopamNET bus:

Control panel	Expander
OptimaGSM	TPR-1x
NeoGSM	TPR-2x
NEO	RF-4x
	APx-Aero
	PSR-ECO-5012-xx
	EXP-I8-RN-xx
	EXP-O8R-RN-xx
	Hub-IQPLC-xx

1. Control panel + one device on the bus.

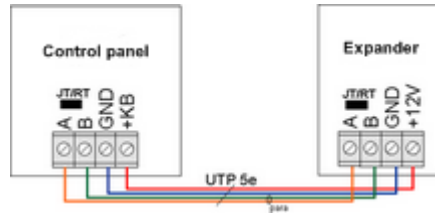

Control panel	Expander
A	A
B	B
GND	GND
+KB	+12V
JT= ON	JT/Rt= ON

2. NeoGSM / OptimaGSM control panel + three and more devices on the bus.

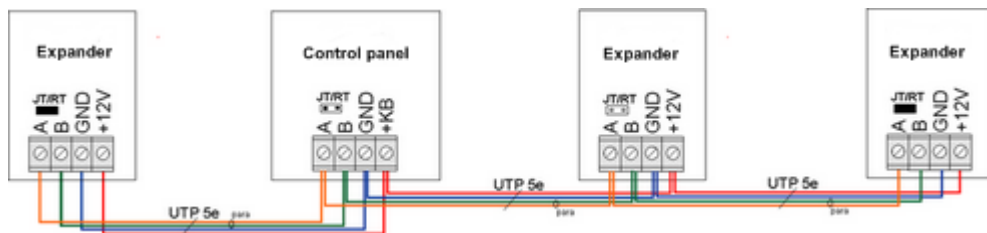

Expander	Control panel	Expander	Expander
A	A	A	A
B	B	B	B
GND	GND	GND	GND
+12V	+KB	+12V	+12V
JT/Rt= ON	JT= OFF	JT/Rt= OFF	JT/Rt= ON

3. Cross-sections of RopamNET bus cables.

Recommended minimum cross-sections for UTP 4x2x0.5mm cable (0.5mm - ø conductor), with one device connected. The minimum supply voltage at the terminals of a given device can not be lower than 8V / DC (ie at a minimum battery voltage of 9.5V-10.0V, the drop on the power supply wires can not be higher than 1.5V).

Signal	to 150m.	to 300m.
A	2x0,5 (1 pair)	2x0,5 (1 pair)
B		
GND	1x0,5	2x0,5 (1 pair)
+KB	1x0,5	2x0,5 (1 pair)

Connecting devices to inputs.

The system can operate up to 32 wired detectors or 40 if there is no Aero system installed. The system input can work with any triggering devices available on the market, for example:

- motion detectors, magnetic with outputs: NC (normally closed), NO (normally open),
- alarm outputs: relay outputs (RELAY - potential-free contacts),
- open collector (OC, - BELL): power control "minus", potential outputs,
- anti-tamper contacts: signaling devices, casings, etc.

Device	Number of zones	Max. Amount in the system
OptimaGSM-xx	8	1
EXP-I8	8	1
EXP-I8-RN-xx	8	2
TPR-xx	2	4

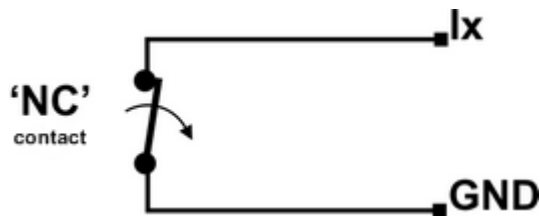

Input in configuration: NC.

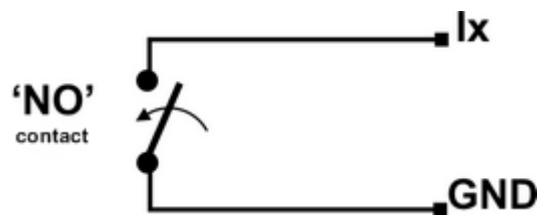

Entry in configuration: NO.

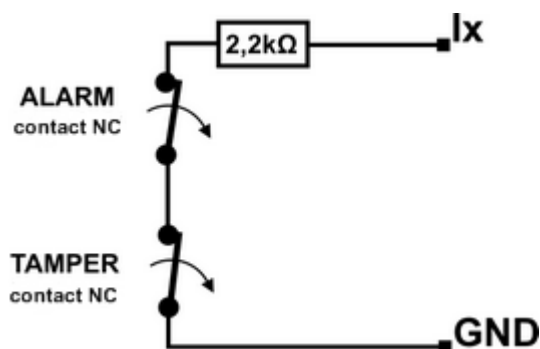

Input in configuration: EOL (diagram with tamper contact).

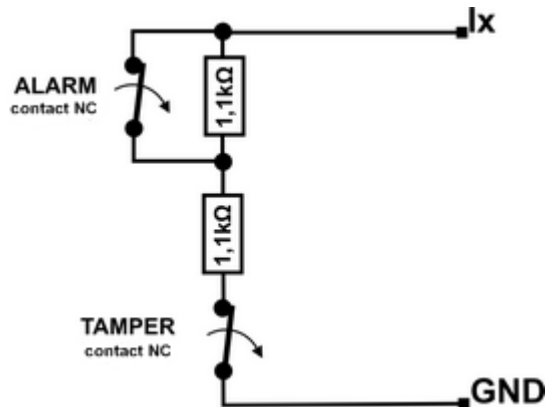

Input in configuration: 2EOL / NC (eg typical PIR motion detectors, magnetic detectors).

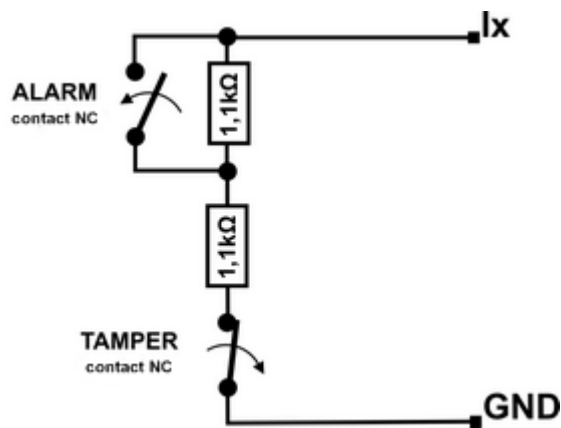

Input in configuration: 2EOL / NO (non-standard detectors with NO output).

Connecting devices to the outputs.

The control panel has binary outputs (0/1) allowing connection of 12VDC signaling devices, 12VDC relays, LED diodes of other devices controlled by a voltage signal. Expanders and modellers, depending on the version, have potential or potential-free outputs. The maximum operating parameters are defined independently for individual types of outputs and it is unacceptable to exceed them.

Device	Outputs type	Comments
OptimaGSM-xx	potential, transistor O1-O2: 12V / 1A O3-O8: type OC GND / 0.1A	O1- O2, outputs with full electronic protection and continuity control (connection of the siren).
EXP-O8R-RN-D9M	potential-free, relay O1-O8: 230VAC / 8A	Dedicated to control 230V electrical devices.
EXP-O8T-RN-xx	potential, transistor O1-O8: OpenDrain GND type / 0.7A	O1- O2, outputs with full OCP short-circuit protection, overload OLP and OVP overvoltage.

Device	Outputs type	Comments
IOE-IQPLC	potential, relay 230VAC / 8A	N power control 230VAC. Power measurement of the receiver.
IO-IQPLC	potential-free, relay 230VAC / 8A	
TPR-xx	potential-free, relay 30V / 1A	
RF-4	potential-free, relay O1-O2: 30VDC / 1A potential, transistor O3-O8: type OC GND / 0.1A	

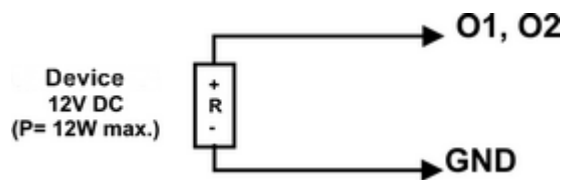

O1-O2 output of OptimaGSM board: connection of 12V DC siren (acoustic and / or optical).
Notes: O1, O2 require a 2K2 Ohm load at the end of the line for circuit continuity monitoring.

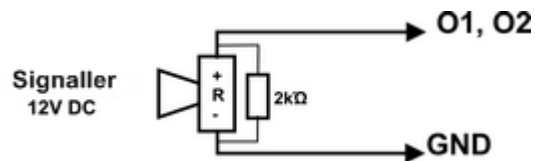

O1-O2 output of OptimaGSM board: connection as power supply, eg signaling device.

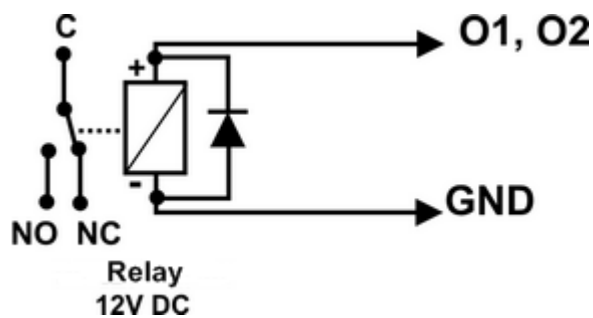

O1-O2 output of the OptimaGSM board: connection of a 12V DC relay.

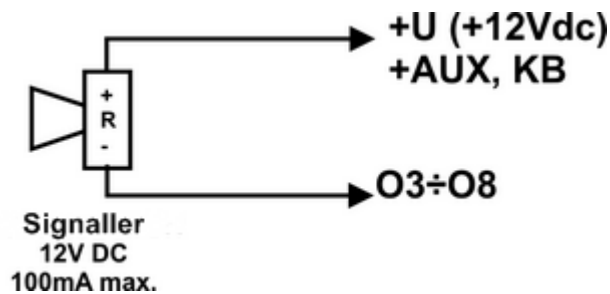

O3-O8 output of OptimaGSM board: connection of 12VDC / 100mA siren max. (acoustic and / or optical).

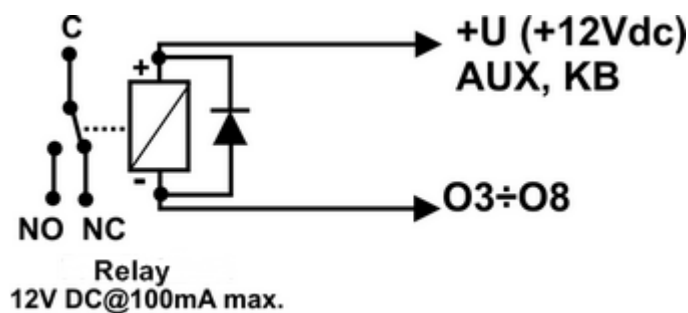

O3-O8 output of OptimaGSM board: connection of 12V DC relay, + V = AUX power supply.



O3-O8 output of OptimaGSM board: LED connection, + 12V = AUX power supply.

- **AUX**, power supply output + 12V / 1A (second terminal = GND) to power detectors, relays. The output has an autonomous protection against short-circuit, overload and temperature (automatic return).

- **+ KB**, power supply output + 12V / 1A (second terminal = GND) to power touch panels and system devices. The output has an autonomous protection against short-circuit, overload and temperature (automatic return).

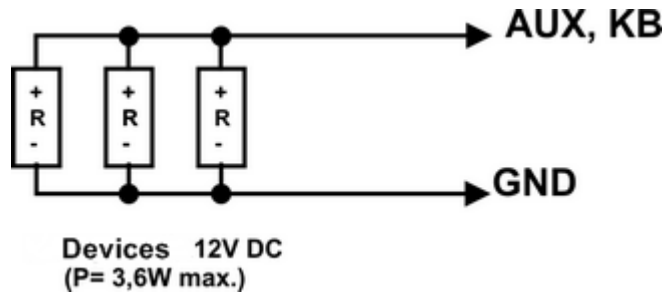

AUX output, + KB OptimaGSM board: connecting 12V devices power supply.

Connecting the signal to the AI input.

The analog input AI-GND is used to operate sensors, transducers with analogue 0-10V output. The input can be used to measure the DC voltage, e.g. via a voltage divider. The reference potential for the AI input is GND, the ground of the measuring system must be connected to the GND OptimaGSM terminal. The input has the possibility of scaling to a physical value (two-point).

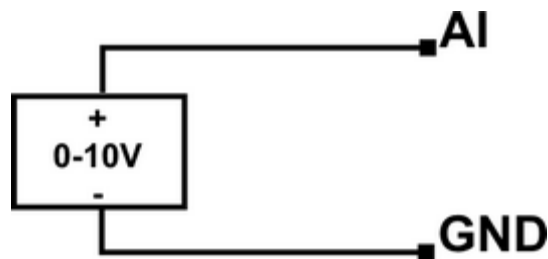

AI input: connection of a 0-10V voltage signal relative to common GND ground (asymmetric).

Connection of temperature sensors.

The system supports 4 temperature sensors, wired. OptimaGSM board has dedicated connectors for power supply and communication with sensors of the TSR-1 series.

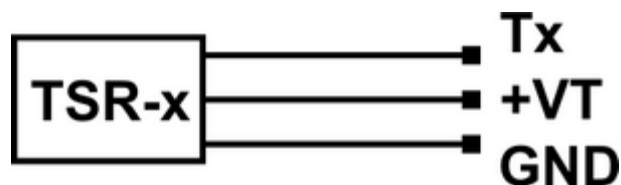

Connection of a speech synthesizer, audio module.

The control panel is equipped with a VSR socket for connecting the VSR-2, VSR-1 voice synthesizer or the AMR-1 audio module allowing the object to be listened to. The speech synthesizer allows you to record and transmit a voice message in the event of an event in the system. Playback occurs automatically when you make a voice call. The message is played cyclically to end the connection. The speech synthesizer is connected directly to the VSR connector and after the power is turned on we record messages (built-in microphone). The message is remembered when power is lost (disconnecting the synthesizer). The synthesizer has a MINIJACK output for listening to the recording.

To connect the control panel and AMR-1 modules or the + VSR-2 + AMR-1 control panel, use a 5-pin plug. The AMR-1 audio module allows you to listen to the audio object in the event of an alarm or voice call (connections to the module from authorized numbers). The connection should be made according to the diagram using a microphone cable.

VSR	Description
1	GND - 0V, mass of power and audio signal
2	AUDIO IN audio signal input (microphone)
3	T+ synthesizer triggering (+ 5Vdc)
4	AUDIO OUT audio signal input, (speaker)
5	+12V – power supply of a speech synthesizer or audio module

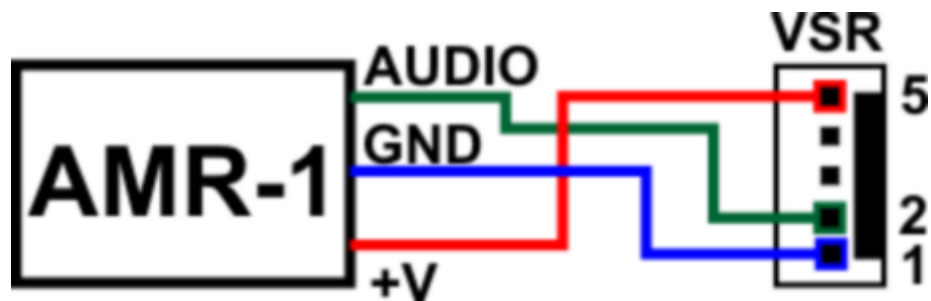

Connecting the IQPLC system.

Connection Hub-IQPLC-D4M for 1-phase installation.

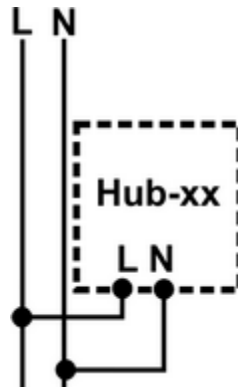

Connection Hub-IQPLC-D4M for 3-phase installation (recommended).

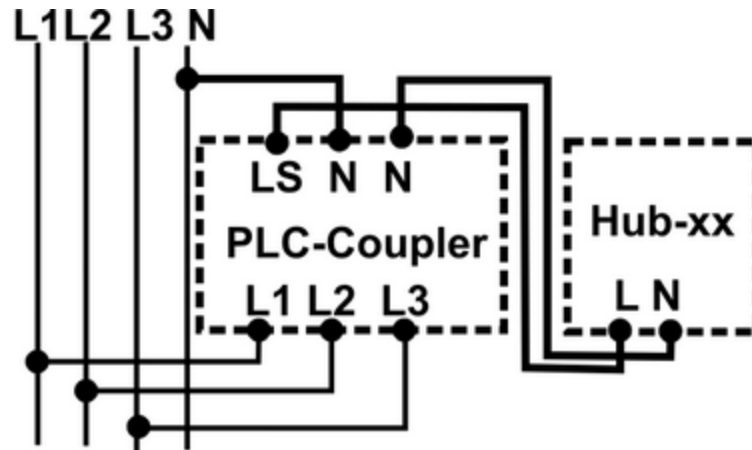

Connection of the AP-IP communication module.

Description of AP-IP.



Connector / element	Description / Function
ETH	RJ45 socket, LAN (ETH) 10/100 BaseT port,
RS232TTL	4-pin connector for connecting the communication with the OptimaGSM board using a 4-pin / RJ12 cable
Wifi antenna	Wifi panel antenna with 20 cm connector connected to the AP-IP board UFL connector.
2x3pin connectors	connectors, pins for installing the module on the OptimaGSM board

Comments:

All connections and installation should be made while the motherboard power supply is off. Incorrect installation of the AP-IP module in the motherboard may cause damage to the devices. AP-IP is supported from: OptimaGSM v1.9, TPR-xx_OptimaGSM v1.3, OptimaGSM Manager 1.6.

Connection of the AP-IP communication module.

1. The AP-IP module should be installed on the OptimaGSM mainboard in accordance with the orientation and two sets of pins should be plugged into the sockets on the motherboard (see photo below).



2. In case you used a Wifi connection, install a vertical Wifi antenna on the housing or cabinet.
3. When using an ETH connection, connect the UTP LAN cable to the ETH connector.
4. Connect the programming cable to the service computer: USB-MGSM or RS232-MGSM (selection depending on available ports in the service computer).

5. Start the OptimaGSM Manager program (in the version dedicated to a given control panel version), select the COM port for the communication cable, the connection will take place automatically.
6. Open the "Modules, TPR panels" tab to start "Identification" and detected modules, expanders including AP-IP to be rewritten to the control panel resources and save the settings to the control panel.
7. Configure the AP-IP module.

Connecting the power supply to control panel.

The control panel is available in two power versions,
 OptimaGSM: power supply 9 ÷ 14V / DC
 OptimaGSM-PS = 16 ÷ 20V / AC or 20 ÷ 30V / DC

In the control panel application, a supervised power supply must be used, ie: **OptimaGSM-PS or OptimaGSM + PSR-ECO-5012-RS.**

The choice depends on the current balance of the system, temperature and working conditions, efficiency requirements.

If the system does not charge more than 1.5A and works in a stable room temperature, OptimaGSM-PS can be used.

If the system has a consumption greater than 1.5A (max. 3.0A) or works in a variable temperature, then OptimaGSM + PSR-ECO-5012-RS is required.

The PSR-ECO-5012 power supply unit exceeds the requirements of the PN-EN 50131-6 power supply standard, type 2.3 type A.

Connector / element	Description / Function
+ V -	OptimaGSM = 9 ÷ 14V / DC (according to polarization) OptimaGSM-PS = 16 ÷ 20V / AC or 20 ÷ 30V / DC (according to polarization).
X1	OptimaGSM: connector for connecting the PSR-ECO-5012-RS power supply; (power supply and RopamNET) (if the PSR-ECO-5012-RS is used, the + V- terminals should be left unused)

Installation and start-up procedure.

1. Perform complete wiring: signaling and power supply.
2. Install the enclosure, cabinet and insert the wiring through the cable gland.
3. Install and connect wiring in cooperating devices: detectors, sirens, touch panels, expanders, etc.
4. Install the SIM card in the control panel (the card must not be installed while the power supply is on!)
 - insert vertically into the SIMCARD connector, the SIM card oriented with a slit (lock) towards the right edge of the PCB and the SIM contacts towards the O7-O8 outputs (in normal orientation).
5. Install the control panel, expanders and modules in the housing, cabinet.
 - a. in the system casing (O-R3x, O-R4x) on pins included in the set with the casing,
 - b. in cabinets, switching stations by means of a clip fastening the DIN housing on the TS35 mounting rail.

6. Connect optional expanders to dedicated connectors:
 - a. connector X1: power supply PSR-ECO-5012-RS,
 - b. VSR connector: VSR-2 / VSR-1 voice synthesizer or AMR-1 audio module or VAR-1 doorphone,
 - c. connector X2; EXP-I8 local input expander,
 - d. EXP connector: FGR-4 module for MMS.
 - e. connector X3: LED ALARM panel to send optical signaling to the cabinet / enclosure door.
7. Connect the motherboard power supply:
 - a. OptimaGSM-PS: 17VAC voltage from the transformer under terminals + V- (any polarization),
 - b. OptimaGSM: system PSR-ECO-5012-RS power supply for X1 connector,
 - c. OptimaGSM - optional 12VDC power supply for terminals + V- (according to polarization), this configuration does not meet the requirements of the standard and does not allow control of the basic power supply,
8. Connect the devices to the appropriate terminals: detectors, sirens, relays, devices on the RopamNET bus, temperature sensors.
9. Connect the external antenna to the FME-M connector, in the system housings remove the connector from the H-FME holder and mount in the housing.
10. Turn on the power supply of the control panel.
11. Connect the programming cable to the service computer: USB-MGSM or RS232-MGSM (selection depending on available ports in the service computer).
12. Start the OptimaGSM Manager program (in the version dedicated to a given control panel version), select the COM port for the communication cable, the connection will take place automatically.
13. Open the "Modules, TPR panels" tab, start "Identification" and detected modules, expanders to the control panel resources and save settings to the control panel.
14. Complete the system configuration by editing the tabs from "SIM card settings" to "LogicProcessor" depending on system requirements and configuration, save settings to the control panel.
15. Carry out tests and trials, go to the "Online Review" tab to check the system status, among others: failures, operation of inputs, control of outputs, GSM status, temperature measurement, etc.
16. Terminate programming and disconnect the cable from the RS232TTL connector.
17. After programming, perform functional tests, user training, transfer the system to the user.

Comments:

Possible antistatic protection measures should be taken to protect electronic circuits against electrostatic discharge.

Do not turn on the power of the device without an external antenna connected.

Do not turn on the power of the device without an external antenna connected.

In the case of assembly in housings adapted to the mains power supply (with a transformer) to the PE ground terminal, do not connect the N ("zero") conductor of the 230VAC mains power supply.

Connecting the N to PE cable can damage electronic circuits, GND potential is galvanically connected to PE! if there is no separate electric shock circuit in the facility, the clamp should be left free).

The procedure for a reset to factory settings.

If the control panel needs to be reset to factory settings then the procedure should be performed:

1. Turn off the control panel power supply (completely).
2. Insert the jumper on the X3 connector pins as shown in the figure (the second vertical pair from the + KB connector).
3. Activate the control panel power supply.
4. The COMM / SEND / FAIL / LOG / INCOME / AC / DC LEDs are permanently on and then blink 3 times.
5. Turn off power to the control panel and remove the jumper on connector X3.

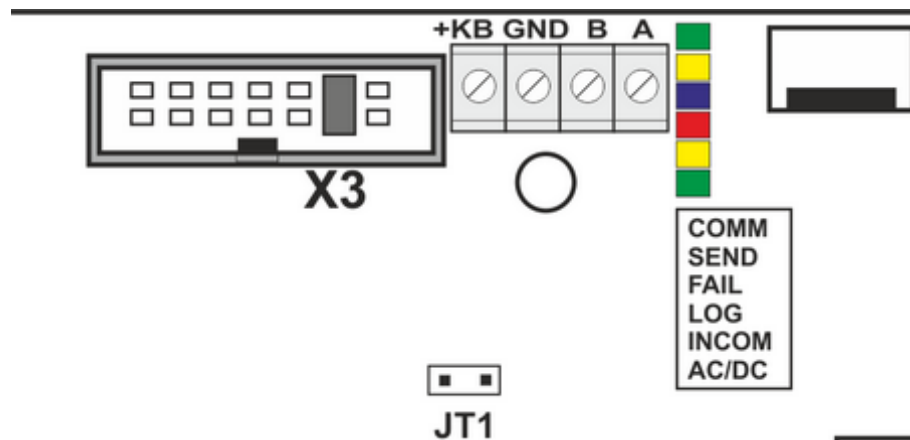

Comments:

After the reset, the control panel is reset to factory settings, no modules are in memory.
TCP / IP encryption key after reset to factory settings: "ABCDEFGHIJKLMNPO".

4. System configuration.

Programming and configuration of the system (control panel) can be performed:

- from the OptimaGSM Manager program; locally connecting the entire system and functions,
- from the OptimaGSM Manager program; remote connection whole system and functions,
- from touch panel service menu level, touch panel functions.

System configuration: OptimaGSM Manager.

The program is designed to work on PCs with the operating system WINDOWS XP / VISTA / Windows7 / Windows 8.x., 10. Communication between the application and Ropam devices takes place via: RS232 or USB port using communication cables with a built-in RS232-RS232-TTL or USB-RS232-TTL converter. The Partner GSM program allows you to configure devices and upgrade the device version (firmware replacement).

WARNING;

- only using dedicated RS232-MGSM or USB-MGSM cables, guarantees correct communication and upgrade functions,
- for Windows 7, Windows 8 program installer and the application for correct operation must be run with the level of access as the system administrator,
- before connecting the USB-MGSM cable, the VCP certified drivers must be installed for WINDOWS: during the installation of the Partner GSM program (with system administrator privileges for Windows 7/8) from the CD, from the www.ropam.com.pl website or downloaded from the manufacturer's website (for the FT232B system)
<http://www.ftdichip.com/Drivers/VCP.htm>

Description of the program toolbar.

The program has a text-graphic menu. Unavailable operations or functions for a given device type are presented as inactive (gray: icons or subtitles). The communication functions are only available after the COM port (RS232 or USB) has been properly configured and communication with the control panel has been started.

Warning:

Before saving the configuration to the device, leave all fields and windows to edit, because until the confirmation (leaving the window) changes in the configuration are the data before editing the field!

Local configuration via COM port.

PC service computer: USB or COM	Cable: USB-MGSM lub RS232-MGSM	Control unit: RS232TTL port
------------------------------------	---	--------------------------------

The control panel is configured via the RS 232 TTL interface and dedicated pre-programming cables.

Comments

- only the use of dedicated RS232-MGSM or USB-MGSM cables guarantees correct communication and upgrade functions.

1. Turn on the power supply of the control panel.

2. Connect the programming cable to the service computer: USB-MGSM or RS232-MGSM (selection depending on available ports in the service computer).
3. Start the OptimaGSM Manager program (in the version dedicated to a given control panel version), select the COM port for the communication cable and open it ('plug-in'), the connection will take place automatically.
4. Open the "Modules, TPR panels" tab, start "Identification" and detected modules, expanders to the control panel resources and save settings to the control panel.
5. Complete the system configuration by editing the tabs from "SIM card settings" to "LogicProcessor" depending on system requirements and configuration, save settings to the control panel.
6. Carry out tests and trials, go to the "Online Review" tab to check the system status, among others: failures, operation of inputs, control of outputs, GSM status, temperature measurement, etc.
7. Terminate programming and disconnect the cable from the RS232TTL connector.

Remote configuration: TCP / IP (GPRS).

If the control panel has been configured (APN) and there is known access data, remote configuration via GPRS connection is possible.

The programming requires:

- access to the GPRS network of the control panel SIM card (set APN, password, user),
- remote access option via TCP / IP set,
- the control panel can not be in arming mode (standby), alarm mode,
- knowledge: ID of the control panel, TCP / IP key, communication password with the PC (or file with the control panel configuration),
- service computer with internet access for TCP / IP mode RopamBridge and for TCP / IP mode local server, fixed IP address and open port (default 8081),
- possibility of sending an initiating SMS with the service or main code (see filter, 'SMS control only for numbers from the list').

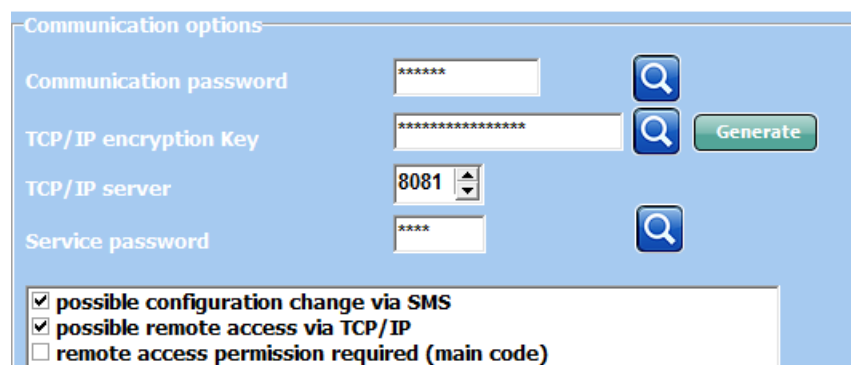
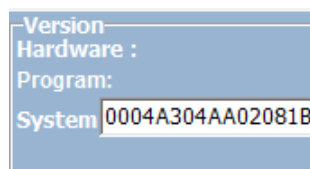

System configuration: TCP / IP AP-IP module.

If the AP-IP module is installed in the system and is connected to the Ethernet or Wifi network, it is possible to program the panel using TCP / IP.

The programming requires:

- access to the network with the AP-IP system and the open port 8882,
- the ability to enter the service mode in the control panel,
- the control panel can not be in armed mode (armed mode),
- knowledge: ID of the control panel, TCP / IP key, communication password with the PC (or file with the control panel configuration),
- TCP / IP remote programming option selected,

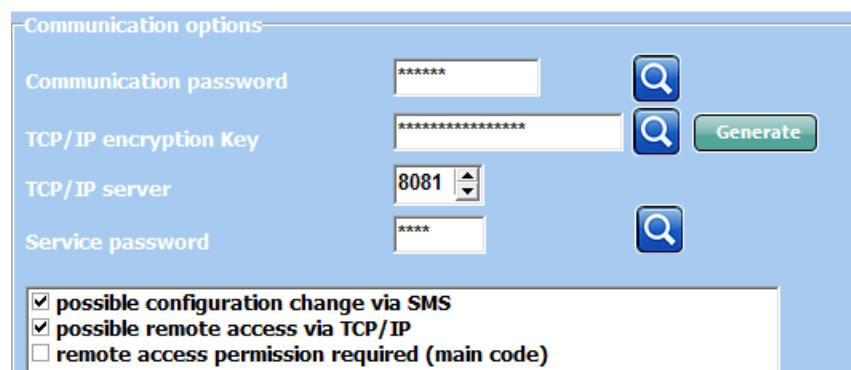
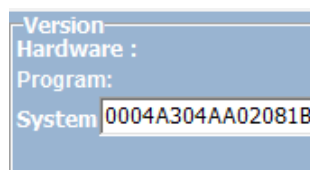

Programming TCP / IP using AP-IP:

- start OptimaGSM Manager, enter the ID of the control panel, TCP / IP key, PC communication password (or open the file with the system configuration),
- select from the connection mode: TCP / IP AP-IP module,



- press the 'antenna' remote connection button (the fourth icon from the left),
- start the control panel service mode during connection attempts (20), if the system does not have a programmed touch panel, then the service mode can be started by placing a jumper on connector X3 (third vertical pair from the edge of the PCB), after programming the jumper should be removed!

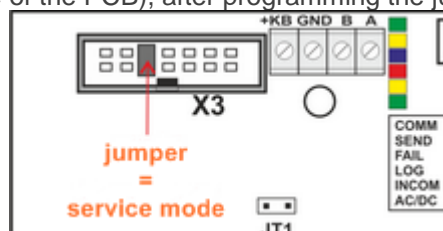

- the OptimaGSM Manager program broadcasts an incoming TCP / IP connection with the control panel ID and usually the connection is established automatically, if the control panel does not respond automatically, the window for entering the control panel IP will be displayed.

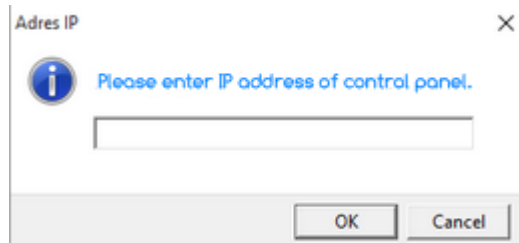

(read IP address for ETH network is possible through: touch panel - user menu, SMS command, on the OptimaGSM bottom bar during the TCP / IP connection set-up, the default IP for WLAN: 192.168.10.1).

Comments:

By default AP-IP has the following settings (in the original configuration of OptimaGSM 1.9 and higher):

- AP-IP module programmed in the control panel configuration,
- configuration of the Wifi option from the OptimaGSM Manager level,
- work modes: Wifi- Access Point with DHCP server (default IP address: https://192.168.10.1)
SSID: apip
WPA2: ropam_optimagsm
- ETH mode of operation: DHCP client,
- TCP / IP key = ID of the control panel (see sticker)
- communication password with PC: 111111

The above settings allow programming through the TCP / IP of the factory OptimaGSM control panel!

Firmware upgrade.

Comments:

Updating the panel, panels or expanders in the system always requires:

- updating all elements to compatible versions,
- identification and programming of the current configuration program, dedicated to the latest versions,
- verification and possibly changes in functions, scripts LogicProcessor,
- verification or deletion and re-creation of system users (codes),

Functional description.

The description of the function and the configuration method is presented by means of windows, descriptions and program messages.

Tab: SIM card settings.

SIM card PIN

In the "SIM card PIN" field, enter the digits of the PIN code of the SIM card installed in the module telephone.

Comments:

- in the factory settings the "SIM card PIN" field is empty. This allows for the installation of a SIM card and start-up of the control panel without fear of blocking the SIM by entering an incorrect PIN code,
- empty "SIM card PIN" field does not disable PIN code request only applies to non-PIN cards.

Access data for APN operators in Poland:

Operator	APN GPRS	APN user	APN password
T-Mobile PL	internet	none (empty field)	none (empty field)
Orange PL	internet	internet	internet
Plus GSM PL	internet	none (empty field)	none (empty field)
Play	internet	none (empty field)	none (empty field)
wRodzinie	wrodzinie.pl	none (empty field)	none (empty field)
Nju Mobile	internet	internet	internet
Heyah	heyah.pl	heyah	heyah

Tab: Zones, phone numbers, e-mail address.

The tab is used to set the input / output parameters for each zone, enter the system users data (max 8). In this field you can also use the option of arming the system to standby with the use of timers.

Tab: Modules, TPR panels.

Touchpad.

Touch panel / options:

Name: allows you to enter a unique name for the touch panel.

A loud alarm in the panel [s]: defines the time of acoustic alarm signaling in a given touch panel. Setting range: 0-9999 [s].

Quick exit possible: the active option allows you to arm the full and night armed mode (inputs with the NIGHT option) without entering the user code.

Exit time signaling: the active option activates the acoustic signaling in a given TP panel during the exit delay.

Enter time signaling: the active option activates acoustic signaling in a given TP panel during entry time.

Acknowledging the keypads: the active option activates the acoustic signaling of pressing the button (detection field).

3 incorrect codes: sabotage output: entering three incorrect codes will activate the sabotage output, counting is independent for each TP panel.

Loss of connection: exiting sabotage: loss of connection (communication) of the control panel, activates the sabotage output.

Tamper housing active: the active option activates the tamper protection of a given TP panel.

Highlighting when the time for enter: the active option causes full panel lighting in time to enter.

Random keyboard buttons: the active option will activate a random numeric keypad layout.

Ask for blocking violated zones: the active option will display a message about blocked zones in the system when the system is armed.

Controlling the outputs requires a code: the active option will require the user to enter the code when entering the function of controlling the outputs.

The relay control requires a code: the active option will require the user to enter the code when entering the relay output control function in a given TP panel.

The blocking of zones requires a code: the active option will require the user to enter the code at the entrance to the function of blocking zones in the system (always), after disarming - the zone blocking is deactivated.

The failure check requires a code: the active option will require the user to enter the code at the entrance to the failure check function (always).

The exit from the screensaver requires a code: the active option will require the user to enter the code when the panel exits the screen saver (always).

Record of temperature readings on the SD card: the function activates the log recording with the temperature measurement on the SD card in the given panel (YYMMDD.txt files).

Alarm signaling with the TSR-1 and AI input: the function activates the alarm signaling when the L, H levels for TEMP1, TEMP2 and AI are exceeded. The signaling in the panels is analogous to that for the alarm inputs but does not generate an alarm in the system (it does not activate the ALARM outputs).

Touch panel / gong:

Input gong: the option allows you to specify the zones that should generate a gong signal in a given TP panel.

Touch panel / output control:

Controlling the outputs: the option allows defining the outputs whose control will be available in the given touch panel. The above option allows you to create simple home automation applications: roller blinds control, garage gates, etc.

Touch panel / backlight from inputs:

Highlight from inputs: this option allows you to specify the zones which are to trigger the full brightness of a given TP panel, exit from the screensaver.

Panel touch / panel status:

During an active connection to the service computer, in the tab; module status, the status of TP1, TP2 touch panels is presented.

Connection: indicates correct or no system connection via EIA485.

Soft: software version (firmware) in a given touch panel.

Hardware: hardware version of a given touch panel.

I1: indicates the resistance value in the circuit (detector) I1 of the given TP panel.

I2: indicates the resistance value in the circuit (detector) I2 of the given TP panel.

Uzas.: value of the supply voltage of a given TP panel (measurement after the protection diode, the voltage value on the terminals is higher + 0.6V).

Tamper: indicates the anti-tampering status of the touch panel.

Temperature: indicates the current temperature value from the sensor built into the touch panel.

EXP-I8 expander.

Local zone expander (8).

Line configuration as in the OptimaGSM central office.

APx-Aero.

Device status window (detectors):

ID: Device number in the controller -> entry number in the system, e.g. ID 1-> I13 ... ID8-> I20 for NeoGSM, ID1-> Ix for OptimaGSM

Type: Aero device type.

Violation: state of the detector, motion detection.

Tamper: state of anti-sabotage circuit.

Slevel: communication level Aero (Excellent / Good / Weak), results from RSSI and LQI parameters.

RSSI: radio signal level (range -20 to -110 dBm).

Note: If there is another transmitter on the 868MHz band nearby, the RSSI reading (background) is lower, for the system it is a disturbance, increased ISM background.

LQI: radio transmission quality, lower value = better quality,

Vbat [V]: battery voltage in the detector, the new battery has 3.5-3.6V.

Note: after installing the new battery reaches its nominal parameters only after about 24 hours of work in the detector, this is due to the battery construction, very low power consumption by the detector, ambient temperature.

Connection with AP: status of communication with the detector.

Sensitivity: sensitivity parameter of the detector detection algorithm.

1: lowest sensitivity

...

8: highest sensitivity

Low sensitivity values also reduce the real detection range. For applications in which animal resistance (PET) is to be used, use parameters 1 to 4.

Pulses: signal analysis time parameter, SmartPIR algorithm.

PULSE 1: the shortest sampling time, signal analysis

... ..

PULSE 4: the longest sampling time, signal analysis

The parameter specifies the sampling time for the SmartPIR algorithm.

Each value allows effective detection, under normal conditions it is recommended to use PULSE 1-2 and for applications in which there may be interference or be resistant to animals (PET) PULSE 3-4.

PetImmunity: the detector has the option of resistance to pets: cats, dogs up to 40 cm high and up to 30 kg and rodents. The detector has a default resistance to animals up to 12 kg. The detector must be mounted to a perpendicular wall relative to the floor, at the nominal height, do not point the detector on the bracket towards the floor. Animals can move around the floor of the protected area. The protected area must not contain furniture, shelves on which animals can move. The detector requires proper configuration regarding sensitivity and time of analysis (Pulse).

Configuration of detectors:

Add new detectors: start learning mode, add new detectors, procedure:

- open the detector and install the battery in the first detector according to the polarity. The detector after setting up the connection with the AP will generate two series of flashes (blue diode) with the device number in the AP (eg address 2 two series of flashes after two flashes),

- repeat point 2 for all detectors, detectors receive system no. According to the order of addition,

- check the status of detectors in the controller (RSSI, LQI), change the configuration for individual detectors, save the settings to detectors from the AP level.

Remove detector no. X: removes the selected detector from the controller's memory, x; 1-8 (currently connected to AP).

Delete all detectors: the function removes all detectors from the controller (currently connected to the AP).

Read the detector settings: the function gets settings from the detectors.

Send sensor settings: the function sends settings to all detectors.

Enable WalkTest: the option starts the test mode in the detectors, motion detection is indicated by the WalkTest diode. The active mode only during programming also causes more frequent than the interval monitoring of Aero devices (RSSI, Vbat) resulting from the interval.

Wireless communication interval: the detector status control interval has three intervals: 30/60/90 s (60s by default). For maximum battery life, select the interval of 90 seconds. **The control interval**

affects how long the AP command will be sent to the detector, including: supervision, WalkTest. All alarms, sabotages are sent without delay to the AP controller.

The detectors automatically control the transmission power, in order to obtain effective communication and for maximum battery life.

Comments:

If the detector / transmitter is not connected to the AP (eg after turning off the AP power supply), the detector goes into the power saving state. **Subsequent attempts to connect and synchronize take place every 10 minutes.** The blue LED indicates a series of 10x flashes every 10 minutes.

Loss of wireless communication (disarmed): the function allows you to select the system's reaction to the loss of connection when the system is not armed (no supervision). The option allows to choose: sabotage (loud alarm) or failure.

In system standby mode (supervision), the loss of Aero connectivity is a sabotage of the system. Signaling after 100 s in accordance with the standard for grade 2.

Comments:

In the ZONES tab, the Aero detectors should be programmed as **2EOL / NC**, supported types: **Normal, Normal, Delayed, Delayed WAR. COUNTING.**

Graph of the RSSI signal level.

A level histogram is available for each detector, distinguishing by color.

PSR-ECO-xx.

System impulse power supply with RopamNET bus and monitoring of power supply and network operation status (loss of power) and battery (charging, charge status, voltage).

Hub-IQPLC-D4M.

The IQPLC building automation system uses SmartPLC technology. It is a unique and innovative approach to communication, changing the electrical installation of the building into a communication bus for monitoring and control. Technology The IQPLC building automation system uses SmartPLC technology. It is a unique and innovative approach to communication, changing the electrical installation of the building into a communication bus for monitoring and control. SmartPLC technology from Ropam Elektronik opens a new chapter in building automation and gives so far unavailable options for designers and integrators. SmartPLC is an innovative and unique two-way communication on the power line NN. The IQPLC system is based on Hub and distributed IO modules (up to 8 in the system).

Hub-IQPLC integrates the OptimaGSM system with distributed "intelligent connectors".

Communication between the hub concentrator is based on the RopamNET bus. However, the communication between the concentrator and the intelligent connector takes place over the low voltage (230VAC) power lines. IOx-IQPLC (IO / IOE) modules have a controlled binary output 10A / 250V and an ON / OFF binary input, potential N / L, to operate the switch or unipolar button. The IOE-IQPLC module also measures the power consumption of the electrical receiver from 1W-2500W, which allows control and diagnosis of the controlled circuit. The modules are designed for mounting in Ø60 flush-mounted boxes (deep) and are compatible with every standard socket and electric connector / button. The scope of SmartPLC communication is virtually unlimited within one power network, low voltage LV building installation. SmartPLC from Ropam Elektronik opens a new chapter in building automation and gives so far unavailable options for designers and integrators. SmartPLC is an innovative and unique two-way communication on the power line NN. The IQPLC system is based on Hub and distributed IO modules (up to 8 in the system). Hub-IQPLC integrates the OptimaGSM system with distributed "intelligent connectors". Communication between the hub concentrator is based on the RopamNET bus.

Hub-IQPLC integrates the OptimaGSM system with distributed "intelligent connectors". Communication between the hub concentrator is based on the RopamNET bus. However, the communication between the concentrator and the intelligent connector takes place over the low voltage (230VAC) power lines. IOx-IQPLC (IO / IOE) modules have a controlled binary output 10A / 250V and an ON / OFF binary input, potential N / L, to operate the switch or unipolar button. The IOE-IQPLC module also measures the power consumption of the electrical receiver from 1W-2500W, which allows control and diagnosis of the controlled circuit. The modules are designed for mounting in Ø60 flush-mounted boxes (deep) and are compatible with every standard socket and electric connector / button. The scope of SmartPLC communication is virtually unlimited within one power network, low voltage LV building installation.

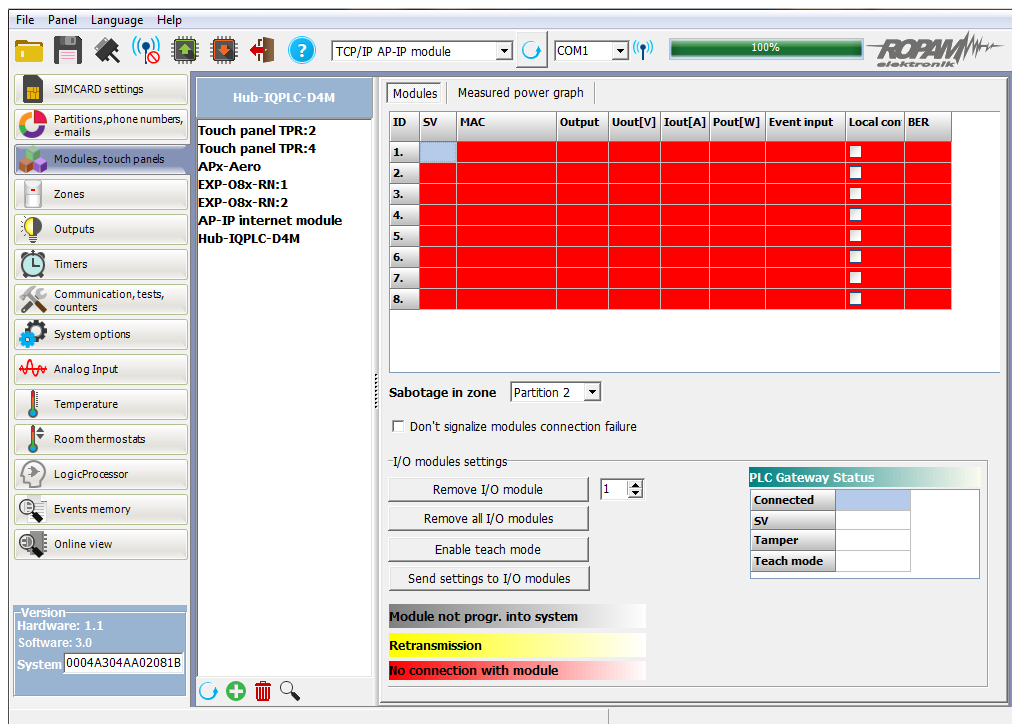

Device status window:

- SV:** firmware version of the connector (module, intelligent socket) IO / IOE.
- MAC:** unique MAC number of a given IO / IOE connector, identifying the connector in a given Hub.
- Output:** controlled switch output status: green = OFF (logic '0'), red = ON (logic '1'). By default, the outputs of the switches are assigned to the outputs: O25-O32. The control of the outputs will be consistent with the configuration of the data outputs and / or LogicProcessor.
- Uout:** AC supply voltage of the given switch (for IOE-IQPLC).
- Iout:** the current flowing through the connector (IOE-IQPC).
- Pout:** power consumed by the receiver controlled by a given connector (applies to IOE-IQPC). The power value can be used in LogicProcessor via variables:

p1+p8	power consumption value from IOE-IQPL [W] modules (smart sockets in the SmartPLC system)	1÷2500
--------------	--	--------

Event entry: state of the input IN of the switch, input status. State of IN inputs can be controlled, used to create control in LogicProcessor via variables:

ev1÷ev8	change of the input state of the IOE / IO-IQPLC connector, takes the value: 0,1,2,	0 = none 1 = button pressed> 30ms 2 = button pressed> 800ms
ip1÷ip8	the input state of the IOE / IO-IQPLC connector, refreshed every communication control interval, assumes a binary value of 0 or 1	0 = switch off 1 = switch on

Local control: selecting this option will cause the IN input of a given switch to control the output in the same module. In this mode, the bell (momentary) should be connected to the IN input.

BER: Bit Error Rate calculated from SmartPLC transmission, test time (interval) to calculate the coefficient is 15 minutes. If the coefficient is below 30 this allows effective communication by SmartPLC. Above this parameter it is necessary to analyze the topology and connections of switches in the 230V network, change the phases on which the switches work, use SmartPLC network coupler, exclude or filter out receivers generating large interferences (eg commutator motors, power supplies without PFC, inverters).

Editing I / O modules:

(Options allow you to manage connectors / I / O modules).

Delete I / O module: removes the indicated module (connector) from the Hub's memory (the I / O module requires a local reset!).

Delete all I / O modules: the function removes all modules (connectors) from the Hub's memory (I / O modules require a local reset!).

Enable / disable learning mode: starts or stops learning mode, adding new I / O modules.

Send settings to I / O modules: the button sends additional settings to the I / O modules, eg local control (connection required with the given I / O).

Status: shows the current status of the Hub.

Programming procedure for I / O modules:

(If Hub-IQPLC is installed in the system, i.e. it has been identified on the bus and the configuration with its presence has been entered into the control panel, it is possible to program the I / O modules)

1. Start the learning mode in the program.
2. Turn on the 230VAC power supply to the first I / O module, the diode in the factory connector is lit with continuous light (from v1.4) or blinks (to v1.3) after establishing connection with the Hub, the MAC number will appear and the line will be highlighted in yellow.
3. Turn on the 230VAC power supply to the next I / O module and wait for the MAC number to appear.

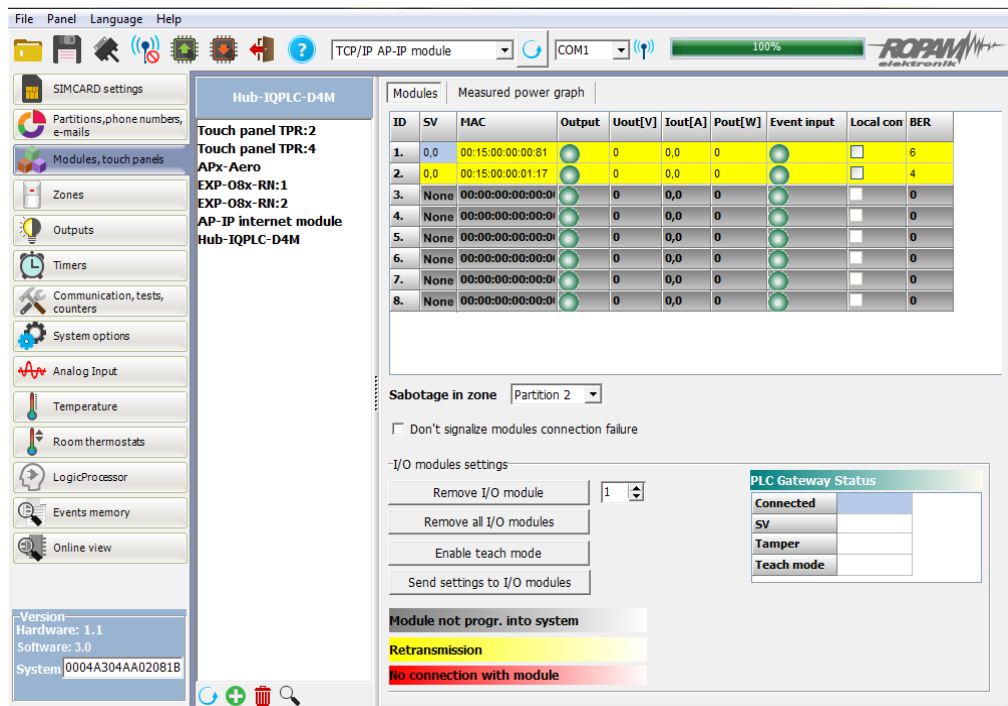

4. After programming the last I / O module, deactivate learning mode, all modules and their status should be visible in the program. The I / O module should blink with its address in the series, e.g. address 1: ON_200ms / OFF_1000ms.
5. If the given I / O module is to have the local control function enabled, select this function and save the settings by pressing 'Send settings to I / O modules'.
6. If all data is correct, save the settings after changes to the control panel.

Reset of I / O modules (switches) to factory settings:

1. If the I / O module has been programmed into the Hub, it can not be programmed to another one and needs to be reset.
2. Reset procedure:
 - turn on the power supply of the I / O module,
 - press and hold the PR button for about 10s. until the LED lights up continuously, then release the PR button and wait about 10s. until the diode blinks (isolated with a 400VAC screwdriver!)
3. The module has reset ID and settings (to factory), is ready for new programming.

LED indication of I / O modules:

state	I / O module to v1.3	I / O module from v1.4
factory	blinks 'fast' ON_200ms / OFF_200ms.	shines constantly
programmed and connected to the Hub	blinks with your address in the series e.g. address 1: ON_200ms / OFF_1000ms.	blinks with your address in the series e.g. address 1: ON_200ms / OFF_1000ms.
programmed and no connection to the Hub	blinks 'fast' ON_200ms / OFF_200ms	blinks 'fast' ON_200ms / OFF_200ms

NOTES: SmartPLC communication is suppressed by:

- typical filters in power strips, induction energy meters, transformers, serial inductors,
- overcurrent breakers (S type), the higher the current, the lower the attenuation (between Hub-IQPLC and the IO / IOE module there can't be more than one "S").

FGR-4 MMS.

The FGR-4 module is an innovative and universal device for cooperation with MGSM 4.0 + / 4.0-PS + modules. It allows you to process four video signals into images in the 'jpg' format and send them via multimedia messages via MMS / email. The solution is based on standard services of GSM operators and does not require any special devices and software. Multimedia messages are delivered to a standard mobile phone and e-mail address of the Customer. Data transmission is based on GPRS technologies, thanks to which large coverage of the country's surface is ensured and it allows for transmission of photos from objects without access to permanent internet and out of reach 3G networks (generally all non-urban areas).

The module also allows local recording of captured images to an SD card, it fulfills the function of the image recorder after detecting movement in the image. The saved archive can be read locally on a computer or remotely via MMS. The universal functions and design of the FGR-4 module makes it possible to use it to control the state of the object, visual verification of alarm events, eg sending a picture from the object after the burglary, fire alarm and unauthorized entry.

COMMENTS:

The system can be PSR / PSR-RF or FGR-4 installed because the modules use the same communication connector!

TRIGGERING MMS SENDING

The tab allows you to specify events in the system that activate the notification action via MMS. You can define independent parameters for each VIDEO signal (CH1-CH4). As the trigger source you can choose:

- I1-I8 module inputs (activation according to the input type, e.g. INFO = each entry violation triggers the action)
- O1-O8 module outputs (activation of the output will trigger an action, e.g. Alarm)
- V1-V2 motion detection

Selecting several sources creates a logical OR condition, the notification will be activated if at least one event occurs.

SEND MMS TO

The tab allows you to specify the recipients of a multimedia message.

TELEPHONE NUMBER - you can specify up to 8 phone numbers (retrieved from the NUMBERS tab)

E-MAIL ADDRESS - you can enter up to 4 e-mail addresses (entered in the FGR-4 tab)

MMS header - a camera description, eg a garden etc., sent together with a photo in an MMS message.

COMMENTS:

the fee for the MMS message is charged for each phone number and e-mail address

MMS OPERATOR

The tab allows you to select the GSM operator of the card installed in the module. The correct selection allows you to establish a GPRS connection and send MMS messages.

COMMENTS:

- some GSM networks require activation of GPRS transmission in BOK
- in the case of prepaid SIM cards, lack of funds is not signaled by the network (GPRS transmission), the correct transmission "MMS sent" will be saved in the module's memory, although the MMS message will not reach the recipient

OPTIONS

Signaling problems and failures:

MMS TRANSMISSION ERROR = SMS NOTIFICATION - if the option is selected, the correct MMS (GPRS) transmission will be sent to the first telephone number;

VIDEO LOSS - after selecting the option, the lack of VIDEO signal on one of CH1-CH4 inputs will be signaled like sabotage of the 2EOL / NC line (alarm, output control, etc.)

PHOTO sequence (AS FOR CH1) - the option allows you to send up to 4 photos in one MMS. In the sequence, up to four video channels can be selected and the time of creating images from the moment of triggering. Sequence will be triggered as for channel CH1 (skipping several events = logical OR).

HiRes MODE (704x544) CH1 only - CH1 channel mode in 704x544 resolution mode, only one image in MMS, no sequence. (requires FGR-4 v1.3!)

IMAGE QUALITY% - allows you to specify the compression ratio (JPG). The factory parameter is set to 50%. The size of the file from the photo depends on the degree of compression:

40% = 18kB (for a color photo)

90% = 47kB (for a color photo)

The compression option allows you to optimize the size of MMS messages. In the NeoGSM, the MMS limit is 300kB.

MMS COUNTER - this option allows you to limit the number of MMS messages sent. The counter is reset every 24h (factory 10).

MMS LOCK - the option allows setting the blocking time for sending next MMS from a given input (in minutes). This option allows you to reduce costs when, for example, you start the detection of the VIDEO as the trigger source of the notification.

DETECTION SENSITIVITY - sensitivity parameter of motion detection (for all inputs), minimum sensitivity: 1, maximum sensitivity: 15.

MODULE STATUS - the tab allows you to test and view the status of the on-line module (during connection with the PC).

COMMENTS:

- in case of exceeding the value of 100kB, the module removes the last photo (photos) from the message

- the maximum waiting time for the correct GPRS transmission by the module is 120s.

- GPRS transmission time (100kB) depends on the GPRS load and range (approx. 30s)

- GPRS transmission has the lowest priority in the system, if at the same time another notification occurs: SMS or VOICE the order is: SMS-> VOICE-> MMS

RF-4.

Configuration of channels (pilots).

- **Button (A) / (B) / (C) / (D)**: select the action in the system for a particular channel. Options: no function, on / off full standby, on / off night watch, armed on, night watch, off waking / alarm, panic loud.

- **SMS on / SMS off**; enter the message content for a particular event, e.g. for start / stop. full armed mode, you can enter **SMS on / SMS off**. and for the full armed system you can enter: SMS on, etc.

- **Add pilot's number**: selecting the function adds to the content of the SMS the number of the pilot who generated the event.

- **Send an SMS to:** the matrix allows you to specify phone numbers to which SMS messages will be sent.
- **RF-4 status:** during the connection with the control panel in the programming mode, status view is available: connection status, HV version (hardware version), SV version (software version), Uzas supply voltage, pilot number (during transmission), status remote control battery, outputs O1-O4.
- **RF-4 programming: entering the radio control programming mode (during connection with the control panel by RopamNET).**

Remote controls:

- **Add a new remote for 10s. :** function generates a 10s window. for programming new pilots in the system, press any button of the new remote control, which is in the RF-4 range. The pilot will be saved in the lowest free number. At the end of the programming window, you can check the number of the remote control in the **Status tab RF-4**.
- **Delete remote control no .:** the function removes from the memory the remote control with the indicated number.
- **Delete all remotes:** the function removes **all** remotes from the memory.

RF-4 output settings:

- **Output work type / Run time [s]:** the option allows you to choose the type of work output from the given channels in the programmed remote controls:

Monostable: the output will be activated after activating the channel for the duration of operation [1-255 p.].

Bistable: the output will be activated after the channel activation and will remain active until the next activation (step by step ON-OFF-ON ..)

Real: the output will be activated after activating the channel and will remain active as long as the transmission is in progress (pressing a given button on the remote control).

Disabled: the output will not change the state from activation of a given channel in the pilot, eg only the RopamNET bus is used.

Save the RF-4 configuration: save the settings to the RF-4 memory.

Finish the prog. RF-4: termination of RF-4 programming mode and return to RF-4 configuration in the system.

EXP-I8-RN.

The system may have two EXP-I8-RN-xx series expanders.

The address of the given EXP-I8-RN-xx. is determined by the first DS1 switch:

1: OFF = address 1

1: ON = address 2.

EXP-O8x-RN (EXP-O8R-RN or EXP-O8T-RN).

The system may have two EXP-O8x-RN-xx output expanders.

The address of the given EXP-O8x-RN is determined by the first switch DS1:

1: OFF = address 1

1: ON = address 2.

AP-IP

The AP-IP module settings window:

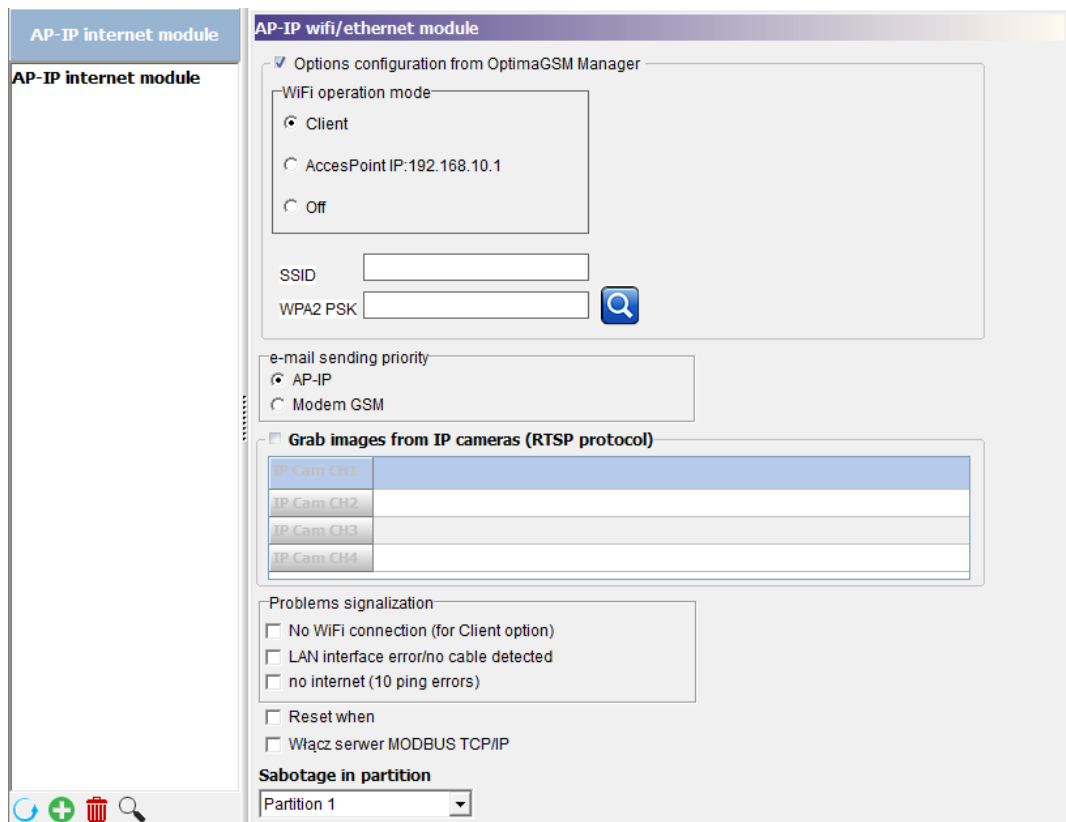

Tab: Inputs.

• Polarization:

Module inputs can be independently configured in one of the polarization types (configuration):
I1-I6: NO, NC, EOL, 2EOL / NO, 2EOL / NC, OFF I7-I8: NO, NC triggering by "ground" (GND) or "plus" (+ VDC) depending on the setting of JI7, JI8.

NO - means the input in the NORMALLY OPEN configuration, triggered by the "ground" (GND). In the case of I7 and I8 inputs it is possible to trigger with "ground" (GND) or "plus" (+ VDC) depending on the setting of JI7, JI8.

NC - means the input in the NORMALLY CLOSED configuration, triggered by disconnection from "ground" (GND). In the case of I7 and I8 inputs it is possible to trigger with "ground" (GND) or "plus" (+ VDC) depending on the setting of JI7, JI8.

EOL - means the input in the PARAMETRIC configuration (one parametric resistor), is triggered by disconnecting the parametric resistor 2.2 k Ω , the resistor must be connected between the input and the system ground.

2EOL / NO - means the input in the configuration: two-parameter, the NO detector, the detector circuit is closed with two 1.1 kΩ resistors. The 2EOL zones of this type enable the control panel to simultaneously control the state of the detector and its tamper contact.

2EOL / NC - means the input in the configuration: two-parameter, the NC detector, the detector circuit is closed with two 1.1 kΩ resistors. The 2EOL zones of this type enable the control panel to simultaneously control the state of the detector and its tamper contact.

DISABLED - disables the input regardless of other input settings.

• **TYPE:**

INFO - activation of the zone does not trigger an alarm action, but starts the process of sending SMSes and VOICE voice calls according to the settings.

24h - the zone generates a tamper alarm, in each state of the control panel and generates a process of sending text messages and VOICE voice calls according to the settings.

Normal - the line triggers an alarm (loud) if the system is in armed mode and generates the process of sending text messages and VOICE voice calls according to the settings.

ON / OFF - the system arming / disarming line. The input can work in bistable mode (switch): violation activates the system, the end of the violation turns off.

or monostable (button, when the option: PULSION LINE) is enabled, the action is then: the first violation is arming the module, the second violation disarms, alternately. Allocating the entrance to the night zone generates ONLY night standby and global disablement.

DELAYED - the line triggers a loud alarm after violation and after the entry delay time has elapsed in the absence of disarming the system (during this time). The time for entry is set in the OPTIONS tab.

DELAYED WAR - the line triggers an alarm, SMS and ringing after the entry delay and no disarming have elapsed if the DELAYED zone was violated in the first place. Otherwise, it works as a USUAL NORMAL. The global time for input is set in the OPTIONS tab.

COUNTER - violation of this type of line will increase the counter of violations, reaching the value of the counter will start alarming actions. The line is active during the module standby time (as Normal), the line violation counter is reset after a specified period of time has elapsed since the last violation.

CLEARING ALARM - violation of the zone only cancels the loud alarm without affecting the system arming.

REGRET. ARMED - violation of the zone will only arm the system (supervision). Allocating the entrance to the night zone generates ONLY night standby and global disablement.

OFF. ARMED - violation of the zone only disarms the system (supervision) and, if necessary, clears the loud alarm if it was in the system.

NORMAL SILENCE - the zone only works in armed mode, does not generate a loud alarm, it only generates the process of sending SMSes and VOICE voice calls according to the settings.

• **TIME:**

The parameter specifies the time in ms. (1s = 1000ms) through which the input must be violated so that a change in its status can be detected. For each of the inputs, you can set the reaction time independently (by default set to 500ms). Time min / max = 250ms / 60s.

• **Block to [min]:**

Entry time (reaction) time after the first violation. The option works for the TYPES: INFO, NORMAL, NORMALLY QUIET, DELAYED, LATE DELAYED. For each of the inputs, you can set the lock time independently (by default set to 0s). Min / max time = 1min / 360min.

Warning:

- the option is used for limiting the number of notifications and for motion detectors connected to inputs; limiting the number of transmissions from a given source, readability of sent messages,

- for motion detectors, eg PIR, the parameter should be the duration of a loud alarm or a minimum of 1 minute.

• **VSR message:**

The column is used to configure the content of voice messages played when the input is violated in cooperation with the VSR-2 voice synthesizer.

Enter the characters corresponding to the numbers of the recorded voice messages and / or eavesdropping of the object:

- messages: 0,1,2,3,4,5,6,7,8,9, A, B, C, D, E, F

(maximum message time: 0-7 = 16s. 8-F = 8s.)

- audio module (microphone): m

It is possible to sum the content of the message by entering several characters (up to five characters) separated by a comma, messages will be played in the order in which they are listed in the tab.

Each input can be configured independently.

• **Night line:**

The column allows you to create a "night" zone from selected zones. The zones marked in the column will be armed when the night armed mode is armed.

• **3 alarms:**

Inputs with the option selected will generate a maximum of three transmissions, alarms during one arm. The third violation will block further reactions.

Tab: Inputs - notification.

• **SMS VIOLATION / SMS RETURN:**

In the tab we enter the content of SMSs that will be sent on events. It is possible to send independent SMSs when the entry is violated and returned. The maximum length of the SMS is 20 characters. It is not allowed to use special characters (eg Polish letters).

• **FLASH:**

Specifies whether the sent SMS should be displayed directly on the phone's display (flash) or read from the inbox. Checking the option configures the SMS type for INFRINGEMENT and RETURN entry.

COMMENTS:

- please note that a FLASH SMS message can be easily overlooked because it is not memorized in the phone (it disappears from the phone's display, eg when someone is calling) the FLASH option may not work when sending SMSs to a different operator than the SIM card of the module (this is not dependent on the settings but results from restrictions introduced by the operators!).

Tab: Inputs - options.

• **ZONES OPTIONS**

- **METER TYPE LINE OPTIONS**

Configures the Counter type input: number of violations and resetting time of the violation counter (p.)

- **OPTIONS ARM/DISARM**

Selecting the PULSED LINE option causes the control of the armed mode as a "button": the first violation activates the system, the second disarms, etc.

(no check = control of armed mode as "switch": violation of the zone: arming the system will return to normal state: disables the partition)

Selecting the CLEAR E-MAIL option will end the SMS and VOICE notification at the time of disarming / alarm, regardless of the progress of the notification action!

Tab: Outputs.

POLARIZATION

The choice of configuration in the normal state:

- open NO or shorted NC to the "plus" of the module: output O1, O2
- open NO or shorted NC to the "mass" of the module: output O3-O8

Comments:

For O1 or O2, the 'NC' polarity setting and no control, empty 'on by' option turns O1 or O2 into a power output with parameters like AUX.

ACTION

MONO (monostable, one stable state) the output changes its normal state after the event marked in the "On by" box for the time specified in the "Time [s]" field, after its expiry returns to the normal state. It is possible to shorten the MONO time by means of the SMS Off or DTMF Off commands.

BI (bistable, two stable states) the output changes the normal state after the event marked in the field "Switched by" to the opposite state and remains in it until the next event, eg violation of the input, control from the touch panel. The output in BI mode for triggering as an ALARM acts as a latch (latch) to reset the alarm.

TIME [s]

It defines the operation time [s] of the output in the MONO mode, parameter 1-9000 s.

SMS ON

In the tab, enter the content of the SMS which will activate the output (default OnX where X = the number of the output). The maximum length of the SMS is 20 characters. It is not allowed to use special characters (eg Polish letters).

SMS OFF

In the tab, enter the content of the SMS which will disable the given output (by default OffX where X = the number of the output). The maximum length of the SMS is 20 characters. It is not allowed to use special characters (eg Polish letters).

REQUIRED THE CODE

Selecting this option will cause that controlling the given output via SMS will require the content to be placed in addition to SMS ON / SMS OFF, ACCESS CODE (OPTIONS tab).

DTMF On

In the tab, enter the DTMF code, which will activate the given output (DTMFOn *). recommended length 2-4 characters (numbers).

ANNOUNCED THROUGH

It defines which events control the output, selecting several options creates the LOGICAL SUM (OR) of these events (ie the output is active when at least one event has been met), this allows for combining, for example, control: simultaneously SMS and CLIP.

SMS checking the option allows you to control the output via SMS (command or command + access code depending on the configuration).

CLIP option allows you to control the output by short connection to the module telephone number. The function is available under the condition of allowing the control in the option "NUMBERS AUTHORIZED TO CONTROL CLIP by selected numbers entered in the fields PHONE NUMBERS or any number. In addition, it is possible to determine the response of the module to an incoming call, using the option INCOMING CALLS.

ALARM output active when an alarm occurs. (def. usual entrance).

STANDBY active output (indicator) in the armed state when the module completes the exit delay countdown, if this option is active, the time settings in the "TIME [s]" field are ignored.

ENTRY TIME active output when the module counts down the entry delay time. (Def. Input on / off, delayed).

OUTPUT TIME output active when the module counts down the exit time.

ACKNOWLEDGMENT ON / OFF The option enables acknowledgment of module arming / disarming.

- arming with 1 signal (1x 0.5s.),
- disarming with two signals (2x 0.5s.),
- arming with violated zones (detectors) 5 signals (5x 0.5s.),
- arming system sabotage (detectors) of 10 signals (10x 0.5s.),
- information on remote arming can be sent via SMS to selected telephone numbers.

Clearing the alarm can also delete any notification action; SMS, SMS + VOICE, VOICE (service).

FAILURE active output when a failure occurs.

NO AC output active when AC power loss occurs AC delay signaling time (0s-1000min configurable in the OPTIONS tab)

TAMPERED output active when sabotage of the 2EOL / NC, 2EOL / NO line or devices with tamper protection eg panels.

TIMER x output controlled by the selected timer (on / off, see OPTIONS-> Options 2).

DTMF selecting this option allows you to control the output via DTMF during a voice call (DTMFOn * or DTMFOff *).

JAMMING active output when the control panel detects jamming of the GSM signal (no GSM network), it is possible to work as an indicator during the whole jamming time (BI) or work for a limited MONO time. Reporting on the output allows you to send information by a different way of communication about jamming or siren, loud alarm.

COMMENTS:

- control of outputs by temperatures T1, T2 and AI has a higher priority than 'switched on', thermostat output or AI can be triggered from other sources, e.g. SMS but if the condition of the two-state controller is triggered, the given output can only turn off the control cycle, eg return temperature to a value below the threshold.
- LogicProcessor should be used for advanced controls and monitoring.

CLIP CONTROL PHONES (KEYGSM)

The option, when selected, entitles the phone numbers entered in the NUMBERS tab to control the output with the ON: THROT: CLIP option selected.

If you select EVERYONE, the module will control the output when connecting from any number from the network.

COMMENTS:

- remember that the telephone number from which you want to control the output can not be "restricted".
- reactions to an incoming call are configured in the OPTIONS tab.

Tab: Outputs - notifications.

The tab allows configuration of notifications when the control panel status changes.

Logic state '0' = inactive output:

- polarization of 'NO'

O1-O2 = hiZ (high impedance)

O2-O8 = hiZ (high impedance)

- 'NC' polarization

O1-O2 = + 12V

O2-O8 = GND (ground)

Logic state '1' = active output

- 'NO' polarization

O1-O2 = + 12V

O2-O8 = GND (ground)

- 'NC' polarization

O1-O2 = hiZ (high impedance)

O2-O8 = hiZ (high impedance)

COMMENTS;

- using this tab, select the options in the OPTIONS tab -> OPTIONS 2-> 'do not confirm by SMS control outputs', otherwise the information will be duplicated, i.e. confirmation of the SMS command execution and change of the output status will be executed.

No. OUT1-OUT8; list of outputs to which the settings relate.

SMS 0-> 1; column to enter the content of SMSes sent when the given output changes to the active state '1'.

SMS 1-> 0; column to enter the content of SMSes sent when the given output changes to the state '0' inactive.

CALL 0-> 1; column for activating a voice call (CLIP or voice message) when the given output is changed to '1' active.

VSR 0-> 1; column for entering the numbers of messages played during a voice call from the VSR-2 synthesizer, when the given output is changed to '1' active.

CALL 1-> 0; column for activating the voice call (CLIP or voice message) when the given output changes to the state '0' inactive.

VSR 1-> 0; column for entering the numbers of messages played during a voice call from the VSR-2 synthesizer, when the given output changes to the state '0' inactive.

Tel / email; columns for selecting SMS / CALL / E-MAIL recipients.

COMMENTS;

- no SMS content = no SMS transmission at a given event.

Tab: LogicProcessor.

Examples of the LogicProcessor configuration can be found in the application notes on the installation CD or at the following website: <https://ropam.com.pl/pl/aplikacjeo.html>.

LogicProcessor:

- advanced logic functions, arithmetic functions, counters, time relays,
- up to 20 independent logic conditions, (If ... Then ... Else blocks),

- 20 time relays for the implementation of time-logic functions,
- logic wizard or script editor (scripting language C), simulator: a setter and script preview,

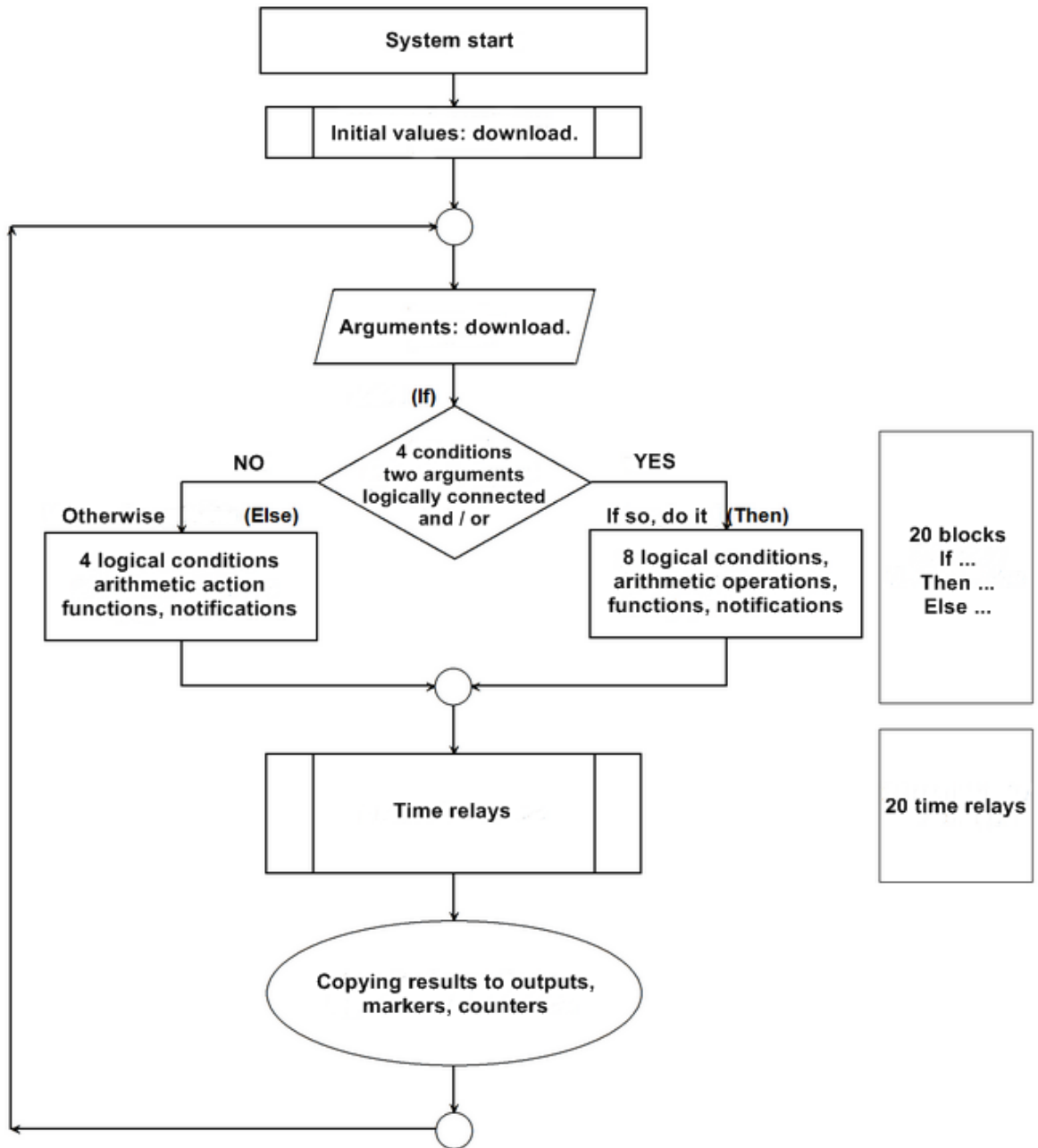

LogicProcessor, functions are executed in a loop according to the scheme.

After the restart, the initial values are taken (optional).

Then the script retrieves the argument data.

Then, up to 20 blocks are executed: **If ... Do this ... Otherwise (If ... Then ... Else).**

The "If" condition is a maximum of 8 conditions between two arguments, each line is related to the logic 'and / or' (AND / OR) with the next.

If the 'If' condition is met, 'Then' block is executed, otherwise 'Else'.

"Then do (Then)" condition is a maximum of 8 logical, arithmetic or panel notifications (Print = information window on the TPR-1x / TPR-4x panel, HINT = lower bar, or SMS).

"Otherwise (Else)" condition has a maximum of 4 conditional functions if the 'If' condition is not met. Then, up to 20 time relays are performed.

At the end of the loop, the results are transcribed to physical outputs, markers, and counters.

Comments:

Functions are performed in a loop according to the scheme. The physical outputs used (function results) in the LogicProcessor must have the "LogicProcessor" control selected.

Logic functions.

Arguments		
Symbol	Description	Value
I1÷I48	status of inputs, assumes a binary value of 0 or 1,	0 = entry intact 1 = input violated
O1÷O32	status of physical outputs, assumes a binary value of 0 or 1	0 = inactive output 1 = active output
tk1÷tk4	timers / calendars, takes on a binary value of 0 or 1	1 = timer on (ON-> OFF) 0 = timer off (OFF-> ON).
vi1÷vi4	the video signal indicator for FGR-4 (CH1 ÷ CH4), assumes a binary value of 0 or 1	0 = no video signal 1 = video signal correct
mv1÷mv4	motion detection in the video signal (FGR-4), assumes a binary value of 0 or 1	0 = no motion detection 1 = motion detected
ac	the primary supply voltage (AC) error indicator, it assumes a binary value of 0 or 1	0 = basic voltage present 1 = basic voltage absent
bf	Emergency battery failure indicator, the headquarters taken from the supervised power supply, assumes a binary value of 0 or 1,	0 = no failure 1 = battery failure
uzv	value of DC power supply voltage [mV]	xxxx
uzi	current value at the output PSR-ECO [mA]	xxxx
log	the modem login indicator to the GSM network, assumes a binary value of 0 or 1	0 = modem not logged in to the GSM network 1 = modem logged into the GSM network
jmg	GSM jamming indicator, adopts a binary value of 0 or 1	0 = no GSM jamming 1 = GSM network jamming
nlv	GSM network level 1-4, so-called 'Stroke'	1÷4
tha1-tha4	temperature indicator for threshold A if the selected mode H, assumes a binary value of 0 or 1	1 = temp.> H 0 = temp <(H-hysteresis)
tla1-tla4	temperature indicator for threshold A if the selected mode L, assumes a binary value of 0 or 1	1 = temp. <L 0 = temp> (L + hysteresis)
thb1-thb4	temperature indicator for threshold B if the selected mode H, assumes a binary value of 0 or 1	1 = temp.> H 0 = temp <(H-hysteresis)
tlb1-tlb4	temperature indicator for threshold B if the selected mode L, assumes a binary value of 0 or 1	1 = temp. <L 0 = temp> (L + hysteresis)

t1v÷t4v	temperature value from sensors T1-T4, interval of measurement every 60s, value [° C], integer with sign	xxxx
ft1÷ft4	temperature sensor failure indicator, assumes a binary value of 0 or 1	0 = no failure 1 = temp sensor failure
ail	analog input value indicator AI for threshold L, assumes a binary value of 0 or 1	1 = (ail < L) 0 = [ail > (L + hysteresis)]
aih	analog input value indicator AI for threshold H, assumes a binary value of 0 or 1	1 = (a and h > H) 0 = [a and h < (H-hysteresis)]
M1÷M16	the value of the markers assumes a binary value of 0 or 1	0 = marker value 0 1 = marker value 1
L1÷L8	counters of integer values, 8 independent counters	-2 147 483 648 ÷ 2 147 483 647
as1÷as4	the full armed indicator in the system for a given zone, assumes a binary value of 0 or 1,	0 = no full mode (supervision) 1 = full standby (supervision)
an1÷an4	the night standby indicator in the system for a given zone, assumes a binary value of 0 or 1, a Binary Value type object	0 = no armed mode (supervision) 1 = night watch (supervision)
al1÷al4	the alarm indicator in a given zone, assumes a binary value of 0 or 1,	0 = no alarm 1 = alarm condition
ta1÷ta4	the sabotage indicator in a given zone, assumes a binary value of 0 or 1,	0 = no sabotage 1 = sabotage condition
fn1÷fn4	the status of relay outputs in touch panels with the addresses TP1-TP4, assumes a binary value of 0 or 1,	0 = inactive output 1 = active output
uid	ID number of user code 1-32 entered in the panel,	1÷32
abf	the low voltage indicator of any registered radio device in the system: Aero, RF-4, assumes a binary value of 0 or 1	0 = no failure 1 = battery failure in the RF device
alf	the indicator of wireless connection loss in the Aero system, assumes a binary value of 0 or 1	0 = wireless connection Aero 1 = no Aero connection
sec	operation time of the control panel [s] since the restart, accuracy 1%	sec= xx
fcd	failure code xx (see SMS STATUS)	00 = no failure xx = failure
aiv	value of analogue input voltage AI [mV]	xxxx
p1÷p8	power consumption value from IOE-IQPL [W] modules (smart sockets in the SmartPLC system)	1÷2500
ev1÷ev8	change of the input state of the IOE / IO-IQPLC connector, takes the value: 0,1,2,	0 = none 1 = button pressed > 30ms 2 = button pressed > 800ms
ip1÷ip8	the input state of the IOE / IO-IQPLC connector, refreshed every communication control interval, assumes a binary value of 0 or 1	0 = switch off 1 = switch on
kb1÷kb5	the number of the active pilot channel (RF-4 module, Keyfob-Aero), assumes a binary value of 0 or 1	0 = pilot channel (button) inactive 1 = remote control channel (button) active (suitable)
kfi	number of active module pilot (RF-4, Keyfob-Aero)	1÷42: RF-4 1-16: Keyfob Aero
ctr	connection status with the MSR-1 monitoring station	"0" - no connection

		"1" - active connection
tr1, tr2	thermostat activation indicator	"0" - heating off, "1" - heating on
0	binary value 0, Binary Value type object	0
1	binary value 1	1

Logic function (If)		
Symbol	Description	Name
==	returns true if both arguments have the same value.	equality
!=	returns true if both arguments have different values	inequality
_ 	returns true if both arguments have a rising edge	equality; rising edge
-- 	returns true if both arguments have a falling edge	equality; falling edge
>	returns the truth if the left argument has a greater value than the right one	bigger than
<	returns true if the left argument has a lower value than the right one	smaller than
>=	returns true if the left argument has a greater or equal right value	greater or equal
<=	returns true if the left argument has less than or equal to the right value	less or equal

Result (Output)		
Symbol	Description	Logical values
O1÷O32	the status of physical outputs, assumes a binary value of 0 or 1	0 = inactive output 1 = active output
M1÷M16	the value of the markers assumes a binary value of 0 or 1	0 = marker value 0 1 = marker value 1
L1÷L8	counters of integer values, 8 independent counters	-2 147 483 648 ÷ 2 147 483 647

Logic function, arithmetic, notifications. (Then, Else).		
Symbol	Description	Table of truth
AND	logical product: A1 ÷ A8 it is a logic that performs the following functions: the '1' signal appears on the output if and only if all n input signals have a logical value of '1'	A1
		0
		0
		1

OR	logical sum: $A1 \div A8$ it is a logic sum system that gives the output a '1' signal if this value has at least one of the signals. This means that '0' appears if and only if both signals are '0'	A1		
		0		
		0		
		1		
		1		
NAND	negated logical product (NOT AND): $A1 \div A8$ it is a logic sum system that outputs '1' when this value has n-1 input signals. This means that '0' appears if and only if all signals are '1'	A1		
		0		
		0		
		1		
		1		
NOR	negated logical sum (NOT OR); $A1 A8 \div$ it is a logic that performs the following functions: the '1' signal appears on the output if and only if all n input signals have a logical value of '0'	A1		
		0		
		0		
		1		
		1		
XOR	an exclusion alternative: $A1 \div A8$ this is the circuit on which the '1' signal appears, if and only if one of the input signals has '1'. In case when the signals are equal to '0' or more than one the value '1' on the output the signal will be '0'.	A1		
		0		
		0		
		1		
		1		
NOT	negation: A1 this is the circuit on which the '1' signal appears, if and only if the input has a '0' signal, if '1' appears on the input, the output has '0'	A1		
		0		
		1		
=	assignment; A1 it is a system that rewrites the value of the input signal to the output	A1		
		0		
		1		
-- 	falling edge: A1 it is a system that will generate on the output '1' if and only if the input changes state '1' to '0'	A1		
		1->0		
		1		
		0		
_ 	rising edge: A1 it is a system that will generate on the output '1' if and only if the input changes state '0' to '1'	A1		
		0->1		
		1		
		0		
+	adding: $A1 \div A2$ the function adds arguments and writes the result to the Lx counter			
-	subtraction: $A1 \div A2$ the function subtracts the arguments and writes the result to the Lx counter			
/	Division: $A1 \div A2$ function divides two arguments and writes the result to the Lx counter			
*	multiplication: $A1 \div A2$ function multiplies two arguments and writes the result to the Lx counter			

%	the remainder of division of two integers (modulo) the function returns the remainder of the division of two integers and writes the value to the Lx counter	
WAIT	wait: A1 the function stops the loop for the time of the [ms] argument or the given value	
PRINT	display information: A1 ÷ A2 function displays a window with information on touch panels, as argument A1, you can enter info text and argument A2 another system argument, eg power, the function will connect A1 and A2	
HINT	display information on the bar: A1 ÷ A2 function displays information on the bottom bar of touch panels, as argument A1 you can enter info text and argument A2, another system argument, eg power, the function will connect A1 and A2	
SMS	send an SMS: A1 ÷ A2 function generates SMS to indicated numbers, as A1 argument you can enter text and phone numbers in the form '\$ 1,2,3,4,5,6,7,8' and argument A2 other system argument, eg power, function will connect A1 and A2	

Name of the function	PRINT					
Destiny	The function prints a given message on the TPR panel window. A window is created where messages are displayed along with their time of occurrence. The window has a history of the last 7 entries. Recent entries replace the older ones.					
Syntax	PRINT (string, x) or PRINT (string) <ul style="list-style-type: none"> • The inscription covered by the text "text to be displayed max. 20 characters • x additional parameter of the variable to be displayed at the end of the text string 					
An example from the wizard	No.	Result to	Function	A1	A2	A3
	1	---	PRINT	Input 1 state	I1	---
Script example	<i>PRINT("Input 1 state",I1);</i>					
Comments	In order for the TPR panel to display PRINT messages from the control panel, select the option Display info from LogicProcessor <input checked="" type="checkbox"/> in the configuration settings of the TPR panel					

Name of the function	HINT					
Destinz	The function prints a given message on the bottom of the TPR panel. The displayed text is not remembered, the next HINT () call or other system message will overwrite the displayed message.					
Syntax	HINT (string, x) or HINT (string) <ul style="list-style-type: none"> • The inscription covered by the text "text to be displayed max. 20 characters • x additional parameter of the variable to be displayed at the end of the text string 					

An example from the logic wizard	No.	Result to	Function	A1	A2	A3
	1	---	HINT	Power supply of the control panel in mV	uzv	---
Script example	HINT("Power supply of the control panel in mV ",uzv); HINT("Failure of LED lighting ");					
Comments	<p>In order for the TPR panel to display HINT messages from the control panel, select the option</p> <p>Display info from LogicProcessor <input checked="" type="checkbox"/></p> <p>in the configuration settings of the TPR panel</p>					

The name of the function	SMS					
Destiy	The function sends a text message with any content to a specific group of recipients.					
Syntax	<p>SMS (string, x)</p> <ul style="list-style-type: none"> • the inscription covered by the characters " text message • x additional parameter of the variable to be added at the end of the text message sent <p>There are several variants of calling a function eg</p> <ol style="list-style-type: none"> 1. SMS ("Too high humidity") sends a text message to the 1st preset number 2. SMS ("Too high humidity \$ 2.3") send 2 text messages to programmed number 2 and number 3 sign \$ separates content from recipients numbers 3. SMS (For a high humidity of \$ 2.3 ", aiv) as in point 2, additionally the value of variable aiv (value of the measured voltage at the AI input) will be added 					
An example from the logic wizard	No.	Result to	Function	A1	A2	A3
	1	---	SMS	Alarm, high humidity	aiv	---
Sample script	<pre> One time sending a text message when the voltage value at the analog input AI exceeds 5V int aiv; int M1; main () { while (1) { AIV = Getai (1); if (AIV> 5000 && M1 == 0) { SMS ("Alarm, high humidity", aiv); M1 = 1; }; }; }; </pre>					

The name of the function	WAIT(x)					
Destiny	The function stops the program execution for a given number of ms (1000ms = 1s)					
Syntax	WAIT (x) x delay in ms					

An example from the logic wizard	No.	Result to	Function	A1	A2
	1	---	WAIT	1000	---
Script example	<p><i>Cyclic switching on / off of the O8 1s / 0.5s output when the 1st zone is armed</i></p> <pre> int as1; main () { while (1) { gbenv (); if (as1 == 1) { Seto (8.1); WAIT (1000); Seto (8.0); WAIT (500); }; }; }; </pre>				
Comments	<p>The function blocks execution of the script for a given time, if it is unacceptable, use time relays that do not block the execution of the script (they operate asynchronously).</p>				

The name of the function	ARMF(x)				
Destiny	The function arms the set zone in full armed mode				
Syntax	ARMF (x) x- number of armed zone 1-4				
An example from the logic wizard	No.	Result to	Function	A1	A2
	1	---	ARMF	1	---
Script example	<p><i>Automatic arming / disarming of zone 3 when zones 1 and 2 are armed</i></p> <pre> int as1; int as2; int as3; main () { while (1) { gbenv (); if (as1 == 1 && as2 == 1) { if (as3 == 0) { ARMF (3); }; } else { if (as3 == 1) { DISARM (3); }; }; }; }; </pre>				

Comments	Available from the v1.8 version of the control panel
----------	--

Name of the function	DISARM(x)				
Destiny	The function disarms the zone in full armed mode				
Syntax	DISARM (x) x- number of disarmed zone 1-4				
An example from the logic wizard	Lp	Wynik do	Funkcja	A1	A2
	1	---	ARMF	1	---
Script example	<i>Automatic disarming of zone 1 when zones 1 and 2 are armed</i> <pre> int as1; int as2; int as3; main () { while (1) { gbenv (); if (as1 == 1 && as2 == 1) { if (as3 == 0) { ARMF (3); }; } else { if (as3 == 1) { DISARM (3); }; }; }; } </pre>				
Comments	Available from the v1.8 version of the control panel				

Name of the function	ARMN(x)				
Destiny	The function arms the set zone in the night armed mode (only zones with the flag night watch are active)				
Syntax	ARMIN (x) x- partition number zone 1-4				
An example from the logic wizard	No.	Result to	Function	A1	
	1	---	ARMN	1	
Script example					
Comments	Available from the v1.8 version of the control panel				

Name of the function	seto(x,y)				
Destiny	Function that sets the given control panel output				
Syntax	Seto (x, y) • x number of the output to be switched on / off • y logical value 1 = output switched on 0 = output switched off				

An example from the logic wizard	No.	Result to	Function	A1
	1	O1	=	TK1
Script example	Activation of O1 output according to the Timer 1 state <pre>int O1; int tk1; main () { while (1) { gbenv (); O1 = TK1; Seto (1, O1); }; };</pre>			
Comments	In order to access the output it is necessary to enable the option in the exit tab for the controlled output <input type="checkbox"/> Arm On/Off Pulse confirmation <input checked="" type="checkbox"/> Logic Processor <input type="checkbox"/> Summary fail The activation time of the output is then overwritten by the logic module.			

Name of the function	geto(x)					
Destiny	Function that retrieves the logical state of the selected control panel output					
Syntax	y=geto(x) <input type="checkbox"/> x - logical variable to which the output state will be assigned 0 = disabled 1 = enable <input type="checkbox"/> y - number of the output state to be read 1-32					
An example from the logic wizard	Lp	A1	Funkcija	A2	Logika	
	1	O1	==	1	---	+ -
Script example	Information on the TPR panel about the activation of the O1 output <pre>int O1; int O1p; main () { while (1) { O1 = geto (1); if ((== 0 && O1p O1 == 1)) { HINT ("O1 was released"); }; O1p = O1; }; };</pre>					
Comments						

Name of the function	geti(x)
Destiny	Function that retrieves the logical state of the selected control panel zone
Syntax	Geti y = (x)

	<ul style="list-style-type: none"> • y - logical variable to which the input state will be assigned value 1 = violated 0 = intact • x - the number of the input the state of which should be read 1-48 			
An example from the logic wizard	No.	Result to	Function	A1
	1	O1	=	I1
Script example	<i>Rewriting the state of input I1 to output O1 (input tracking)</i> <pre>int I1; int O1; main () { while (1) { I1 = Geti (1); O1 = I1; Seto (1, O1); }; };</pre>			
Comments				

Name of the function	gett(x)				
Destiny	The function that takes the temperature value from the tsr-1 sensor				
Syntax	ghettos y = (x) <ul style="list-style-type: none"> • y - variable to which the temperature value from the sensor will be assigned • x - sensor number 1-4 				
An example from the logic wizard	No.	A1	Function	A2	Logic
	1	t1v	==	10	---
Script example	<i>Information on the TPR panel with a negative temperature measured by the temperature sensor No. 1</i> <pre>int t1v; main () { while (1) { T1V = ghettos (1); if (T1V <0) { HINT ("It is frost T =", t1v); } else { HINT ("Positive temperature"); }; }; WAIT (30,000); }; };</pre>				
Comments	The function returns only the total temperature in degrees Celsius If there is no sensor or failure, the function returns -999				

Name of the function	getenv()
Destinz	A function that retrieves the value of all system variables.
Syntax	getenv()

An example from the logic wizard	
Script example	<pre>int uzv; main () { while (1) { gbenv (); HINT ("power supply U [mV]", uzv); WAIT (1000); }; };</pre>
Comments	The function returns only the total temperature in degrees Celsius If there is no sensor or failure, the function returns -999

Name of the function	gettw(x)
Destiny	The function that takes the temperature value from the RHT-Aero wireless sensor (1-8)
Syntax	<pre>gettw y = (x)</pre> <ul style="list-style-type: none"> • y - variable to which the temperature value from the sensor will be assigned • x - sensor number 1-8
An example from the logic wizard	
Script example	<p><i>Information on the TPR panel with a negative temperature measured by the temperature sensor No. 1</i></p> <pre>int twv; main () { while (1) { TWV = gettw (1); if (TWV <0) { HINT ("There is frost T =", twv); } else { HINT ("Positive temperature"); }; }; WAIT (30,000); }; };</pre>
Comments	The function returns only the total temperature in degrees Celsius When a read error is found, the function returns -999

Name of the function	getthw()
Destiny	Function that takes the humidity value from the RHT-Aero wireless sensor (1-8)
Syntax	<pre>y=getthw(x)</pre> <ul style="list-style-type: none"> <input type="checkbox"/> y - variable to which the humidity value from the sensor will be assigned <input type="checkbox"/> x - sensor number 1-8
An example from the logic wizard	
Script example	<p><i>Information on the TPR panel with the humidity measured by the humidity sensor. No. 1</i></p> <pre>int thv;</pre>

	<pre> main () { while (1) { THV = getthw (1); if (THV> 70) { HINT ("Too high H =", thv); } else { HINT ("Humidity OK"); }; }; WAIT (30,000); }; }; </pre>
Comments	The function returns only the total humidity value in%. When a read error is found, the function returns 255.

Time relays.

Time-logic functions allow to execute programmed timers, triggering and reset of timers (blocks) identical to arguments in logic functions and results are written to outputs or markers.

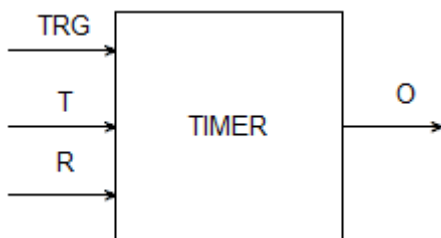

Symbol	Parameter	Description
TRG	Trigger	triggering signal
T	Time	time of the timer, function
R	Reset	reset signal
O	Output	function output
TIMER	Timer type	type of time / counter function

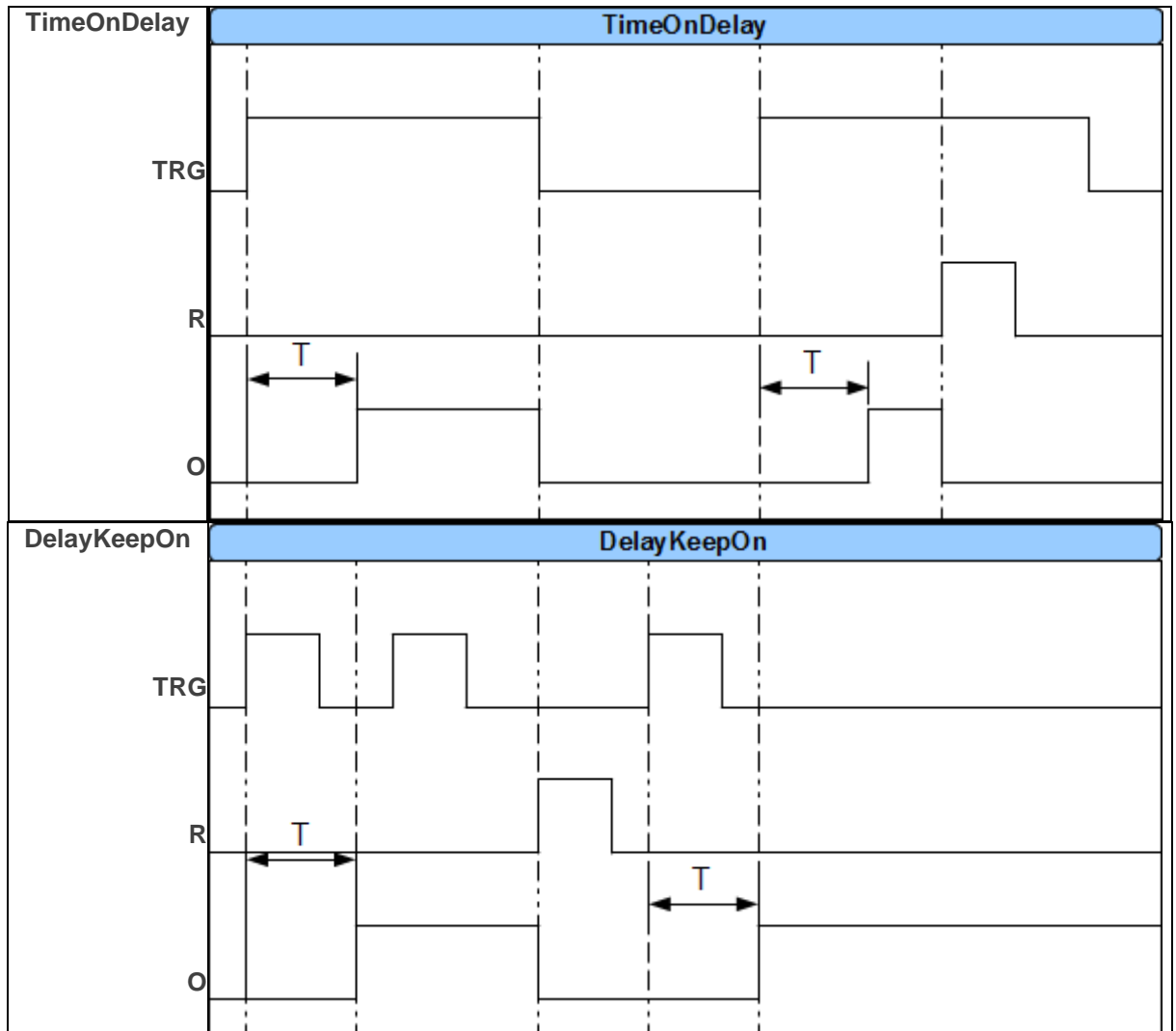

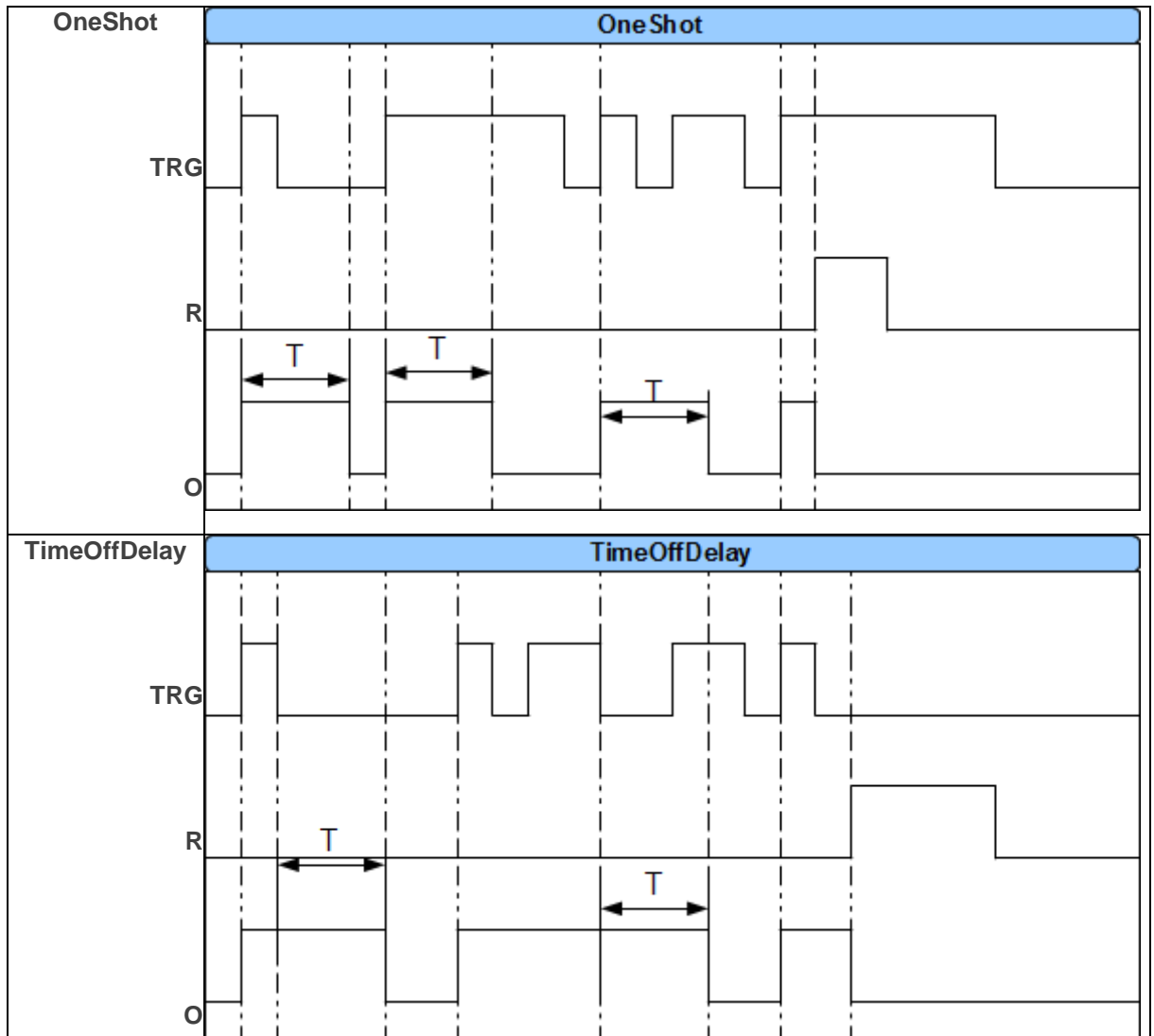

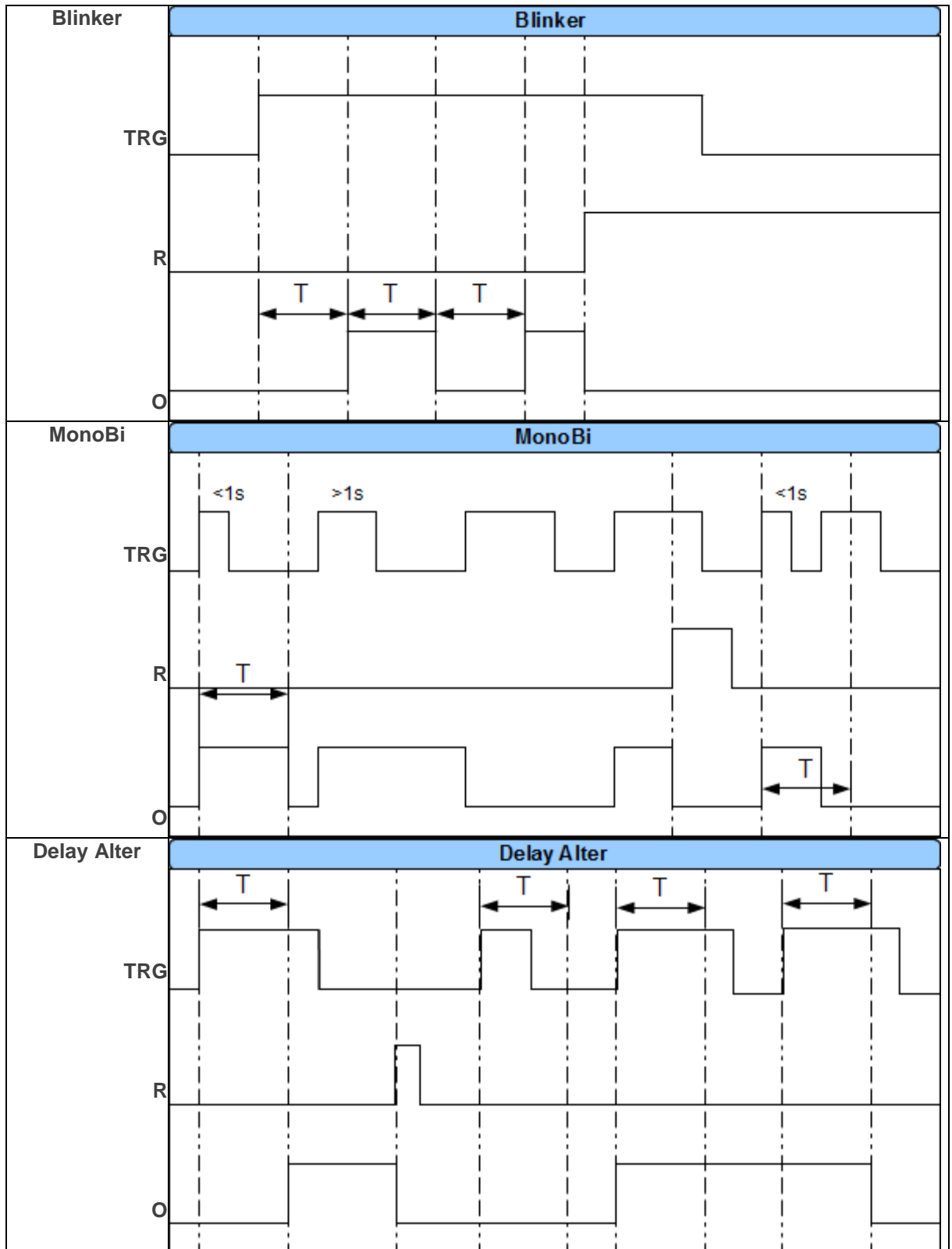

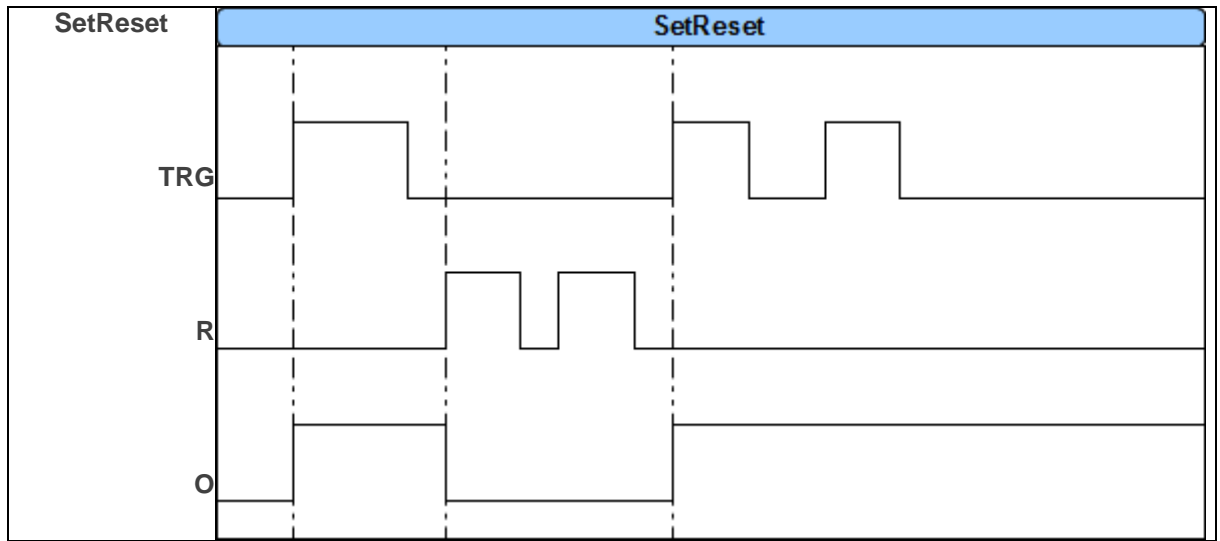

Starting values.

In order to avoid transients during the start of the LP script, you can set start values for the script based on the system resources intended for the Logic Processor.

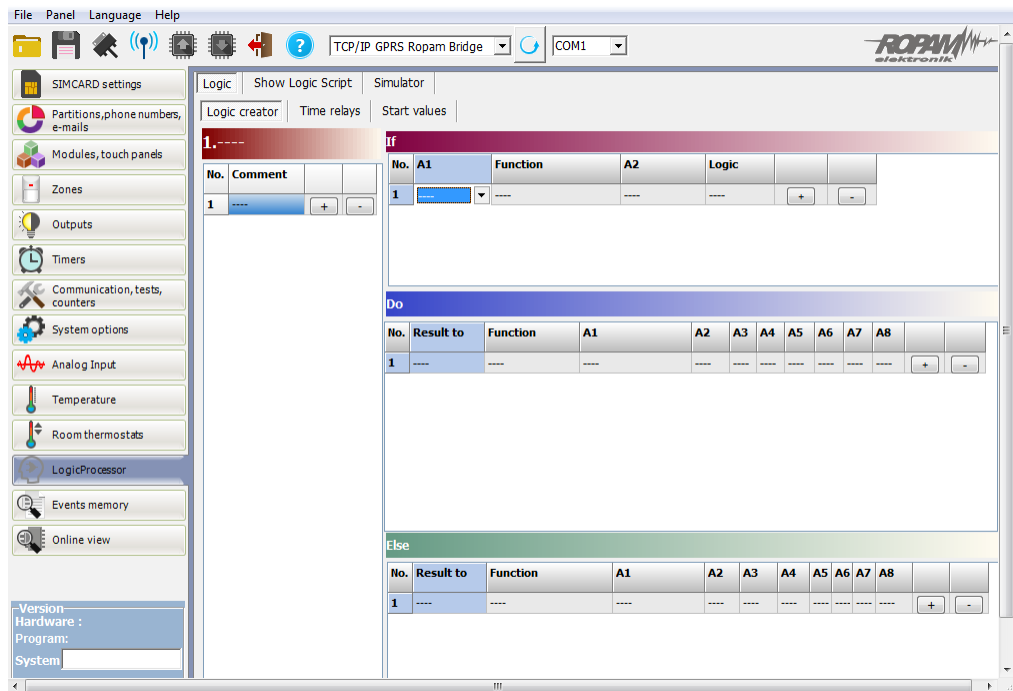

Preview of the script.

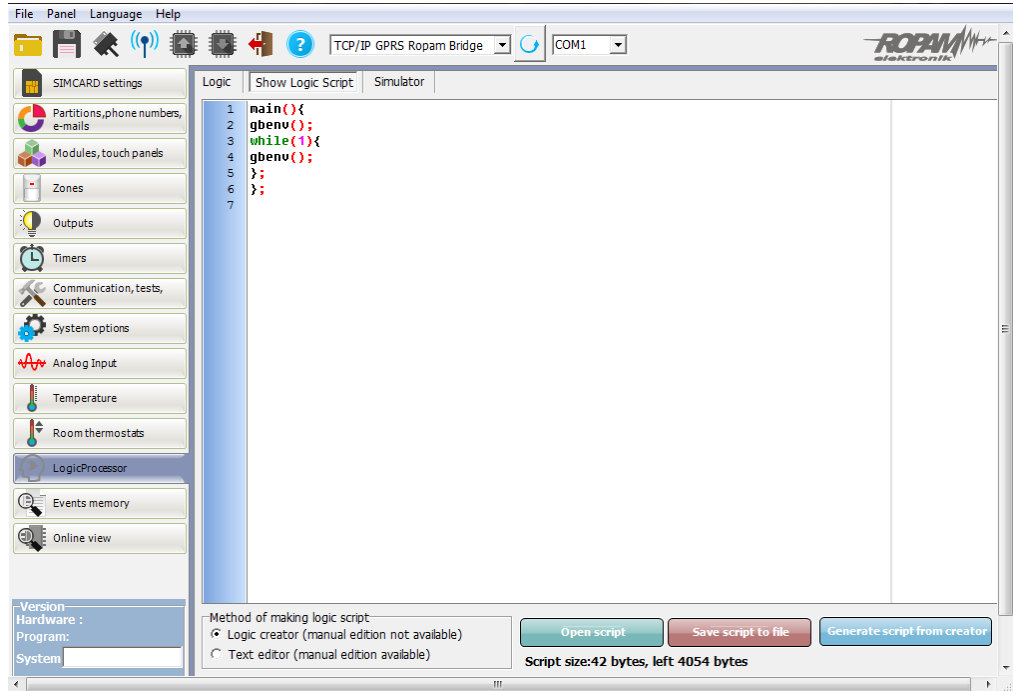

Simulator.

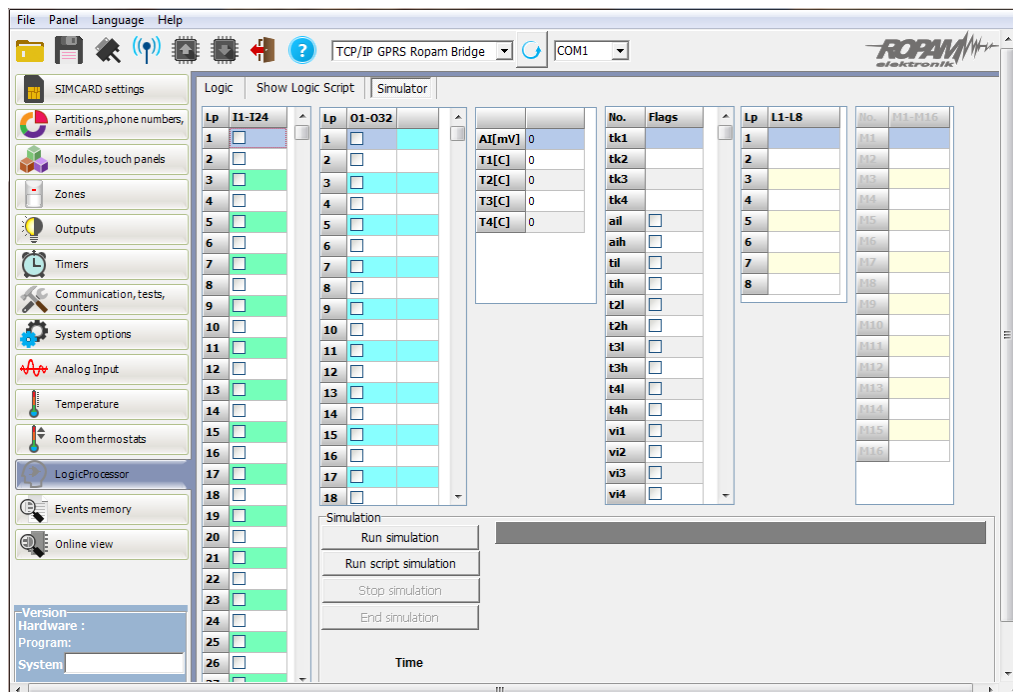

Application notes.

Data for the FTP server with technical data, application notes, firmware.
All in one place available through the FTP client.

server: ftp.ropam.com.pl
login: anonymous@ropam.com.pl
password: leave the field blank and click OK

Tab: Timers.

Settings of four independent timers allowing control of system arming, zones, control of outputs.

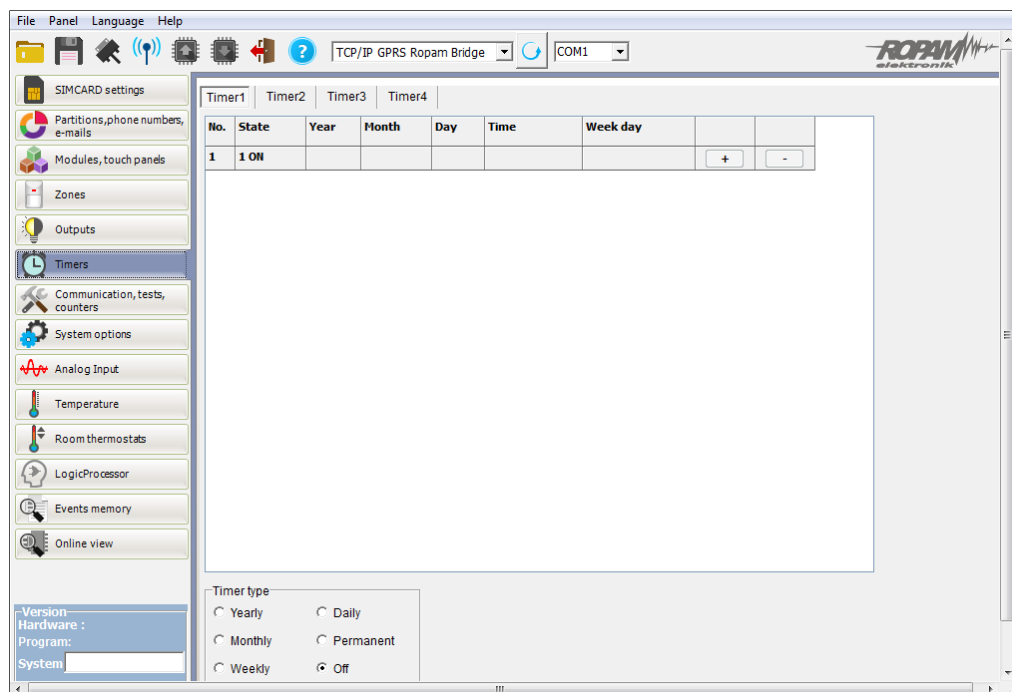

Tab: Communication, tests, counters.

Settings of parameters and methods of communication between the control panel and the user, the Internet network.

Configuring notifications in the event of a system failure.

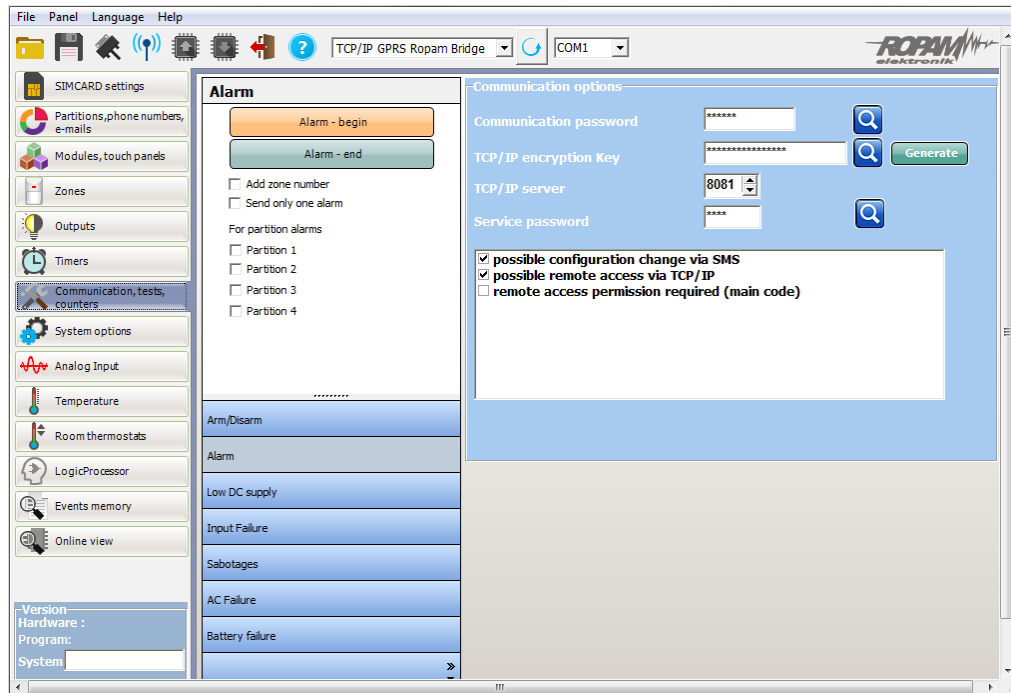

Tab: System options.

Settings of system options of the control panel (counters, times, transmission test, STAN messages, SMS control).

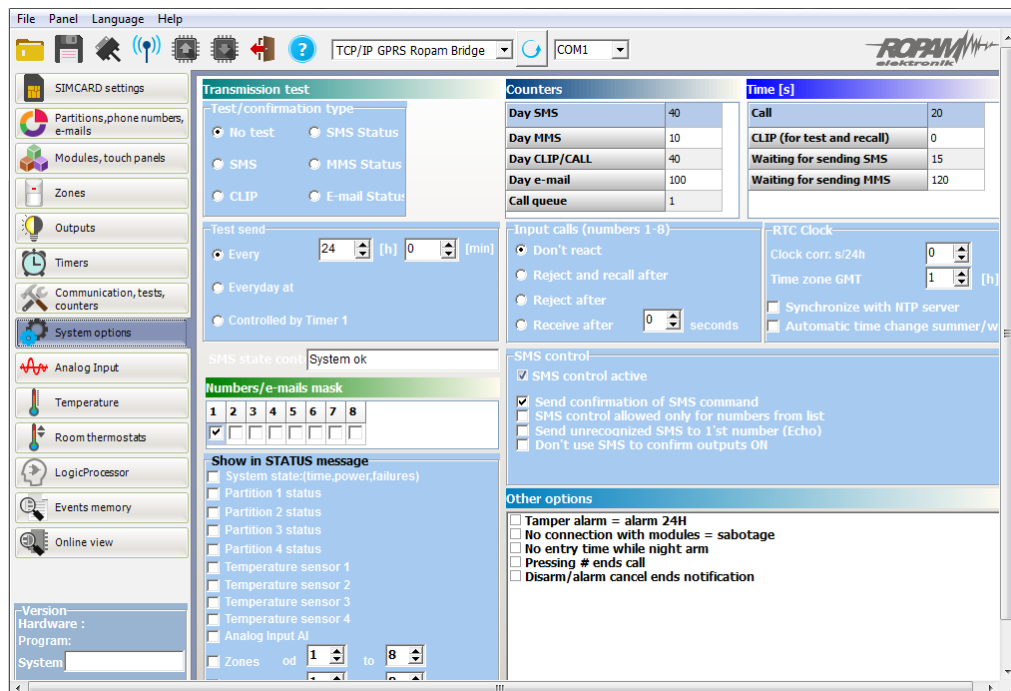

Tab: Analog input.

The tab allows you to configure the analog input.

PARAMETER - high voltage (H), low voltage (L),

VOLTAGE VALUE [mV] - one should give the value of threshold voltages in the range 0-10000, the minimum step 1.

CONTENT SMS - in the tab we enter the content of SMSes that will be sent on the event (reaching the set value). The maximum length of the SMS is 20 characters. It is not allowed to use special characters (eg Polish letters). **CALL** - selecting the option activates the action of calling (voice notification) at a given event.

COM. VSR - the column is used to configure the content of voice messages played when the input is violated in cooperation with the VSR-2 voice synthesizer.

Enter the characters corresponding to the numbers of the recorded voice messages and / or eavesdropping of the object:

- messages: 0,1,2,3,4,5,6,7,8,9, A, B, C, D, E, F

(maximum message time: 0-7 = 16s. 8-F = 8s.)

- audio module (microphone): m

It is possible to sum the content of the message by entering several characters (up to five characters) separated by a comma, messages will be played in the order in which they are listed in the tab. You can set independent messages for H and L.

NUMBERS 1 ÷ 8 - in the tab, select phone numbers for SMS and / or VOICE notification.

ADDITIONAL OPTIONS:

- "save every 30 minutes the temperature value to the event memory": selecting the option activates the option of recording voltage values to the event memory,

- "scale voltage value to physical quantities" - selecting this option will convert the measured value from [mV] to unit entered in the field "unit name" (eg V,% RH, kPa, etc.) and linearization by linear function $y = ax + b$

- "add measured value to the content of the SMS" - selecting this option will include the L or H threshold value (in mV or conversion) to the content of the SM downloaded from the "SMS content" fields

ANALOG INPUT SETTINGS:

HYSTERESIS [mV]: defines the required range of value changes when the measurement oscillates at the threshold point. Hysteresis zones are determined by the [H-hysteresis] and [L + hysteresis] formulas. Minimum value: 50, maximum 5000. Hysteresis creates deadband if the signal after crossing the threshold returns to the deadband zone, it will not change the output and will not generate a new transmission.

DELAY [ms]: required time for a stable voltage value to react to an H or L value being exceeded.

PHYSICAL VALUE FOR U = 0 [mV]: value for conversion of voltage to physical units, for typical sensors with 0-10V output: $0mV = Xmin, (y = ax)$.

NAME OF THE UNIT: enter the unit of the measured value, eg [V] - voltage,% RH - relative humidity, [kPa] - pressure, [° C] - temperature, etc..

WARNING:

- in case of sensors with voltage output (linear) in another voltage range, physical values should be calculated as for the linear function $y = ax + b$.

Tab: Temperature.

Parameter settings for temperature sensors in the system (4).

- temperature threshold settings,
- hysteresis,
- notifications

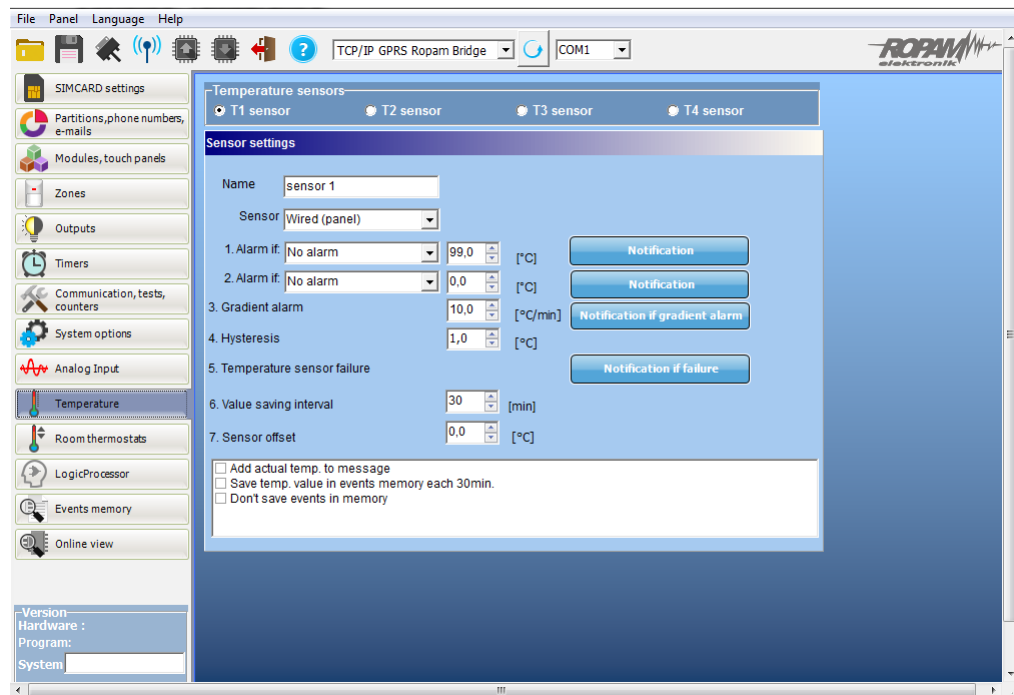

Tab: Room thermostats.

OptimGSM control panel offers thermostat functions based on the family of temperature sensors TSR-1 (x).

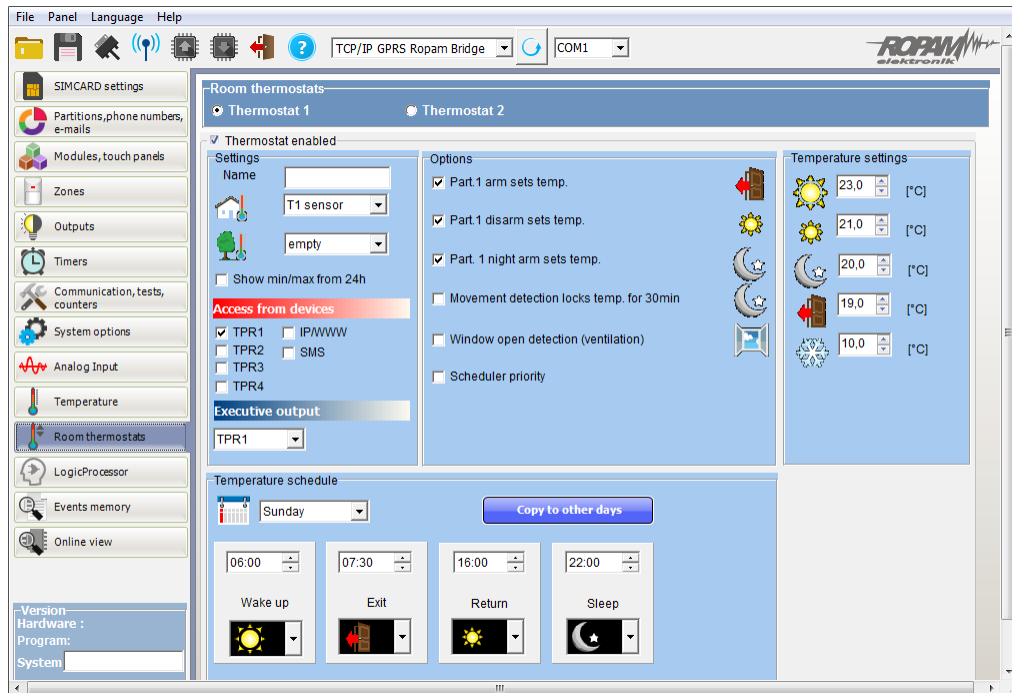

Tab: online.

PREVIEW OF ENTRANCE STATUS

The status of inputs is indicated by round indicators placed in the place of screw terminals of the module connectors.

The state in which the given input is located is determined by the color of the indicator:

- RED - entry violated
- YELLOW - entry sabotage
- GREEN - entry intact

COMMENTS

- ON-LINE preview requires an active connection via RS232TTL or a modem connection
- in ON-LINE mode, the module does not perform its standard functions, eg it does not send SMSes when inputs are violated, etc.

CHECK OUT STATUS

The option allows you to activate module outputs. For example, it is possible to test the siren without having to run the alarm procedure.

In order to trigger a given output (in accordance with the polarity set in the OUTPUT tab), the user should mark by clicking the mouse pointer on the white indicator located in the place of the screw terminals of the module connectors (in the place of the physical terminal of the given module output). After clicking the "√" icon will appear and it means the output is activated. Click again, uncheck the indicator and end the activation.

ENTER YOUR PIN CODE

Pressing the ENTER PIN code field will send the command module to enter the PIN code which is currently displayed in the SIM CARD PIN CODE field. The option allows testing the module with SIM cards of different operators without the need to change and save the configuration. The configuration saved to the MGSM module must have the option PIN CODE NEVER REQUIRED selected, in order to block the automatic entry of the PIN code by the module procedure.

COMMENTS:

- all activities related to the change of the SIM card, jumper settings, connections of modules and interfaces should be made after disconnecting the module's power supply and maintaining all available static protection.

SET TIME AND DATE

Pressing the SET TIME AND DATE box saves the time and date to the module from the PC. The correct time and date is required for sending the transmission test according to the clock and for the correct recording of events in the event log.

Time setting is also possible via the TIME configuration SMS, SMS format:
xxxx TIME year, month, day hour, minute where xxxx is the ACCESS CODE

SEND SMS TEST

The function allows you to send an SMS directly from the PARTNER GSM program in ON-LINE mode. The SMS content should be entered in the white field and press SEND. The SMS is sent to the first phone number entered in the NUMBERS tab.

or to send a test to any number enter in the field

xxxxxxxx; yyyyyyyyyyyyyy

where:

xxxxxxxx - telephone number

; - number separator from the content of the SMS

yyyyyyyyyy - content of sms (max 20 characters)

e.g. +48502636033; This is a test message

Netmonitor GSM (BTS).

The option opens a window in which data downloaded from the modem is refreshed. They provide advanced parameters of the GSM network.

The parameters of the current selected operator cell and the cube of the remaining available cells are given (x: {0-6})

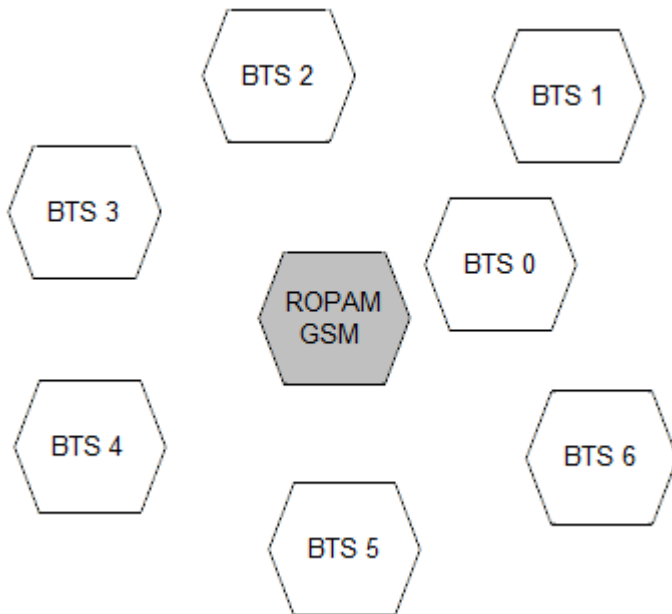

Active cell data contains information:

```
<cell>,"<arfcn>,<rxl>,<rxq>,<mcc>,<mnc>,<bsic>,<cellid>,<rla>,<txp>,<lac>,<TA>"
```

The remaining cell data contains information 1-6.

```
<cell>,"<arfcn>,<rxl>,<bsic>,[<cellid>,<mcc>,<mnc>,<lac>"...]
```

for example.

```
0, 0118, 28.9, 2960, 63, 766, 56.6, 609, 255
1, 0093, 22, 36, 6e2a, 260, 03, 6b09
2, 1004, 21.6, 6f0e, 260, 03, 6b09
3, 0112, 21, 37, d2fc, 260, 03, 6b09
4, 0101, 188, 6, 424, 60, 63, 6b09
5, 011, 13.39, d339, 260, 03, 6bc
6, 0102, 19, 38, d9c8, 260, 03, 6b09
```

Legend:

<cell>	0	the serving cell
	1-6	the index of the neighboring cell
<arfcn>		absolute radio frequency channel number
<rxl>		receive level
<rxq>		receive quality
<mcc>		mobile country code
<mnc>		mobile network code
<bsic>		base station identity code
<cellid>		cell id
<lac>		location area code
<rla>		receive level access minimum
<txp>		transmit power maximum CCCH
<TA>		Timing Advance

Example of data usage:

1. GSM network identification:

mobile country code: PL = 260
mobile network code for Poland:
260 01 Plus GSM 1
260 02 ERA PL 2 Heyah
260 03 Orange PL 1
260 06 Play Mobile 1

2. Identification of cellid (CID), LAC

Finding CID: enter the hex cellid number (with h at the end, search type, exact) in:
<http://btsearch.pl/index.php>

We filter the results by the operator code and get the BTS data.

Tab: events.

The real-time clock used in the device allows recording in the memory of events of the module violation of inputs, functions, tests, etc. The memory contains 10,000 events that have occurred recently, the memory is overwritten and the oldest information is deleted in a chronological manner. The clock is battery-operated (up to 3 years) in the event of a complete power failure.

MMS from the exchange are sent via GPRS and use the MMS stack. For confirmation of successful transmission or error, events are logged.

MMS error code	Description
	MMS sent (multimedia message delivered to the MMSC center).
10	There is no possibility of taking a picture (3x) by FGR-4: no video signal, no communication with FGR-4.
171	MMS task occupied, e.g. sending the previous MMS.
172	MMS data size exceeded.
173	MMS sending operation time exceeded (information from GSM modem).
174	Incorrect MMS recipient.
175	The memory for the recipient's address is full.
176	The recipient was not found.
177	Connection to the GSM network failed.
178	Error reading MMS.
179	MMS type error: MMS push.
180	GPRS not available.
181	TCP / IP task occupied by another thread.
182	MMS memory is full.
183	The box is empty.
184	Error writing MMS to memory.
185	Tasks involved in the preparation of MMS.
186	Task now has no access to MMS editing.
187	Empty data buffer.
188	File not found.
189	MMS reception error.
190	Error reading MMS from the mailbox.
191	MMS identification error.
193	Unknown MMS error.
255	MMS sending time is over 120 s. (Information from the control panel task).

5. System operation.

Applications that allow the OptimaGSM system to be operated via SMS, DTMF or TCP / IP.

Basic SMS commands.

ARRANGEMENT:

The control of armed mode by SMS consists in sending an SMS about the form, access to functions and zones, determining the authorization of the given code.

Command	Description	Example	Reply
#### ARM #### ARM 1,2,3,4	Arming the system (supervision) (full or indicated zones)	5555 ARM 5555 ARM 1,2	Armed system. Arming error, check the code permission to zones.
#### ARM NIGHT #### ARM NIGHT 1,2,3,4	Arming (supervision) of the night system (all or selected zones)	5555 ARM NIGHT 5555 ARM NIGHT 1,2	Night vigil included. Arming error, check the code permission to zones.
#### DISARM	Disarming the system (supervision) (full or night, all or selected zones)	5555 DISARM 5555 DISARM 1,2,	The system disarmed. Disarm, disarm code to zones.

The armed mode control via SMSs is interpreted by the system in the same way as control from the touch panel.

CONTROL OF OUTPUTS:

Controlling the outputs via SMS consists in sending an SMS with a specific content, the control command may require an access code or not (service). The flexible software of the module allows that: **the content of SMSs controlling outputs can have any content, eg pump on, pump off.** The exact parameters of the outputs and their intended use are determined by the installer. The control syntax using the factory control commands is shown below:

Command	Description	Example	Reply
#### onx	Turning on output x, where x is the output number	5555 lighton	Exit attached (x) 'SMS On content' where: x = the number of the output in the system, 'SMS content on / off' = SMS content set to control the given output
#### offx	Turning off output x, where x is the output number	5555 lightoff	Output disabled (x) 'SMS text off'

Command	Description	Example	Reply
			where: x = the number of the output in the system, 'SMS content on / off' = SMS content set to control the given output

If touch panels are installed in the system, the relay output can also be remotely controlled via SMS commands:

Command	Description	Example
#### ontpx	Turn on relay output on the TP panel, where X = panel number (address, service)	5555 ontp1
#### offtpx	Turn off relay output in the TP panel, where X = panel number (address, service)	5555 offtp1

If a radio controller is installed in the system, the control of two relay outputs is additionally available. Controlling via SMS consists in sending an SMS about the form:

Command (####= access code)	Description	Example
#### onrx	Turn on relay x , where x (1,2,3,4) is the RF-4 relay / output number	1212 onr1
#### offrx	Turning off relay x , where x (1,2,3,4) is the number of RF-4 relay / output	1212 offr1

REMOTE CONFIGURATION OF SELECTED FUNCTIONS:

Access to the remote control can be blocked in the control panel settings (service), the selected commands are only available for the main code in the system or the service code.

Parameter	Description	Example	Reply
#### code zzzz	Change of the SMS access code zzzz = new access code	5555 code 0987	Configuration changed
#### time rr, mm, dd, gg, mi	Setting or changing the date and time (yy, mm, dd, hh, mi = year, month, day, hour, minute)	5555 time 17, 01, 01, 12, 05	Time set on 17/01/01 12:05
#### restart	Restart of control panel	1234 restart	

Parameter	Description	Example	Reply
#### downloading x	Remote activation / deactivation of the modem connection function X = 1 function included x = 0 function disabled	5555 downloading 1	Configuration changed
##### replysms x	Remote activation / deactivation of the confirmation return function for SMS commands X = 1 function included x = 0 function disabled	5555 replysms 1	Configuration changed
##### echo x	Remote on / off the function of sending undetectable SMSes from the ECHO network, e.g. passwords to the www account, information from the network X = 1 function included x = 0 function disabled	5555 echo 1	Configuration changed
#### setapn	GPRS access configuration: APN user password.	123B setapn internet internet internet	Syntax: [service code or main] setapn apn user password (blank skip)

Basic DTMF commands.

CONNECTION / DISABLEMENT OF PARTITION ZONE:

- arming / disarming the system via the DTMF code:

syntax: choose from the DTMF phone keypad:

[code] # 1 arms all zones to which the given code has access

[code] # 0 disarms all zones to which the code has access

Example:

main code 5555 # 1 - will arm all zones 1-4

CONTROL OF RYGLES (opening):

The VAR-1U module enables the remote opening of the bolt using the DTMF code during the ongoing voice connection between the user and the OptimaGSM system.

Przekierowanie rozmowy po [s] - funkcja umożliwiająca odtworzenie komunikatu z modułu VSR-1 zamontowanego w bramce domofonu VAR-1U (zalecamy by czas przekierowania nie był krótszy niż czas trwania komunikatu w module VSR-1).

To use the option of opening the bolt using the DTMF code, enter the code (1-4 digits) in the field, and the DTMF code is confirmed by pressing "*"

Dialing configuration window and DTMF opening code:

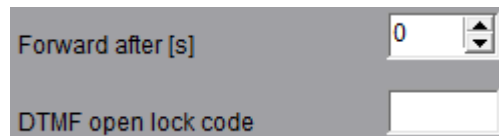

The image shows a configuration window with two fields. The first field is labeled 'Forward after [s]' and contains the value '0'. The second field is labeled 'DTMF open lock code' and is currently empty.

RopamDroid application.

In order for the RopamDroid application to function properly with the OptimaGSM system you should:

- use the RopamDroid version from 1.8 and higher,
- set:

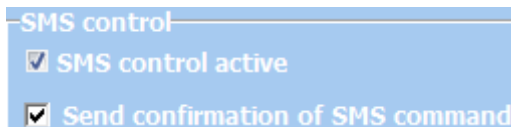
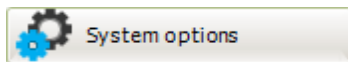

- set the SMS password in the RopamDroid application (max 4 characters), convergent with the user's password in the OptimaGSM system.

RopamOptima application.

The RopamOptima application is used to operate the OptimaGSM system. The connection is made via the TCP / IP protocol.

After connecting with the control panel, you can perform the following operations:

- view of the control panel status,
- view of zone states,
- view of output states,
- control of outputs (remote switching on of lights, opening of gates, control of blinds, etc.),
- partitioning,
- disarming zones,
- view of current system failures,
- system events preview,
- downloading and displaying photos from IP cameras captured by AP-IP (RTSP),
- a public and static IP address is not required in RopamBridge mode.

Requirements:

OptimaGSM control panel v2.3 or higher.
Communication module AP-IP version v1.4 or higher.

Phone or tablet with Android, Apple iOS, Windows10 Mobile.

Launching

After installation, the RopamOptima application should be started by tapping on the application icon.



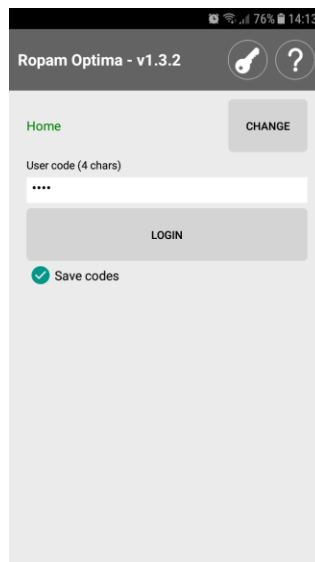

After starting the user, the login screen appears.

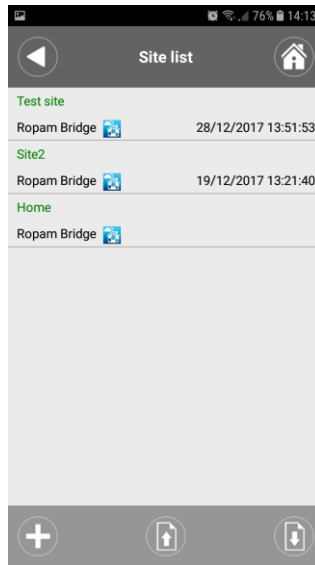

For correct login it is necessary to define and select the object with which we want to connect (there may be many of them).

We touch the "Change" button. A screen with a list of objects will appear:



Pressing the button  opens the screen to create a new object.

Example configuration without RopamBridge (logging in to a local network or using a fixed IP, external domain / IP address).

The values entered in the fields are checked and in the case when the application determines that the entered value is incorrect, the text in the field will be highlighted in red.

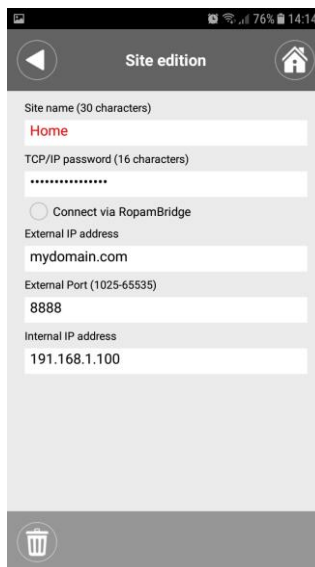

Configuration

An exemplary configuration using a connection via RopamBridge.

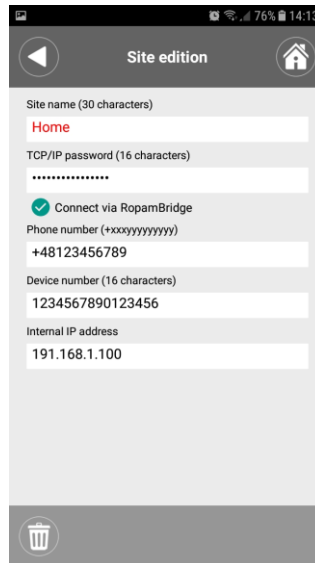

Reading the data needed to configure the application is possible from the menu level in the TPR-1 touch panel.
(User settings -> Internet module -> Show network status)

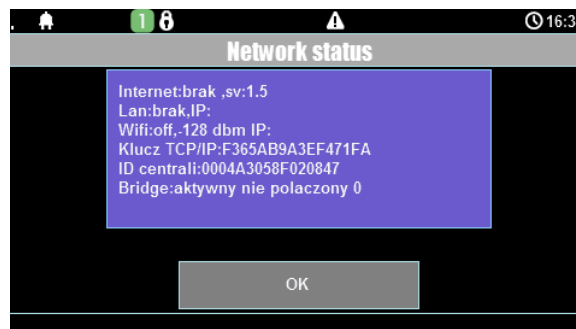

After entering the mandatory data and exiting the screen, the data will be saved in the application and the object will appear in the list of objects.

The data of the previously entered object can be edited by performing a left-shift "swipe-left" on the object or by pressing (tap) and longer holding the finger on the object. Then the object window appears with the previously entered data.

Settings for objects can be transferred to another device using settings export / import.

When in the list of objects we click briefly on a single object, we perform the operation of selecting the object and then we go to the login screen, where the information about the selected object appears.



Exporting object settings to a file. The file can be protected with a 16-character password.



Import of object settings.

When in the list of objects we click briefly on a single object, we perform the operation of selecting the object and then we go to the login screen, where the information about the selected object appears.

After entering the user code, you can log in by pressing the "Login" button.

The user code is a four-character code for the OptimaGSM central with the permission to control via SMS / www.

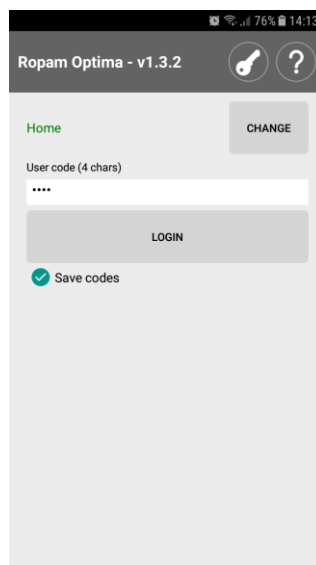

System demo

The Ropam Elektronik company allows you to connect to the "Demo" object using the RopamOptima application, which allows you to easily find out about the possibilities of the system and check its functionality.

To do this, the program must be configured as follows:

TCP / IP password: 1234567890123456

External IP address: 91.222.117.246

External port: 8888

6. SMTP settings for GPRS and IP.

The following settings apply to the IP communication channel via GPRS and the AP-IP module. The description also contains information on error codes that inform about unsuccessful operations when transmitting data via an IP channel.

If the system requires sending e-mails to individual users (1-8), please enter their addresses in the tab:

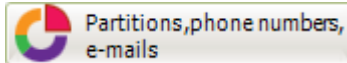

Phone numbers, e-mail addresses			
No.	Name	Phone No.	E-mail address
1			
2			
3			
4			
5			
6			
7			
8			

Sample e-mail accounts.

OptimaGSM does not support SSL and TLS authorization for GPRS communication!

Examples of SMTP accounts:

Server	Incoming mail server (POP3)	Outgoing mail server (SMTP)	Account name	SMTP server port number	Secure connection (SSL)
wp.pl	pop3.wp.pl	smtp.wp.pl	nazwa_konta	587	No
onet.pl	pop3.poczta.onet.pl	smtp.poczta.onet.pl	nazwa_konta@onet.pl	587	No
interia.pl	poczta.interia.pl	poczta.interia.pl	nazwa_konta	587	No
interia.eu	poczta.interia.eu	poczta.interia.eu	nazwa_konta@interia.eu	587	No

It is necessary for accounts configured in the system to be ACTIVE! That is to say: there should be standard traffic on them (receiving and sending messages), otherwise they will be deleted by the service provider (see regulations on the use of an e-mail account).

Set up an e-mail account, OptimaGSM Manager.

Below is an example configuration of an e-mail account for the OptimaGSM system and sending e-mail notifications through the AP-IP module.

SMTP e-mail settings(req. for e-mail sending)	
Parameter	Status
SMTP Server	mail.ropam.com.pl
SMTP Port	587
SMTP User	test@ropam.com.pl
SMTP Password	#####
Sender address	test@ropam.com.pl
Sender name	RopamTestAIP
SMS if sending error	<input checked="" type="checkbox"/>
<input checked="" type="checkbox"/> Send e-mail via AP-IP	
Security connection	
<input checked="" type="radio"/> without encryption <input type="radio"/> TLS <input type="radio"/> STARTTLS	

Below is an example configuration of an e-mail account for the OptimaGSM system and sending e-mail notifications via GPRS.

SMTP e-mail settings(req. for e-mail sending)	
Parameter	Status
SMTP Server	mail.ropam.com.pl
SMTP Port	587
SMTP User	test@ropam.com.pl
SMTP Password	#####
Sender address	test@ropam.com.pl
Sender name	RopamTestAIP
SMS if sending error	<input checked="" type="checkbox"/>
<input type="checkbox"/> Send e-mail via AP-IP	
Security connection	
<input type="radio"/> without encryption <input type="radio"/> TLS <input type="radio"/> STARTTLS	

Prioritizing sending messages.

To give priority to sending e-mails using the preferred access channel (GPRS or IP), select the appropriate settings in the tab:

Modules -> AP-IP and then select the desired option.

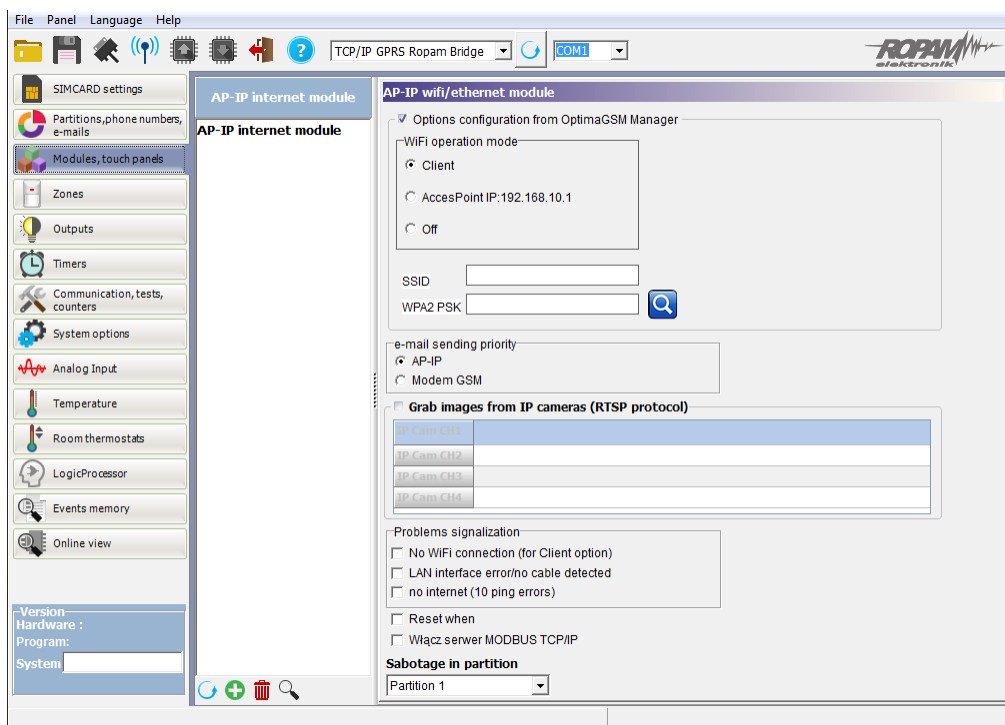

Email notifications about events.

The OptimaGSM system has the ability to send e-mails with different types of events in the system:

- entry violations
- change in the status of outputs
- motion detection by PAL cameras (FGR-4 module required)

Configuration of sending an e-mail about the entry violation:

The screenshot displays the ROPAM Elektronik software interface for configuring email notifications. The main workspace is divided into two tabs: 'Zone attribute' and 'Notification'. The 'Notification' tab is active, showing a table for configuring email notifications for 8 zones. The table has columns for zones 1 through 8 and rows for different notification types. The 'E-mail to:' row is checked for zone 1. Below the table, there are fields for 'SMS/E-mail content', 'TCP/IP code', and 'VSR-2 messages'. The 'Add STATUS' checkbox is checked.

Tel/e-mail	1	2	3	4	5	6	7	8
Sms to:	<input type="checkbox"/>	<input type="checkbox"/>	<input type="checkbox"/>	<input type="checkbox"/>	<input type="checkbox"/>	<input type="checkbox"/>	<input type="checkbox"/>	<input type="checkbox"/>
Call to:	<input type="checkbox"/>	<input type="checkbox"/>	<input type="checkbox"/>	<input type="checkbox"/>	<input type="checkbox"/>	<input type="checkbox"/>	<input type="checkbox"/>	<input type="checkbox"/>
MMS to:	<input type="checkbox"/>	<input type="checkbox"/>	<input type="checkbox"/>	<input type="checkbox"/>	<input type="checkbox"/>	<input type="checkbox"/>	<input type="checkbox"/>	<input type="checkbox"/>
MMS to e-mail	<input type="checkbox"/>	<input type="checkbox"/>	<input type="checkbox"/>	<input type="checkbox"/>	<input type="checkbox"/>	<input type="checkbox"/>	<input type="checkbox"/>	<input type="checkbox"/>
E-mail to:	<input checked="" type="checkbox"/>	<input type="checkbox"/>	<input type="checkbox"/>	<input type="checkbox"/>	<input type="checkbox"/>	<input type="checkbox"/>	<input type="checkbox"/>	<input type="checkbox"/>

Below the table, the 'SMS/E-mail content' section includes the following fields:

- TCP/IP code
- VSR-2 messages
- Add pict. seq. to MMS/e-mail:
- FLASH type SMS:
- Add STATUS:

Configuration of sending an e-mail about the change of the output status and detection of traffic:

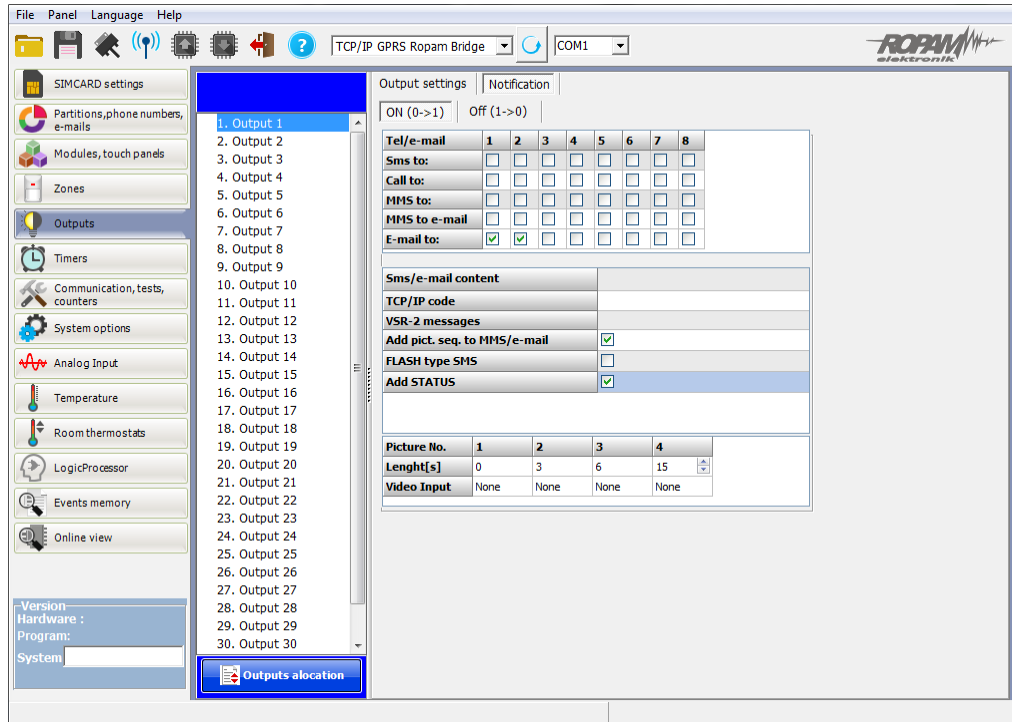

Errors - sending an e-mail.

Modem errors for sending an e-mail transmission (SMTP -> GPRS).

- 61 - GSM network error,
- 62 - DNS server error (GSM operator),
- 63 - TCP SMTP (GPRS) connection error,
- 64 - exceeding the SMTP server response time (SMTP timeout),
- 65 - no authorization, SMTP server response,
- 67 - authorization error, SMTP user or incorrect password,
- 68 - transmission error, incorrect e-mail data,
- 100 - exceeding the time of sending an e-mail (timeout 30s).

The e-mail transmission errors for AP-IP are saved in the IP module log -> LuCi).

To view the LuCi system log, log in to the AP-IP module via a webserver. After logging in to the



webserver, in the "Settings" tab, select the icon:

After the login screen appears:

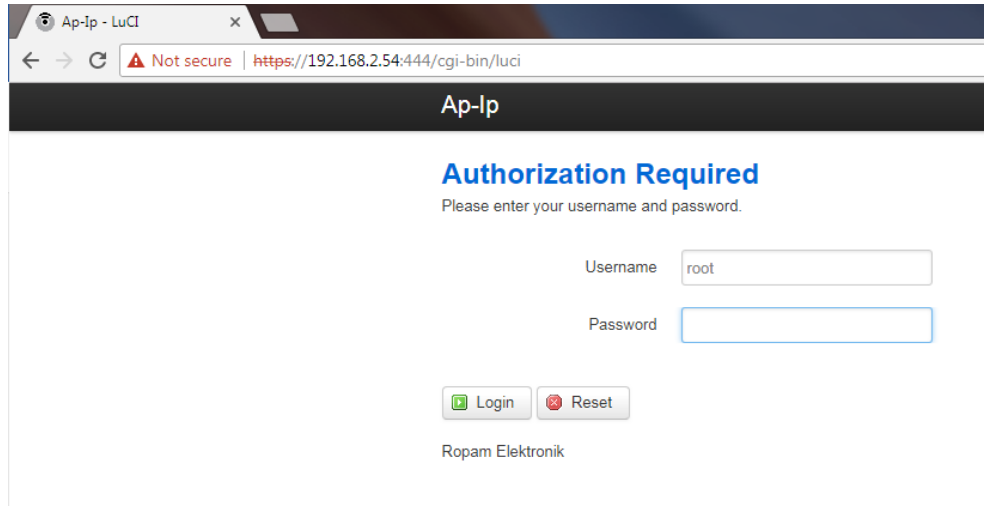

go to the Status -> System Log tab and view the history of errors that require intervention.

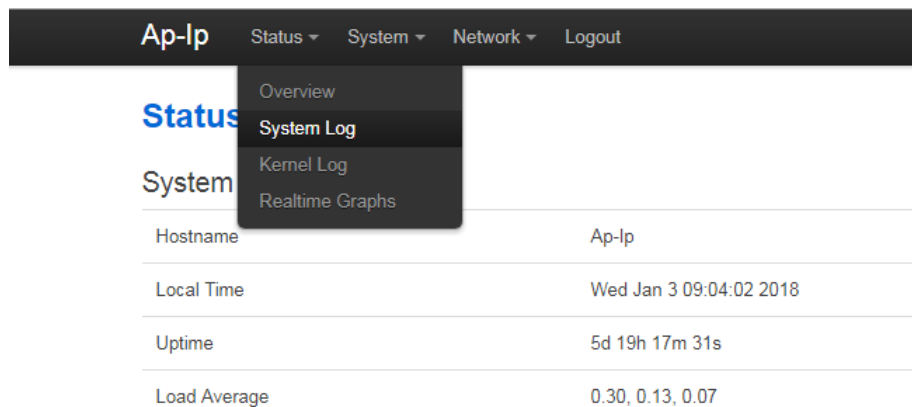

7. System maintenance.

The control panel does not require special maintenance. During periodic technical inspections, it is necessary to check the condition of screw joints, emergency power supply status, clean the PCB with compressed air. The system should be periodically tested for proper operation and communication.

8. Technical parameters.

Parameter	Value
OptimaGSM power supply	U = 9V ÷ 14V / DC min / max @ 1.5A min. (for work as a switchboard PSR-ECO-5012-RS required power supply)
OptimaGSM-PS power supply	U = 16V÷20V/AC min/max @ 30VA min. U = 20V÷28V/DC min/max @ 0,7A min.
OptimaGSM-PS power supply output voltage	Un= 13,8V/DC (+/- 2%) U=9,5V-13,8V/DC**.
OptimaGSM-PS power supply (current efficiency) *	20W (1,5A)
DC power failure signaling	U<11V
Load capacity of controlled outputs O1, O2 , and power supply AUX, KBD	In = 1.0A (continuous) Ipeak = 1.3A (instantaneous)
Short-circuit protection and thermal outputs O1, O2, AUX, KBD	Ilim = 1.0A ÷ 1.7A, Tj, Tc = 125 ° C (condition: limit of short-circuit current or output overload)
Load control for O1, O2 outputs	2KΩ max. line impedance
Load capacity of O3-O8 outputs	100mA @ 30Vdc max. (no short-circuit protection)
Power consumption by control panel systems (without exits)	40mA/50mA/300mA min/mid/max
Battery cooperating with OptimaGSM-PS	12V, 1,2Ah - 12Ah (VRL/SLA)
Battery charging current OptimaGSM-PS	Ibat= 0,3A max.
Output protection + BAT- OptimaGSM-PS	undervoltage: Ubat <10,0V (+/- 5%) Reverse polarity protection and short circuit protection: 1.6A PTC fuse (reversible)
Modem GSM	SIM900 (Quad-Band, GPRS class 10, CSD)
GSM modem frequency	850/ 900/ 1800/ 1900 MHz (switched automatically)
The type of data transmission	SMS, VOICE, MMS, GPRS

Parameter	Value
Signal audio AUDIO IN, AUDIO OUT (złącze VSR))	2 Vrms.
Binary inputs (Programmable)	NO, NC, EOL, 2EOL/NC, 2EOL/NO= hi-Z/~30Ω, ~30Ω/hi-Z, hi-Z/2k2, 1k1/2k2, 2k2/1k1 Line impedance for a given type: no violation / violation
Inputs of temp sensors	T1-T4 (Data), GND, +VT (3,3V)
Analog input (Programmable)	Uin= 0-10V/DC (max.) (impedance Z = 30KΩ, resolution 10mV, accuracy 1% of the whole range)
System communication	EIA-485 - RopamNET system bus RS323TTL - connection to the service computer (communication, upgrade)
Working conditions	environmental class: II t -10 ° C ... + 55 ° C RH: 20% ... 90%, no condensation
Connectors	AWG:24-12, separable
Dimensions: OptimaGSM/ OptimaGSM-PS OptimaGSM-xx-D9M	156x 88 x 25 [- / + 1] [mm] 159.5 x 90 x 58 [- / + 1] [mm] housing DIN 9M
Weight: OptimaGSM OptimaGSM-PS OptimaGSM-D9M OptimaGSM-PS-D9M	125g net 145g net 265g net 285g net

9. Version history.

OptimaGSM	Date	Description
1.4	2014.04.07	<ul style="list-style-type: none"> - fixes: temperature conversion for reading > 60 degrees, - change: arming with the help of RopamDroid / SMS takes place without time to exit,
1.5		<ul style="list-style-type: none"> * new features: <ul style="list-style-type: none"> - Supports 1-VAR Kenwei, - APm-Aero support in v.OptimaGSM version (16 detectors), - an independent zone selection option for alarm notification or arming / disarming, - option of resetting the control panel by means of a jumper on connector X3 (see description), * corrections: <ul style="list-style-type: none"> - fixed completion of voice notification queues when the control panel is unarmed, - improved control over the outputs of IO / IOE-IQPLC modules when the control panel is online,
1.6	2015.05.05	<ul style="list-style-type: none"> * new features: <ul style="list-style-type: none"> - SMS command: [code] of the input - it displays the name of the input along with its status by text, the range of displayed inputs is the same as in STATUS, the message can be divided into max. 2 SMSes, - SMS command: [code] onr1, onr2, onr3, onr4, on5 and offr1, offr2, offr3, offr4 to control RF-4 outputs, * corrections: <ul style="list-style-type: none"> - SMS command: [code] get file_name - download the photo from the SD card in FGR4, - SMS command: [code] folder - downloading the contents of the SD card catalog (file names), - SMS command: [code] photo 1,2,3,4 - taking a photo from selected cameras in FGR4, - problem with resetting alarm inputs in MONOstable mode, - operation of the 'delayed', 'conditionally delayed' inputs in the night watch, - operation of the '24h' type inputs, - parallel control of outputs, e.g. SMS, LogicProcessor, TP, - erroneous operation of the option "do not confirm with SMS by switching outputs", confirmation was not turned off,
1.7	2015.07.01	<ul style="list-style-type: none"> * new features: <ul style="list-style-type: none"> - possibility of remote programming via TCP / IP (GPRS), required by OptimaGSM manager 1.4, - SMS command: [code] connect or [code] connect IP: port - command for establishing connection via RopamBridge server or another server (service computer with fixed IP and open port), option to choose in OptimaGSM Manager 1.4 program

OptimaGSM	Date	Description
		* corrections: - polarization of the NC output for EXP-O8x (there was only NO polarization), - WAIT (0) function in LogicProcessor (control panel reset required) - SMS command: [code] offtpx, - online mode, sending a test SMS (wrong message about failure),
1.8	2015.07.30	- connection flag added from IAS in LP "ctr" 1 - when active connection 0 - no active connection - added LOCK () function in the LP, its calling opens the lock in the intercom - added ARMF (X) function in LP full zone arming X - zone number 1-4 - added ARMN (X) function in LP night setting of zone X - zone number 1-4 - DISARM (X) function added in LP full zone X zone arming - zone number 1-4 - added LOCK () function in the LP, its call opens with the KENWEI door intercom
1.9	2015.11.17	- added ability to add / delete telephone numbers by the main code (until now only the installer) - sms added [xxxx] heating y zz.z where y - number of thermostat 1 or 2 zz.z - set temperature in st C 7-45stC
2.0		- operation of two-way pilots by AP-AERO - adding information about the service mode in RopamDroid - operation of wireless outputs in the IO-AERO module of the control panel output (16-32) - inserted: the INFO type input option does not generate required events OM1.7 - the option to disable recording of temperature events to the event log has been added - possibility to choose zones that are displayed in sms / email STATUS
2.1	2016.03.21	- an offset temperature sensor has been added, required OMv1.8 - added: internet setting command: [xxxx] setapn aaaaaa bbbbbb ccccc where: aaaaaa -APN bbbbbb -cccc-password eg 123B setapn internet - added: apip activation to work with apk sms application: xxxx deviceup yy yy-time no time permanently 0- off - added: option: calendar priority in the room thermostat (forces during the time changeover from manual to calendar mode) required OMv1.8
2.2	2016.07.12	- the option of sending mms to e-mail addresses has been added (OMv1.9 required)

OptimaGSM	Date	Description
		<ul style="list-style-type: none"> - added functions for temperature and humidity reading of wireless sensors Aero in LP gettw (1-8) (temperature) and gethw (1-8) (humidity) example: th1 = gethw (1); fills moisture from sensor 1 aero to variable th1 when sensor read error, it returns -999 for temp and 255 for humidity - protection against too frequent switching of the room thermostat's output has been added when the temperature differs from the set lower than 1stC (switching lock for 30min) - an e-mail test button has been added via modem (sends to the 1st e-mail address)
2.3	2016.08.11	- MODBUS TCP support (activation of AP-IP tab required in OM v2.0)
2.4	2016.09.19	<ul style="list-style-type: none"> - support for arming / disarming the system via the DTMF code: syntax: choose from the DTMF phone keypad: [code] # 1 arms all zones to which the given code has access [code] # 0 disarms all zones to which the code has access Example: main code 5555 # 1 - will arm all zones 1-4
2.5	2016.11.02	<ul style="list-style-type: none"> - increased maximum length of variable in LP to 5 characters, in the case of long variable declaration a syntax error is reported - an option to refresh the software version of the connected modules is added (press the blue circle icon with an arrow in the OM) - VSR-2 messaging system armed / disarmed by VHF control via DTMF [code] # 1 arms, [code] # 0 disarms
2.6	2016.12.29	<ul style="list-style-type: none"> - improved Toffdelay time relay - improvement of the stability of the RopamNET bus

10. Information.

The Ropam Elektronik company is the sole owner of copyrights to the materials contained in the documentation, catalog and website, in particular for photos, descriptions, translations, graphic form, presentation.

Any copying of information or technical materials found in catalogs, on websites or otherwise provided by Ropam Elektronik requires written permission.

Ropam Elektronik is not liable for mistakes made during printing and errors in technical documentation.

All names, trademarks and trade names used in this manual and materials are the property of the respective entities and have been used only for information and identification purposes.

PRODUCENT:

Ropam Elektronik

Polanka 301
32-400 Myślenice, Polska

Tel. +48 12 272 39 71

Fax +48 12 379 34 10

<https://www.ropam.com.pl/en>